

THIS DRAWING IS UNPUBLISHED. RELEASED FOR PUBLICATION. COPYRIGHT BY TYCO ELECTRONICS CORPORATION. ALL INTERNATIONAL RIGHTS RESERVED.

LOC	DBT	REVISIONS			
AF	50	REV	DESCRIPTION	DATE	BY
		B1	REVISED PER ECR-08-016785	25JUL08	HMR GP

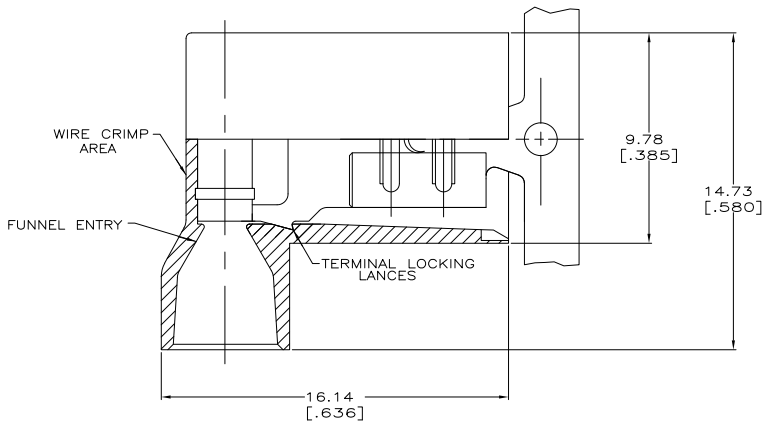

- FITS 0.81±0.025 X 5.21 [.032±.001 X .205] TAB OR 0.81±0.025 X 4.75 [.032±.001 X .187] TAB.
 - WIRE SIZE: 0.3-0.9mm² [22-18 AWG], STRANDED ONLY. STRIP LENGTH 7.92 [.312]
 - INSULATION SIZE: 4.19 [.165] MAX DIA.
 - CONTINUOUS STRIP, SPLICE FREE.
- △5 PRELIMINARY - NOT FOR PRODUCTION

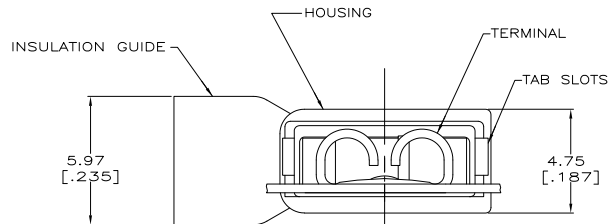
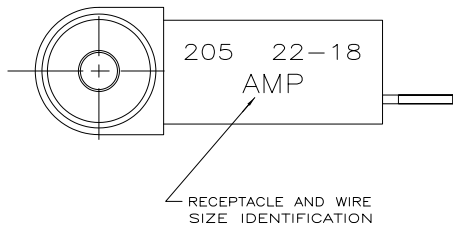

STANDARD	TYPE 6/6 NYLON	BLACK	0.41 [.016] #4H BRASS	TIN	△5 9-521164-2
STANDARD	TYPE 6/6 NYLON	GRAY TRANSLUCENT	0.41 [.016] #4H BRASS	TIN	△5 6-521164-2
STANDARD	TYPE 6/6 NYLON	RED TRANSLUCENT	0.41 [.016] #4H BRASS	TIN	2-521164-2
PACKAGING	MATERIAL	COLOR	MATERIAL	FINISH	

THIS DRAWING IS A CONTROLLED DOCUMENT.		DN	9/12/98	Tyco Electronics Corporation Harrisburg, PA 17105-3608
		MR RUTH	9/12/98	
		DN	9/12/98	Tyco Electronics Corporation Harrisburg, PA 17105-3608
		MS FEHER	9/12/98	
DIMENSIONS: TO DIMENSIONS UNLESS OTHERWISE SPECIFIED:		PRODUCT SPEC: 108-2043		RECEPTACLE ASSEMBLY, ULTRA-FAST FLAG, 5.21 [.205] SERIES
mm [INCHES]		APPLICATION SPEC: 114-2123		
MATERIAL: SEE TABLE		WEIGHT: -		SIZE: A2
FINISH: SEE TABLE		CUSTOMER DRAWING		CAGE CODE: 00779
				DRAWING NO: 521164
				RESTRICTED TO: -
				SCALE: 3:1
				SHEET: 1 of 1
				REV: B1