

2.2 Commercial Standard and Specifications :

- A. JASO D7002 Automotive Multi-Pole Connectors
- B. JASO D7101 Test Methods for Molded Plastic Parts
- C. JIS C3406 Low Voltage Cables for Automobiles
- D. JIS D0203 Method of Moisture, Rain and Spray Test for Automobile Parts
- E. JIS D0204 Method of High and Low Temperature Test for Automobile Parts
- F. JIS D1601 Vibration Testing Method for Automobile Parts
- G. JIS R5210 Portland Cement
- H. JIS C0023 Basic Environmental Testing Procedures Parts Tests-Test Ka : Salt mist

3. Requirements :

3.1 Design and Construction :

Product shall be of the design, construction and physical dimensions specified in the applicable product drawing.

3.2 Materials :

- A. Contact : Pretinned brass or pretinned phosphor bronze
- B. Housing : PBT Molding Compound

3.3 Ratings :

- A. Temperature Rating : -30°C to 105°C
(Ambient Temperature + Temperature Rising by Energized Loading)

3.4 Performance and Test Descriptions :

The product is designed to meet the electrical, mechanical and environmental performance requirements specified in Fig. 2. All tests are performed at ambient temperature, unless otherwise specified.

SHEET 2 OF 11	AMP AMP (Japan), Ltd. Kawasaki, Japan			REV. A
	LOC J	LOC A	NO 108-5303	
NAME Design Objectives "187" Series Connectors				

3.5 Test Requirements and Procedures Summary :

Para.	Test Items	Requirements	Procedures
3.5.1	Confirmation of Product	Product shall be conforming to the requirements of applicable product drawing and Application Specification .	Visually, dimensionally and functionally inspected per applicable quality inspection plan.
3.5.2	Termination Resistance (Low Level)	3 m Ω Max. (Initial) 10 m Ω Max. (Final)	Subject mated contacts assembled in housing to closed circuit current of 10 mA Max. at open circuit voltage of 20 mV Max. Fig. 1. AMP Spec. 109-5311-1
3.5.3	Termination Resistance (Specified Current)	3 mV/A MAX (Initial) 10 mV/A MAX (Final)	Measure initial millivolt drop of contact test circuit in mated connectors, Fig. 1. AMP Spec. 109-5311-2
3.5.4	Insulation Resistance	100 M Ω Min. (Final)	Impressed voltage 500 V DC. Test between adjacent circuits of mated connectors. AMP Spec. 109-5302 Fig. 2
3.5.5	Dielectric Strength	No creeping discharge nor flashover shall occur.	1.0 KVAC for 1 minute. Test between adjacent circuits of mated connectors. AMP Spec. 109-5301 Fig. 2
3.5.6	Current Leakage	3 mA Max.	12 V DC 60 °C Humidity 90~95 % 1 Hr AMP Spec. 109-5312 Fig. 3
3.5.7	Current Cycling	10 m Ω Max. (Final) No ignition is allowed during the test.	Applied Corrent : I \times kd Fig. 4, 5. 45 minutes "ON", 15 minutes "OFF" 300 cycles. 50 % current to be applied to contacts excepting 4 positions in the center area of connector. AMP Spec. 109-5308

Fig. 2 (To be continued)

SHEET 3 OF 11	AMP AMP (Japan), Ltd. Kawasaki, Japan		
	LOC J	LOC A	NO 108-5303
NAME Design Objectives "187" Series Connectors			
			REV. A

NUMBER:
108-5303Customer
ReleaseSECURITY
CLASSIFICATION:

Para.	Test Items	Requirements				Procedures
3.5.8	Temperature Rising	60 °C Max. under loaded specified current.				Measure temperature rising by energized current. Applied Current : I × kd Fig. 4, 5 AMP Spec. 109-5310 method
3.5.9	Handling Ergonomics	No abnormalities allowed in manual mating / unmating handing.				Manually operated
3.5.10	Crimp Tensile Strength	Wire Size		Crimp Tensil (min.)		Apply an axial pull-off load to crimped wire of contact secured on the tester, Operation Speed : 100 mm / min. AMP Spec. 109-5205 Condition
		mm ²	(AWG)	N	(kgf)	
		0.3	#22	78.5	8	
		0.5	#20	88.3	9	
		0.85	#18	127	13	
		1.25	#16	177	18	
2.0	#14	265	27			
3.0	#12	294	30			
3.5.11	Contact Retention Force with Spencer	98 N (10 kgf) Min.				Apply an axial pull-off load to crimped wire. Operation Speed : 100 mm / min. AMP Spec. 109-5212
3.5.12	Contact Mating Force	14.7 N (1.5 kgf) Max. per cocntact				Operation of Speed 100 mm / min. Measure the force required to mate AMP Spec. 109-5202 Condition
3.5.13	Connector Mating Force	8 Pos. 98 N (10 kgf) Max.				Operation Speed : 100 mm/ min. Measure the force required to mate connectors. AMP Spec. 109-5206 Condition
3.5.14	Connector Unmating Force	8 Pos. 78.5 N (8 kgf) Max.				Operation Speed : 100 mm / min. Measure the force required to unmate connectors without locking device set in effect. AMP Spec. 109-5206 Condition

Fig. 2 (To be continued)

SHEET	AMP AMP (Japan), Ltd. Kawasaki, Japan			
4 OF 11	LOC J	LOC A	NO 108-5303	REV. A
NAME	Design Objectives "187" Series Connector			

Para.	Test Items	Requirements	Procedures
3.5.15	Connector Locking Strength	98.1 N (10 kgf) Min.	Measure connector locking strength. Operation Speed : 100 mm / min.
3.5.16	Contact Retention Force (Secondary Lock)	98.1 N (10 kgf) Min.	Measure contact retention force with secondary lock set it effect. Operation Speed : 100 mm / min.
3.5.17	Durability (Repeat Mate / Unmating)	10 mΩ Max. (Final)	Operation Speed : 100 mm / min. No. of Cycles : 30 cycles. AMP Spec. 109-5213
3.5.18	Resistance to "Kojiri"	10 mΩ Max. (Final)	Repeat 30 cycles of "Kojiri" mating and unmating test conditioning by hand. AMP Spec. 109-5215
3.5.19	Vibration (High Frequency)	No electrical discontinuity greater than 1 μsec. shall occur. 10 mΩ Max. (Final)	Vibration Frequency : 20~200 Hz / 1 min. Accelerated Velocity : 44 m / s ² (4.5 G) Vibration Direction : X, Y & Z Directions Duration : X & Z Directions : 2 hours Y Directions : 4 hours AMP Spec. 109-5202 Condition
3.5.20	Temperature Life (Hear Aging)	10 mΩ Max. (Final)	120 °C. Duration : 120 hours AMP Spec. 109-5104- Condition
3.5.21	Resistance to Cold	10 mΩ Max. (Final)	- 50 °C ± 5 °C, 120 hours AMP Spec. 109-5108-
3.5.22	Thermal Shock	10 mΩ Max. (Final)	- 30 °C / 2 hours 80 °C / 2 hours Making this a cycle, repeat 5 cycles. AMP Spec. 109-5103 Condition
3.5.23	Humidity, Steady State	Termination resistance 10 mΩ Max. (Final)	Mated / unmated Connector, 90~95 % R. H. 60 °C 96 hours AMP Spec. 109-5105

Fig. 2 (To be continued)

SHEET	AMP AMP (Japan), Ltd. Kawasaki, Japan			
5 OF 11	LOC J	LOC A	NO 108-5303	REV. A
NAME	Design Objectives "187" Series Connector			

108-5303

NUMBER:

Customer Release

SECURITY CLASSIFICATION:

Para.	Test Items	Requirements	Procedures
3.4.24	Salt Spray	10 mΩ Max. (Final)	Subject mated connectors to 5 % salt spray exposure for 192 hours with 1 hour suspension in a halfway. Measurement shall be made after 1 hour drying after rinsing by tap water, after completion of exposure, per JIS C 5028.
3.4.25	Dust Bombardment	10 mΩ Max. (Final)	Subject mated connectors to 90-minute cement blow, dispersed by compressed air at a rate of 1.5 kg per 10 seconds in intervals of 15 minutes. Cement to be conforming to JIS R 5210, Portland Cement AMP Spec. 109-5110
3.5.26	Icing	10 mΩ Max. (Final)	Immerse in boiling water for 1 hours freeze at - 30 °C
3.5.27	Industrial Gas (SO ₂)	10 mΩ Max. (Final)	SO ₂ Gas : 10 ppm, 95 % R.H. Room temperature for 24 hours. AMP Spec. 109-5107 Condition
3.5.28	Resistance to Oil	10 mΩ Max. (Final)	Immerse mated connectors in oil. 50 ± 5 °C See Fig. 7

Fig. 2 (End)

SHEET	AMP AMP (Japan), Ltd. Kawasaki, Japan		
6 OF 11	LOC J	LOC A	NO 108-5303
NAME	Design Objectives "187" Series Connector		
			REV. A

2. Product Qualification Test Sequence

Test or Examination	Test Group						
	1	2	3	4	5	6	7
	Test Sequence (a)						
Confirmation of Product	1	1	1	1	1	1	1, 16, 22
Termination Resistance (Rated Current)	4			4, 12, 15, 18, 22, 25	3, 6, 9, 12, 16	3, 6, 9	3, 9, 12, 15, 19
Termination Resistance (Low Level)	3			3, 11, 14, 17, 21, 24	2, 5, 8, 11, 15	2, 5, 8	2, 8, 11, 14, 18
Dielectric Strength				7			6, 20
Insulation Resistance				6			5
Current Leakage				5, 19	13		4, 21
Temperature Rising				23			
Current Cycling				20			
Vibration (High Frequency)						7	
Connector Mating Force				2			
Connector Unmating Force				8			
Contact Retention Force				28			
Contact Retention Force (Secondary Lock)			3			12	
Contact Mating Force	2		2				
Contact Unmating Force	5						
Crimp Tensile Strength		2					
Durability (Repeat Mate / Unmating)							7
Housing Locking Strength				27		11	
Resistance to "Kojiri"				10		4	
Handing Ergonomics	6			9, 26		10	23
Thermal Shock					14		
Humidity (Steady State)					10		
Salt Spray							10
Industrial Gas (SO ₂)							17
Temperature Life (Heat Aging)					4		
Resistance to Cold					7		
Icing				16			
Resistance to Oil							13
Dust Bombardment				13			

(a) Numbers indicate the sequence in which the tests are performed.

SHEET

AMPAMP (Japan), Ltd.
Kawasaki, Japan

7 OF 11

LOC
JLOC
A

NO

108-5303

REV.

0

NAME

Design Objectives
"187" Series ConnectorNUMBER:
108-5303SECURITY CLASSIFICATION:
Customer Release

SECURITY CLASSIFICATION:

The applicable product descriptions and part numbers are as shown Appendix 1.

Product Part No.	Description
175044	"187" Series Tab Contact (0.3~0.5 mm ²)
175046	"187" Series Tab Contact (0.5~1.25 mm ²)
175048	"187" Series Tab Contact (2.0~3.0 mm ²)
175038	"187" Series Receptacle Contact (0.3~0.5 mm ²)
175040	"187" Series Receptacle Contact (0.5~1.25 mm ²)
175042	"187" Series Receptacle Contact (2.0~3.0 mm ²)
175987	8 Pos. Cap Housing Assembly
175979	8 Pos. Plug Housing Assembly

Appendix 1

SHEET	AMP AMP (Japan), Ltd. Kawasaki, Japan			
8 OF 11	LOC J	LOC A	NO 108-5303	REV. A
NAME	Design Objectives "187" Series Connector			

NUMBER: 108-5303

CUSTOMER
RELEASE

SECURITY
CLASSIFICATION:

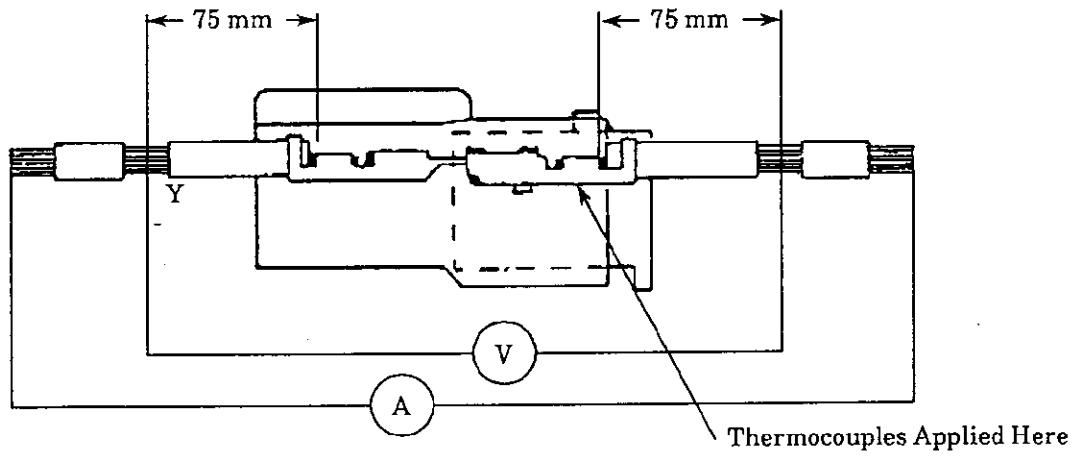

Fig. 1

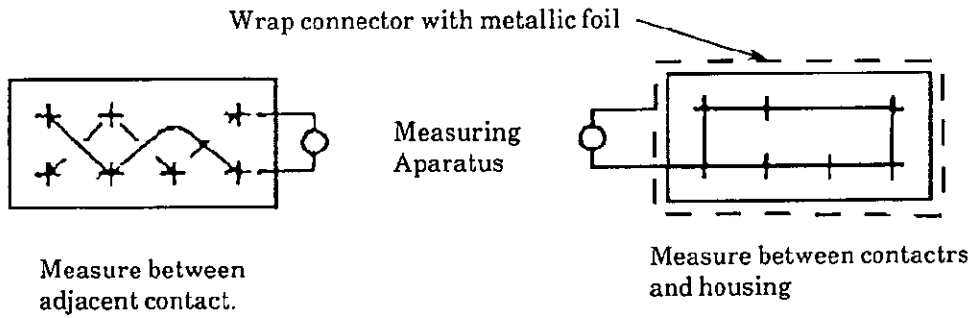

Fig. 2

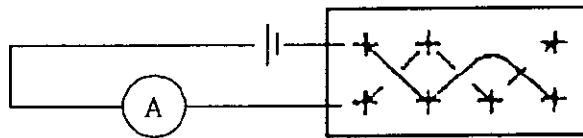

Fig. 3

SHEET	AMP AMP (Japan), Ltd. Kawasaki, Japan		
9 OF 11	LOC J	LOC A	NO 108-5303
NAME			REV. A
Design Objectives "187" Series Connector			

100-0000

Release

Wire Size	I (Amperes)
0.3 mm ²	8.0 Dc.
0.5 mm ²	11.0 Dc.
0.85 mm ²	15.0 Dc.
1.25 mm ²	19.0 Dc.
2 mm ²	25.0 Dc.
3 mm ²	34.0 Dc.

Fig. 4

Number of Positions	kd (Reduction Coefficient)
1	1
2-3	0.75
4-5	0.6
6-8	0.55
9-12	0.5
13 and over	0.4

Fig. 5

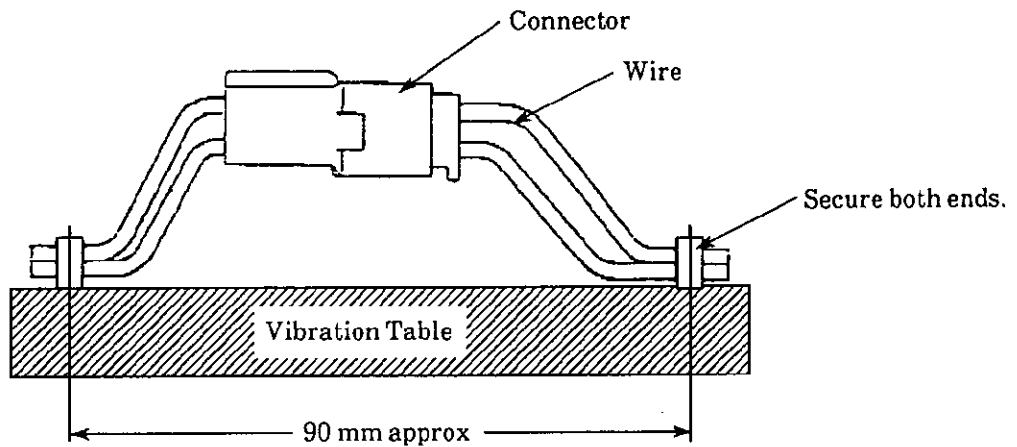

Fig. 6

SHEET	AMP AMP (Japan), Ltd. Kawasaki, Japan			
	10 OF 11	LOC J	LOC A	NO 108-5303
NAME	Design Objectives "187" Series Connector			

SECURITY CLASSIFICATION: Customer Release NUMBER: 108-5303

Test Step	Oil Name	Duration
1	Torque Converter Oil	1 hour
2	Transmission Oil	1 hour
3	Engine Oil	1 hour
4	Clutch Oil	1 hour
5	Brake Oil	1 hour

Fig. 7

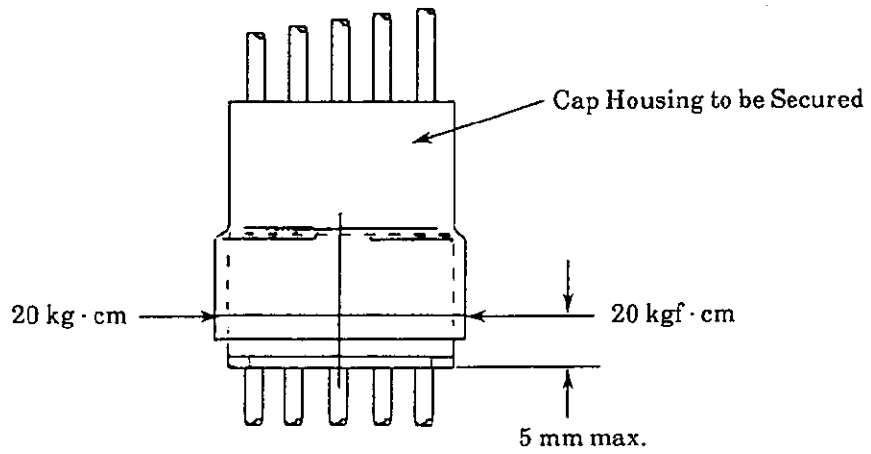

Fig. 8

SHEET	AMP			AMP (Japan), Ltd. Kawasaki, Japan
	11 OF 11	LOC J	LOC A	NO 108-5303
NAME		Design Objectives "187" Series Connector		
REV.		A		