

4

3

2

1

THIS DRAWING IS UNPUBLISHED. RELEASED FOR PUBLICATION
 © COPYRIGHT - By - ALL RIGHTS RESERVED.

LOC	DIST	REVISIONS			
P	LTR	DESCRIPTION	DATE	DWN	APVD
FT	0				
	F2	REVISED PER ECO-11-004820	11MAR11	RK	HMR

PHYSICAL PROPERTIES:
 HOUSING MATERIAL: PBT
 FLAMMABILITY: UL94V-0
 COLOR: BLACK

TERMINAL:
 TERMINALS: BRASS, TIN PLATED
 SCREWS: 8-32 STEEL, NICKEL PLATED

MECHANICAL:
 PITCH (TERMINAL SPACING): .563"
 WIRE RANGE: 10-22 AWG
 RECOMMENDED TIGHTENING TORQUE: 14IN-LBS MAX.

ELECTRICAL PROPERTIES:
 MAXIMUM CURRENT: 30A
 OPERATING VOLTAGE: 300V

ENVIRONMENTAL PROPERTIES:
 OPERATING TEMP RANGE: -40°C TO 120°C

- 1 PARTS SUPPLIED WITH SCREWS UNINSTALLED.
- 2 PRELIMINARY PART NUMBER.
- 3 TE CONNECTIVITY LOGO LOCATED APPROXIMATE AREA SHOWN.

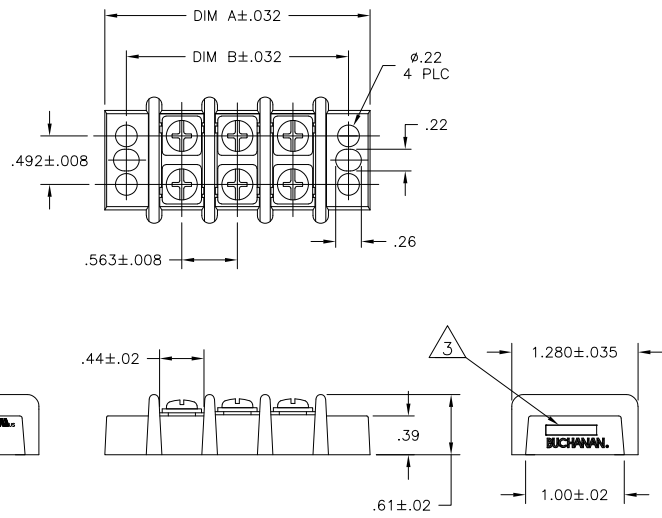

10.701	11.138	18	1-1546311-8
10.138	10.575	17	1-1546311-7
9.575	10.012	16	1-1546311-6
9.012	9.449	15	1-1546311-5
8.449	8.886	14	1-1546311-4
7.886	8.323	13	1-1546311-3
7.323	7.760	12	1-1546311-2
6.760	7.197	11	1-1546311-1
6.197	6.634	10	1-1546311-0
5.634	6.071	9	2-1546311-1
5.634	6.071	9	1546311-9
5.071	5.508	8	2-1546311-0
5.071	5.508	8	1546311-8
4.508	4.945	7	1546311-7
3.945	4.382	6	1546311-6
3.382	3.819	5	1546311-5
2.819	3.256	4	1-1546311-9
2.819	3.256	4	1546311-4
2.256	2.693	3	1546311-3
1.693	2.130	2	1546311-2
DIM B	DIM A	NO. OF POSN	BUCHANAN PART NO.

THIS DRAWING IS A CONTROLLED DOCUMENT.

DIMENSIONS: INCHES	TOLERANCES UNLESS OTHERWISE SPECIFIED:	DWN S SCHLEGEL 20AUG2002	TE Connectivity	
0 PLC ± -	1 PLC ± -	CHK C RICHARD 8/20/02	NAME .563 DBL ROW BARRIER STRIP W/ WASHER	
1 PLC ± -	2 PLC ± .01	APVD C RICHARD 8/20/02	PRODUCT SPEC	
2 PLC ± .005	3 PLC ± -	APPLICATION SPEC	SIZE A3	CAGE CODE C-1546311
3 PLC ± -	4 PLC ± -	WEIGHT -	RESTRICTED TO	
4 PLC ± -	ANGLES ± -	MATERIAL -	CUSTOMER DRAWING	SCALE NTS SHEET 1 of 1 REV F2