

4

3

2

1

THIS DRAWING IS UNPUBLISHED. RELEASED FOR PUBLICATION  
 © COPYRIGHT - BY TYCO ELECTRONICS CORPORATION. ALL RIGHTS RESERVED.

LOC		DIST		REVISIONS			
P	LTR	DESCRIPTION		DATE	DWN	APVD	
	AF1	REVISED PER ECO-06-018765		13APR07	DH	DB	

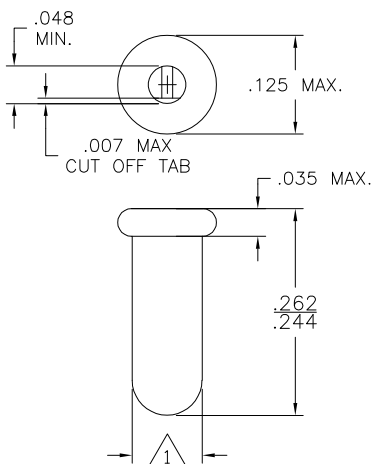

1 PART FITS INTO A #43 DRILLED HOLE(.089±.0015) FOR HAND INSERTION AND A #44 DRILLED HOLE(.086±.0015) FOR MACHINE INSERTION.

2 .145 MIN. INSERTION DEPTH REQUIRED FOR A RELIABLE CONNECTION.

3. SPRING TO BE SECURED IN CUP WITH NO SPRING ROTATION PERMISSIBLE.

4. LEAD RANGES & PERFORMANCE RESULTS.

LEAD RANGES (DIA)	.018-.020	.025-.032	.035-.040
MAX. INSERTION FORCE	17 oz.	37 oz.	48 oz.
MIN. EXTRACTION FORCE	1.0 oz.	1.5 oz.	2.0 oz.
MILLIVOLT DROP (MAX.)	2.00 MV	1.75 MV	1.50 MV

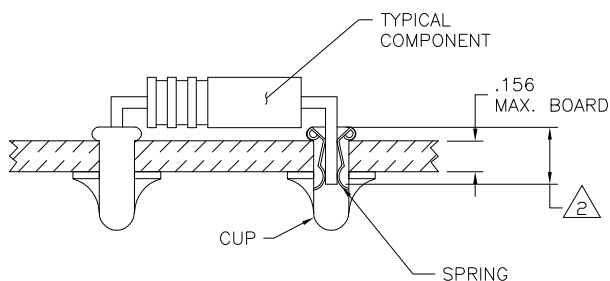

OBSOLETE	.000150 MIN BRIGHT TIN	.000030 MIN GOLD OVER .000030 MIN NICKEL	380598-6
OBSOLETE	.000050 MIN GOLD OVER .000050 MIN NICKEL	.000050 MIN GOLD OVER .000050 MIN NICKEL	380598-5
OBSOLETE	TIN-LEAD	TIN-LEAD	380598-4
OBSOLETE		TIN-LEAD	380598-3
		.000030 MIN GOLD OVER .000030 MIN NICKEL	380598-2
	.000030 MIN GOLD OVER .000030 MIN NICKEL	.000030 MIN GOLD OVER .000030 MIN NICKEL	380598-1
NOTES	FINISH		PART NO.
THIS DRAWING IS A CONTROLLED DOCUMENT.		DWN D. HUMBERT 13APR2007	Tyco Electronics Corporation Harrisburg, PA 17105-3608
DIMENSIONS: INCHES	TOLERANCES UNLESS OTHERWISE SPECIFIED:	CHK -	NAME REUSEABLE COMPONENT RECEPTACLE
	0 PLC ± -	APVD -	SIZE A3
	1 PLC ± -	PRODUCT SPEC -	CAGE CODE 00779
	2 PLC ± -	APPLICATION SPEC -	DRAWING NO C-380598
	3 PLC ± -	WEIGHT -	RESTRICTED TO -
	4 PLC ± -		
	ANGLES ± -		
MATERIAL CUP - Cu SPRING - BeCu	FINISH SEE TABLE	CUSTOMER DRAWING	SCALE NTS
		SHEET 1 OF 1	REV AF1