

4

3

2

1

THIS DRAWING IS UNPUBLISHED. RELEASED FOR PUBLICATION  
 COPYRIGHT © BY TYCO ELECTRONICS CORPORATION. ALL RIGHTS RESERVED.

LOC	DIST	REVISIONS			
P	LTR	DESCRIPTION	DATE	DWN	APVD
C		REVISED (ECR-11-009438)	05MAY11	JL	WK

NOTE:  
 1. MATERIAL:  
 HOUSING: LCP WITH 30% GF, UL 94V-0, WHITE COLOR.  
 EJECTOR: LCP WITH 30% GF, UL 94V-0, BLACK COLOR.  
 PICKPAD: LCP WITH 30% GF, UL 94V-0, BLACK COLOR.  
 CONTACTS: BRASS.  
 BOARDLOCKS: BRASS.  
 PIVOT SHELL: STEEL.  
 2. FINISH:  
 CONTACTS: 0.381μm [15μ] GOLD PLATED ON CONTACT AREA,  
 2.54μm [100μ] MIN. MATTE-TIN ON SOLDER TAIL, WITH  
 ENTIRE CONTACT UNDERPLATED 1.27μm [50μ] MIN. NICKEL.  
 MOUNT EAR: 2.54μm [100μ] MIN. TIN PLATED ON SOLDER AREA  
 1.27μm [50μ] MIN. UNDERPLATED ALL OVER.  
 3. REFLOW SOLDER CAPABLE TO 260°C PER TE TEST SPEC.  
 109-201, CONDITION B.  
 4. MEET COMPACT FLASH INDUSTRY STANDARD.  
 5.  $\Delta$  CTQ DIMENSION FOR SPECIAL CONTROL

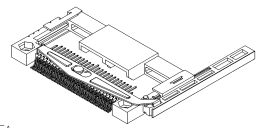

POWER	5.00mm
GENERAL	4.25mm
DETECT	3.50mm
PIN TYPE	INTERFACE DIM. L

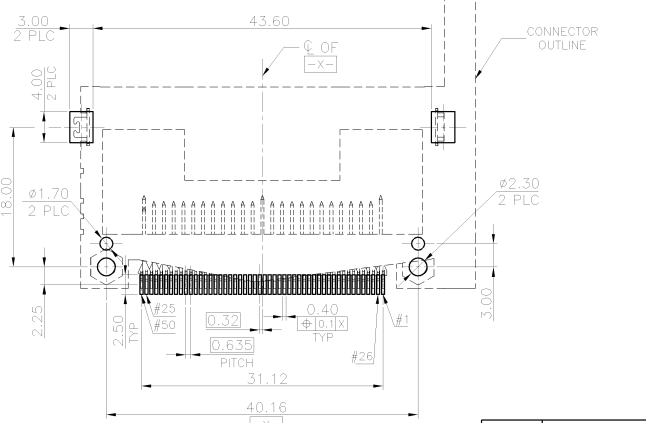
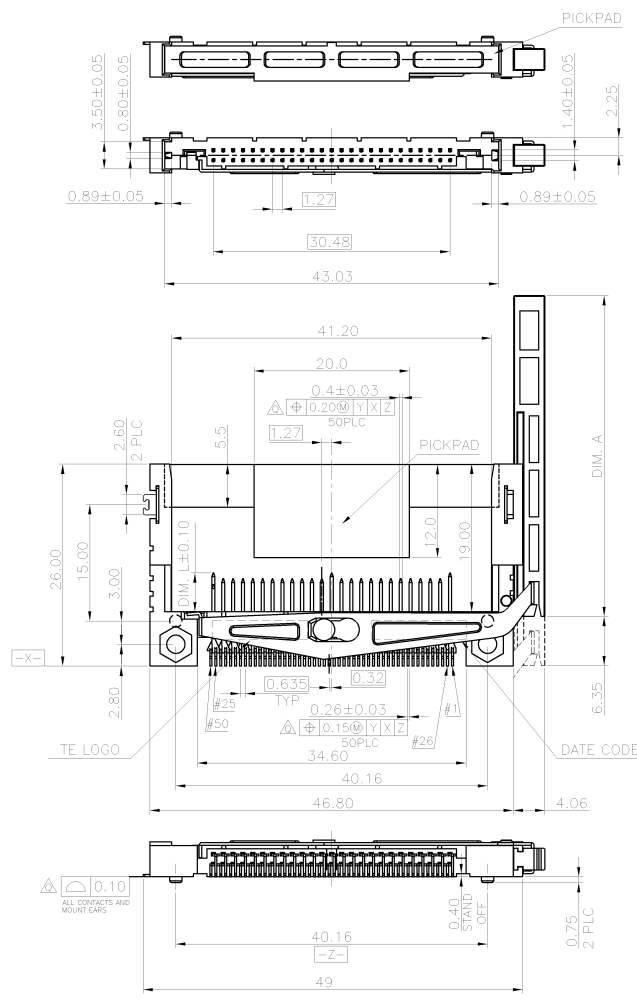

34.70	1734909-2
41.30	1734909-1
DIM. A	PART NUMBER

THIS DRAWING IS A CONTROLLED DOCUMENT.		DWN S. CHIEN 16JUL2008		Tyco Electronics Corporation	
DIMENSIONS: MM		CHK S. CHIEN 16JUL2008		Tyco Electronics Corporation	
TOLERANCES UNLESS OTHERWISE SPECIFIED:		APVD W. KODAMA 16JUL2008		Taipei, Taiwan	
0 PLC ±0.5		NAME		PIN HEADER, 50 POS, SMT, WITH EJECTOR, COMPACT FLASH CARD	
1 PLC ±0.3		PRODUCT SPEC		108-57134	
2 PLC ±0.2		QUALIFICATION TEST REPORT		501-57118	
3 PLC ±		WEIGHT		4.54 GRAMS	
4 PLC ±		SIZE		A3	
ANGLES ±		CAGE CODE		00779	
FINISH		DRAWING NO		1734909	
SEE NOTE		CUSTOMER DRAWING		RESTRICTED	
		SCALE		SHEET 1 OF 2	
				REV C	

AMP 1470-19 REV 31MAR2000

4

3

2

1

THIS DRAWING IS UNPUBLISHED. RELEASED FOR PUBLICATION  
 © COPYRIGHT - BY TYCO ELECTRONICS CORPORATION. ALL RIGHTS RESERVED.

LOC	DIST	REVISIONS				
P	LTR	DESCRIPTION	DATE	DWN	APVD	
		SEE SHEET 1.				

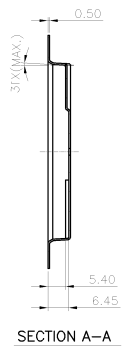
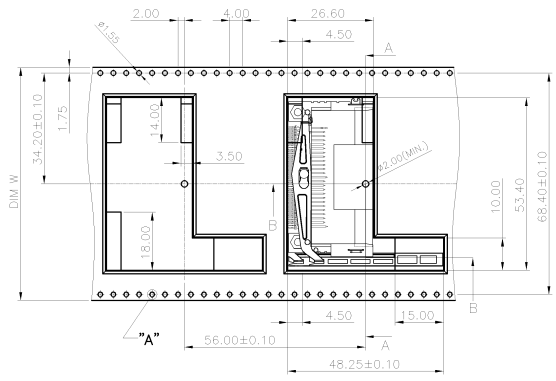
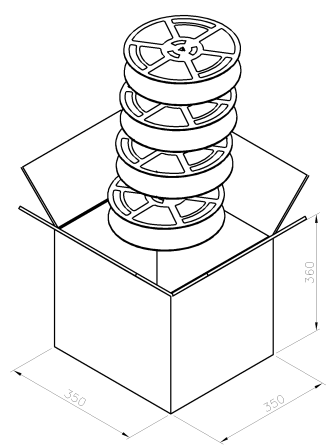
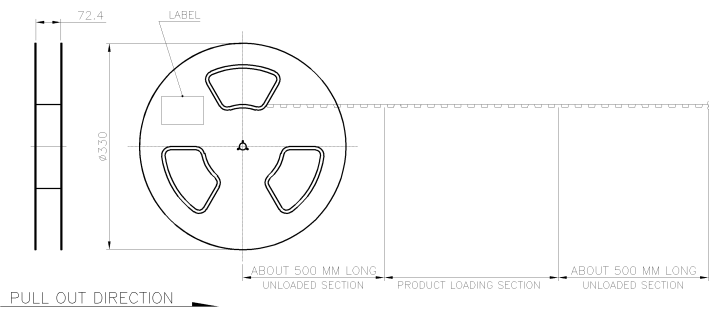

72	110	4	440	6	5.5
DIM W	PCS/TAPE	REELS/CARTON	QUANTITY (PCS)	G/W (Kg)	N/W (Kg)

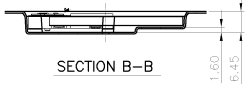
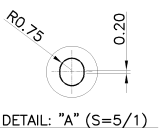

THIS DRAWING IS A CONTROLLED DOCUMENT.

DIMENSIONS: MM	TOLERANCES UNLESS OTHERWISE SPECIFIED	DWN	CHK	APVD	NAME
0 PLC	±				
1 PLC	±				
2 PLC	±				
3 PLC	±				
4 PLC	±				
ANGLES	±				
MATERIAL	FINISH	PRODUCT SPEC	APPLICATION SPEC	WEIGHT	RESTRICTED?

**Tyco Electronics** Tyco Electronics Corporation  
Taipei, Taiwan

**PIN HEADER, 50 POS, SMT, WITH EJECTOR, COMPACT FLASH CARD**

SIZE: A3 CAGE CODE: 00779 DRAWING NO: 1734909

CUSTOMER DRAWING SCALE: SHEET 2 of 2 REV C

AMP 1470-19 REV 31MR2000