

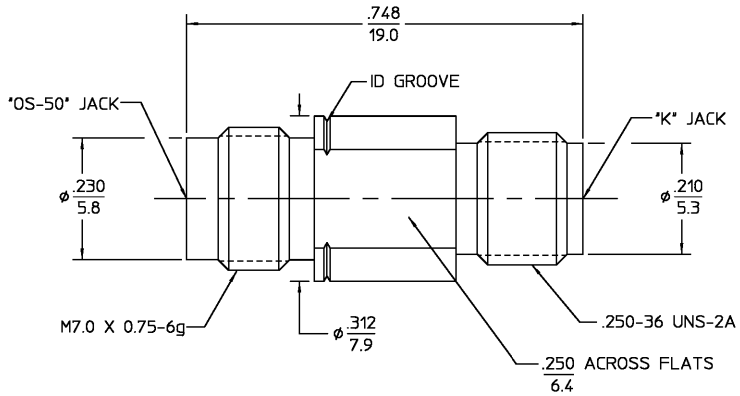

REVISIONS			
REV	DESCRIPTION	DATE	APPROVED
01 <sub>1</sub>	REVISED	11/28/88	<i>[Signature]</i>



COMPONENT	MATERIAL	FINISH
HOUSING INNER SLEEVE	STAINLESS STEEL PER ASTM-A484 AND ASTM-A582, TYPE 303	PASSIVATE PER QQ-P-35
DIELECTRIC	TFE FLUOROCARBON PER ASTM-D-1457	N/A
CENTER CONTACT	BERYLLIUM COPPER PER ASTM-B-196 OR ASTM-B-197, ALLOY C17300, CONDITION H	GOLD PLATE PER MIL-G-45204

UNLESS OTHERWISE SPECIFIED DIMENSIONS ARE IN INCHES FRAC. ± 1/64 DEC. ± .005 ANGLES ± °	DRAWN BY DAC	DATE 11/18/88	 AMP Incorporated 140 Fourth Avenue Waltham, MA 02451-7599
	CHECKED BY DAL	DATE 11/23/88	
These drawings and specifications are the property of M/A CDM Interconnect Div. and shall not be reproduced or copied or used in whole or in part as the basis for the manufacture or sale of items without written permission.	USE ASSY PROCEDURE	TITLE OS-50 JACK TO OS 2.9 JACK	
	NO. AP. N/A	SIZE B	CODE IDENT NO. 26805
		SCALE 6:1	8580-2361-02
			SHEET 1 OF 1

NOTES:  
1. CAPTURED CENTER CONTACT

.XXX = in  
XX.X = mm (REF)

CUSTOMER DRAWING

AMP PART # 1063383-1  
SHEET 1 OF 1 REV A