

THIS DRAWING IS UNCLASSIFIED  
 UNLESS INDICATED OTHERWISE  
 BY THE ELECTRONICS CORPORATION. ALL RIGHTS RESERVED.

REVISE		REVISIONS			
DATE	BY	DESCRIPTION	DATE	BY	APP'D
CM	00	REVISED PER 6638-1100-04			

1. PARTS COMPLY TO AMP SOLDERABILITY SPECIFICATION 109-11-3.
- △ CONTACT IS PLATED OVERALL WITH 0.00127 (.000050) NICKEL, THEN STRIPED WITH 0.00076 (.000030) GOLD IN CONTACT AREA AND TIN-LEAD ON SOLDER TAIL END.
  - △ CIRCUIT IDENTIFICATION CHARACTERS ARE ADJACENT TO THE INDICATED CAVITIES, BUT LOCATION AND ORIENTATION MAY DIFFER FROM PRINT.
  - △ CONTACT IS PLATED OVERALL WITH 0.00127 (.000050) NICKEL, THEN 0.00076 (.000030) GOLDOVER CONTACT LENGTH INDICATED AND MATTE TIN ON SOLDER TAIL END.

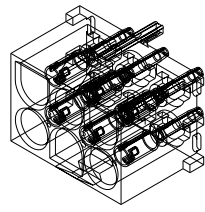
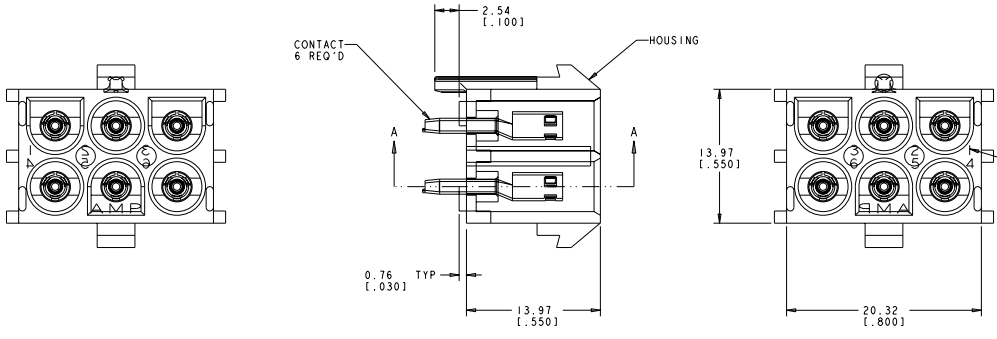

SCALE 4:1

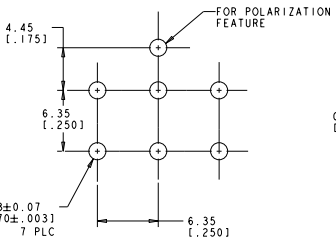

RECOMMENDED MOUNTING HOLE PATTERN FOR 1.57 (.062) THICK P.C. BOARD

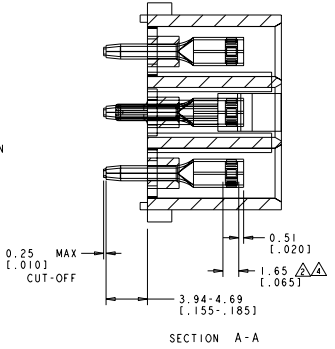

SECTION A-A



△ PHOSPOR BRONZE, GOLD	NYLON, UL94V-0	643424-3
△ PHOSPOR BRONZE, GOLD	NYLON, UL94V-0	643424-2
△ PHOSPOR BRONZE, PRE-TIN	NYLON, UL94V-0	643424-1
CONTACT	HOUSING	PART NUMBER

DIMENSIONS (MILLIMETERS) DIMENSIONS (INCHES)	DIMENSIONS (MILLIMETERS) DIMENSIONS (INCHES)	DIMENSIONS (MILLIMETERS) DIMENSIONS (INCHES)	DIMENSIONS (MILLIMETERS) DIMENSIONS (INCHES)	DIMENSIONS (MILLIMETERS) DIMENSIONS (INCHES)	DIMENSIONS (MILLIMETERS) DIMENSIONS (INCHES)
SEE TABLE	SEE TABLE	SEE TABLE	SEE TABLE	SEE TABLE	SEE TABLE

CUSTOMER DRAWING