Connector, Universal MATE-N-LOK* II

DESIGN OBJECTIVES

The product described in this document has not been fully tested to ensure conformance to the requirements outlined below. Therefore AMP* Incorporated makes no representation or warranty, express or implied, that the product will comply with these requirements. Further, AMP Incorporated may change these requirements based on the results of additional testing and evaluation. Contact AMP Engineering for further details.

1. SCOPE

1.1. Content

This specification covers performance, tests and quality requirements for universal MATE-N-LOK* II connectors. These connectors provide a means of grouping multi-lead connections in home entertainment centers, appliances, vending machines, computers, and other commercial equipment.

1.2. Qualification

When tests are performed on the subject product line, procedures specified in Figure 1 shall be used. All inspections shall be performed using the applicable inspection plan and product drawing.

2. APPLICABLE DOCUMENTS

The following documents form a part of this specification to the extent specified herein. Unless otherwise specified, the latest edition of the document applies. In the event of conflict between the requirements of this specification and the product drawing, the product drawing shall take precedence. In the event of conflict between the requirements of this specification and the referenced documents, this specification shall take precedence.

2.1. AMP Documents

- A. 109-1: General Requirements for Test Specifications
- B. 109 Series: Test Specifications as indicated in Figure 1
- C. Corporate Bulletin 401-76: Cross-reference between AMP Test Specifications and Government or Commercial Documents
- D. 114-1043: Application Specification
- E. 501- : Qualification Test Report

3. REQUIREMENTS

3.1. Design and Construction

Product shall be of the design, construction and physical dimensions specified on the applicable product drawing.

3.2. Materials

Materials used in the construction of this product shall be as specified on the applicable product drawing.

PRELIMINARY

3.3. Ratings

- A. Voltage: 600 vac
- B. Current: See Figure 4 for applicable current carrying capability. Maximum rated current that can be carried by this product is limited by the maximum operating temperature of the housings (90°C) and temperature rise of the contacts (30°C). Variables which shall be considered for each application are wire size, connector size, contact material, and ambient temperature.
- C. Temperature: -55 to 120°C

3.4. Performance and Test Description

Product is designed to meet the electrical, mechanical and environmental performance requirements specified in Figure 1. Unless otherwise specified, all tests shall be performed at ambient environmental conditions per AMP Specification 109-1.

3.5. Test Requirements and Procedures Summary

Test Description	Requirement	Procedure
Examination of product.	Meets requirements of product drawing and AMP Spec 114-1043.	Visual, dimensional and functional per applicable quality inspection plan.
ELECTRICAL		
Dry circuit resistance.	3.5 milliohms maximum initial. 10 milliohms maximum final.	AMP Spec 109-6-6. Subject samples to 20 mv maximum open circuit at 100 ma maximum. See Figure 3.
Insulation resistance.	1000 megohms minimum initial. 100 megohms minimum final.	AMP Spec 109-28-4. Test between adjacent contacts.
Dielectric withstanding voltage.	5 kv (rms) at sea level initial. 3.5 kv (rms) at sea level final. 1 minute hold with no breakdown or flashover.	AMP Spec 109-29-1. Test between adjacent contacts.
Temperature rise vs current.	30°C maximum temperature rise at specified current.	AMP Spec 109-45-2. Measure temperature rise vs current. See Figure 4.

Figure 1 (cont)

Test Description	Requirement	Procedure																								
MECHANICAL																										
Crimp tensile.	<table border="1"> <thead> <tr> <th>Wire Size AWG</th> <th>Crimp Tensile Pounds Minimum</th> </tr> </thead> <tbody> <tr><td>30</td><td>1.5</td></tr> <tr><td>28</td><td>3</td></tr> <tr><td>26</td><td>5</td></tr> <tr><td>24</td><td>8</td></tr> <tr><td>22</td><td>14</td></tr> <tr><td>20</td><td>14</td></tr> <tr><td>18</td><td>30</td></tr> <tr><td>16</td><td>45</td></tr> <tr><td>14</td><td>50</td></tr> <tr><td>12*</td><td>60</td></tr> <tr><td>10*</td><td>70</td></tr> </tbody> </table> <p>* Crimp tensile of wire exceeds tensile strength of contact.</p>	Wire Size AWG	Crimp Tensile Pounds Minimum	30	1.5	28	3	26	5	24	8	22	14	20	14	18	30	16	45	14	50	12*	60	10*	70	AMP Spec 109-16. Determine crimp tensile at a maximum rate of 1 inch per minute.
Wire Size AWG	Crimp Tensile Pounds Minimum																									
30	1.5																									
28	3																									
26	5																									
24	8																									
22	14																									
20	14																									
18	30																									
16	45																									
14	50																									
12*	60																									
10*	70																									
Vibration, sinusoidal.	No discontinuities of 1 microsecond or longer duration. See Note.	AMP Spec 109-21-1. Subject mated samples to 10-55-10 Hz traversed in 1 minute with 0.06 inch maximum total excursion. 2 hours in each of 3 mutually perpendicular planes. See Figure 5A.																								
Vibration, random.	Energize at specified current. See Note.	AMP Spec 109-21-7. Subject mated samples to 3.13 G's rms between 5-500 Hz. 15 minutes in each of 3 mutually perpendicular planes. See Figure 5B.																								
Mechanical shock, specified pulse.	No discontinuities of 1 microsecond or longer duration. See Note.	AMP Spec 109-26-1. Subject mated samples to 50 G's half-sine shock pulses of 11 milliseconds duration. 3 shocks in each direction applied along 3 mutually perpendicular planes, 18 total shocks. See Figures 5A and 5B.																								
Durability.	See Note.	AMP Spec 109-27. Manually mate and unmate samples for 50 cycles at a maximum rate of 600 cycles per hour.																								
Contact retention.	35 pounds minimum.	AMP Spec 109-30, except grip wire. Apply axial load to contact at a maximum rate of 0.5 inch per minute.																								
Contact insertion force.	6 pounds maximum per contact.	AMP Spec 109-41. Measure force necessary to insert a contact straight into the rear of a pre-staged housing.																								

Figure 1 (cont)

Test Description	Requirement	Procedure
Mating force.	1.5 pounds maximum per contact.	AMP Spec 109-42, Condition A. Measure force necessary to mate samples.
Unmating force.	0.2 pound minimum per contact.	AMP Spec 109-42, Condition A. Measure force necessary to unmate samples with locking latches disengaged.
Housing panel retention.	75 pounds minimum.	AMP Spec 109-49. Measure panel retention force using nominal panel cut out dimensions specified in the AMP customer drawing.
Housing lock strength.	35 pounds minimum.	AMP Spec 109-50. Determine strength of housing locking mechanism.
Staging latch strength.	50 pounds minimum.	AMP Spec 109-50. Determine strength of staging latch.
ENVIRONMENTAL		
Thermal shock.	See Note.	AMP Spec 109-22. Subject samples to 25 cycles between -55 and 85°C.
Humidity-temperature cycling.	See Note.	AMP Spec 109-23-3, Condition B. Subject samples to 10, 24 hour cycles between 25 and 65°C at 95% RH.
Temperature life.	See Note.	AMP Spec 109-43. Subject mated samples to temperature life at 120°C for 500 hours.

NOTE *Shall meet visual requirements, show no physical damage, and meet requirements of additional tests as specified in the Product Qualification and Requalification Test Sequence shown in Figure 2.*

Figure 1 (end)

3.6. Product Qualification and Requalification Test Sequence

Test or Examination	Test Group (a)					
	1	2	3	4	5	6
	Test Sequence (b)					
Examination of product	1,9	1,9	1,8	1,3	1,4	1,5
Dry circuit resistance	3,7	2,7				
Insulation resistance			2,6			
Dielectric withstanding voltage			3,7			
Temperature rise vs current		3,8				
Crimp tensile				2		
Vibration, sinusoidal	5					
Vibration, random		6(c)				
Mechanical shock	6					
Durability	4					
Contact retention					3	
Contact insertion force					2	
Mating force	2					
Unmating force	8					
Housing panel retention						4
Housing lock strength						3
Staging latch strength						2
Thermal shock			4			
Humidity-temperature cycling		4(d)	5			
Temperature life		5				

NOTE

- (a) See Para 4.1.A.
- (b) Numbers indicate sequence in which tests are performed.
- (c) Discontinuities shall not be measured. Energize at 18°C level for 100% loadings per AMP Specification 109-151.
- (d) Precondition samples with 5 cycles durability.

Figure 2

4. QUALITY ASSURANCE PROVISIONS

4.1. Qualification Testing

A. Sample Selection

Samples shall be prepared in accordance with applicable Instruction Sheets and shall be selected at random from current production. Test group 1 shall consist of 8, 4 position connector assemblies and 3, 12 position connector assemblies panel mounted per Figure 5A, all terminated to 14 AWG wire. Test group 2 shall consist of the following wire-to-wire assemblies per Figure 5B: 8, 4 position in-line connector assemblies terminated to 20 AWG wire; 8, 4 position connector assemblies terminated to 10 AWG wire; 3, 12 position matrix connector assemblies terminated to 20 AWG wire; and 3, 12 position matrix connector assemblies terminated to 10 AWG wire. Test group 3 shall consist of 5, 12 position matrix connector assemblies terminated to 12 AWG wire.

B. Test Sequence

Qualification inspection shall be verified by testing samples as specified in Figure 2.

4.2. Requalification Testing

If changes significantly affecting form, fit or function are made to the product or manufacturing process, product assurance shall coordinate requalification testing, consisting of all or part of the original testing sequence as determined by development/product, quality and reliability engineering.

4.3. Acceptance

Acceptance is based on verification that the product meets the requirements of Figure 1. Failures attributed to equipment, test setup or operator deficiencies shall not disqualify the product. If product failure occurs, corrective action shall be taken and samples resubmitted for qualification. Testing to confirm corrective action is required before resubmittal.

4.4. Quality Conformance Inspection

The applicable AMP quality inspection plan shall specify the sampling acceptable quality level to be used. Dimensional and functional requirements shall be in accordance with the applicable product drawing and this specification.

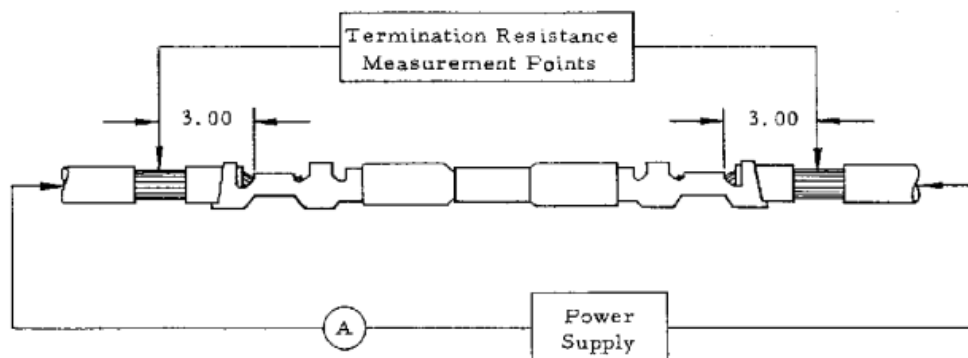
NOTE

Termination resistance equals millivolts divided by test current less resistance.

Figure 3
Termination Resistance Measurement Points

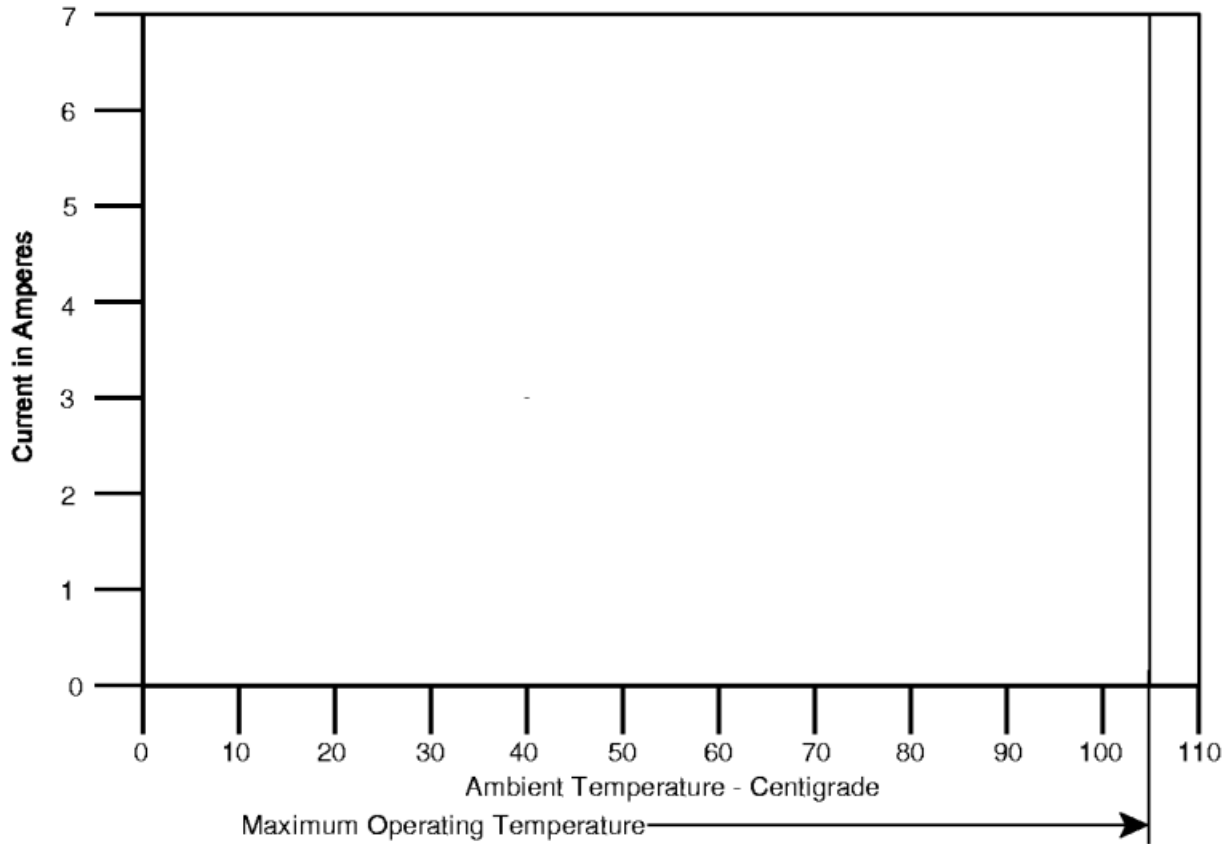

Figure 4A
Current Carrying Capability
4 Position Wire-To-Wire In-Line Connector

Percent Connector Loading 4 Position Wire-To-Wire In-Line Connector	Wire Size AWG		
	20	18	10
Single Contact	.5775	.6277	1.0
50	.5476	.5953	.9484
100	.4288	.4661	.7425

NOTE

To determine acceptable current carrying capacity for percentage connector loading and wire gage indicated, use the Multiplication Factor (F) from the above chart and multiply it times the Base rated Current for a single circuit at the maximum ambient operating temperature shown in Figure 4A.

Figure 4B
Current Rating
4 Position Wire-To-Wire In-Line Connector

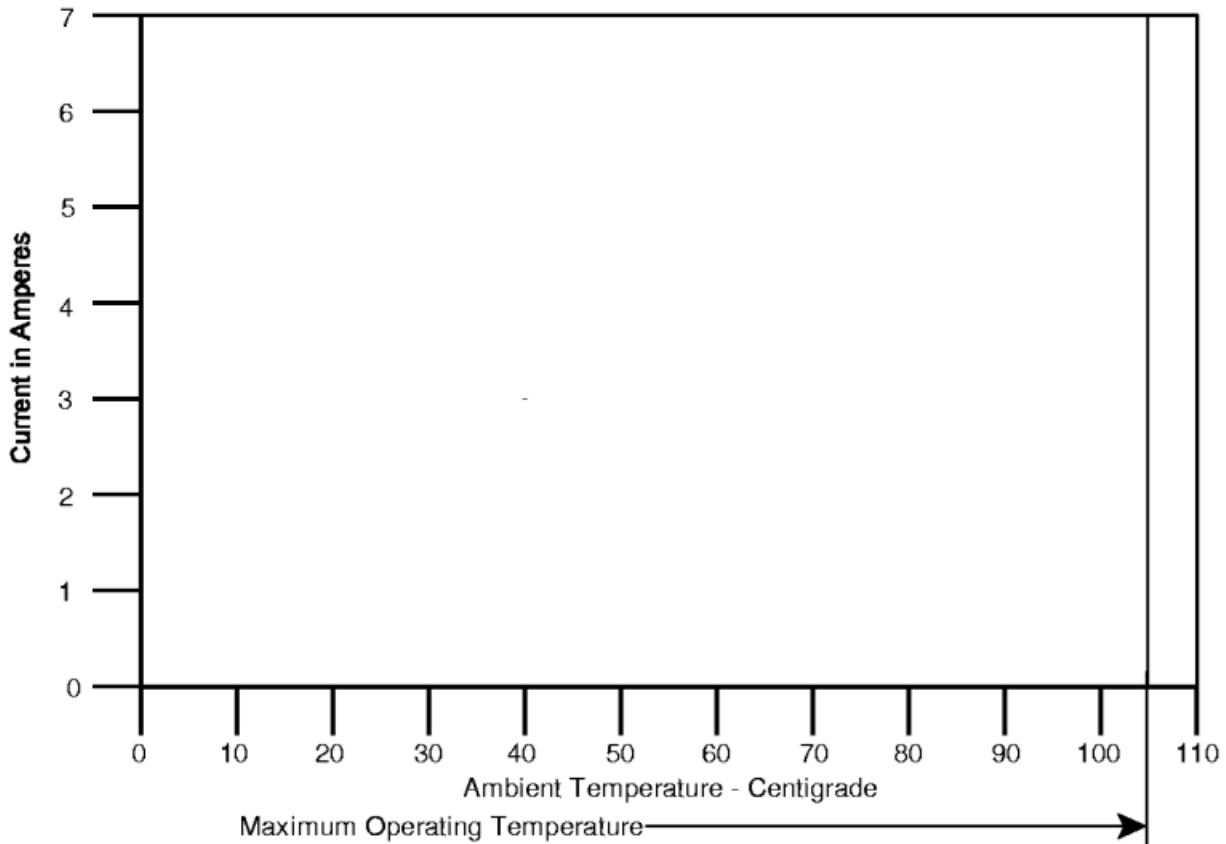

Figure 4C
Current Carrying Capability
12 Position Wire-To-Wire Matrix Connector

Percent Connector Loading 12 Position Wire-To-Wire Matrix Connector	Wire Size AWG		
	20	18	10
Single Contact	.5039	.5593	1.0
50	.3551	.3941	.7046
100	.2669	.2962	.5296

NOTE

To determine acceptable current carrying capacity for percentage connector loading and wire gage indicated, use the Multiplication Factor (F) from the above chart and multiply it times the Base rated Current for a single circuit at the maximum ambient operating temperature shown in Figure 4C.

Figure 4D
Current Rating
12 Position Wire-To-Wire Matrix Connector

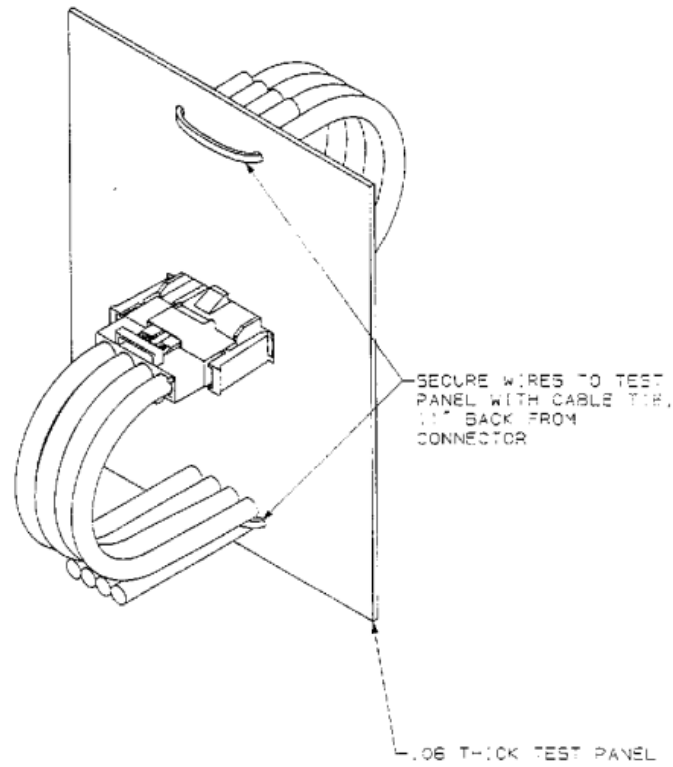

Figure 5A
Vibration & Mechanical Shock Mounting Fixture
Panel Mounted Samples

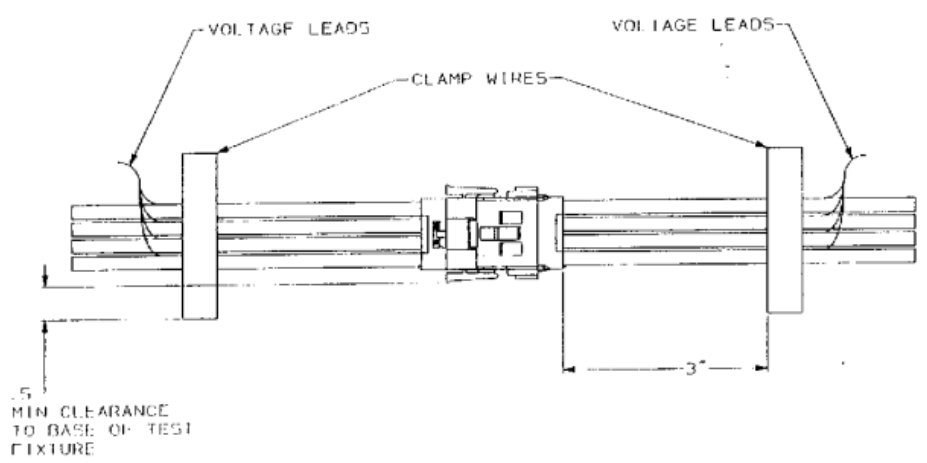

Figure 5B
Vibration & Mechanical Shock Mounting Fixture
Wire-To-Wire Samples