

4

3

2

1

THIS DRAWING IS UNPUBLISHED. RELEASED FOR PUBLICATION
 © COPYRIGHT - BY TYCO ELECTRONICS CORPORATION. ALL RIGHTS RESERVED.

LOC	DIST	REVISIONS			
P	LTR	DESCRIPTION	DATE	DWN	APVD
B		REV PER OH14-0582-04	9-12-05	TJB	FB

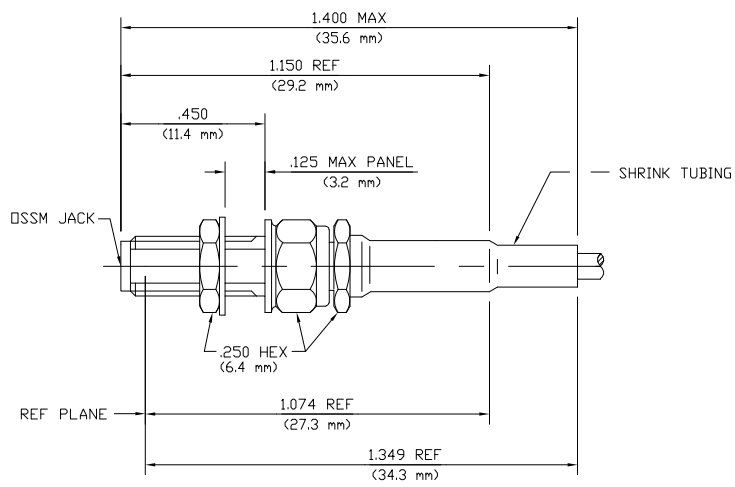

COMPONENT	MATERIAL	FINISH
HOUSING NUT	STAINLESS STEEL PER ASTM-A484 AND ASTM-A582, TYPE 303	GOLD PLATE PER MIL-G-45204 OVER NICKEL PLATE PER QQ-N-290LATE PER
CLAMP NUT		
LOCKWASHER		
DIELECTRIC	TFE FLUOROCARBON PER MIL-P-19468 AND FED SPEC L-P-403	N/A
CENTER CONTACT	BERYLLIUM COPPER PER QQ-C-530, ALLOY 173	GOLD PLATE PER MIL-G-45204 OVER COPPER PLATE PER MIL-C-14550
RETAINING RING	BERYLLIUM COPPER PER QQ-C-533	N/A
SLEEVE	BRASS PER QQ-B-626 COMP 360	GOLD PLATE PER MIL-G-45204 OVER COPPER PLATE PER MIL-C-14550
FERRULE	SOFT COPPER ALLOY	GOLD PLATE PER MIL-G-45204 OVER COPPER PLATE PER MIL-C-14550
SHRINK TUBING	HEAT SHRINKABLE POLYOLEFIN COMPOUND MIL-I-23053	N/A

CABLE ENTRY DIAMETER MINIMUM	
CONTACT	.023
SLEEVE	.0367
DIELECTRIC	.039

- DESIGNED FOR USE WITH RD 196 & RD 178 DOUBLE BRAIDED CABLE
- CAPTURED CENTER CONTACT
- VSWR 1.15+.030 F(GHZ)

1058596-1
 PART NUMBER

THIS DRAWING IS A CONTROLLED DOCUMENT.

DIMENSIONS: INCHES	TOLERANCES UNLESS OTHERWISE SPECIFIED:	DWN: TIM BLANCH 9-12-05	Tyco Electronics Corporation Harrisburg, Pa 17105-3608
	0 PLC ± - 1 PLC ± - 2 PLC ± .005 3 PLC ± - 4 PLC ± - ANGLES ± 1°	CHK: F. BLASICK 12-29-05 APVD: F. BLASICK 12-29-05	
MATERIAL: -	FINISH: -	NAME: OSM BULKHEAD FEED THRU CABLE JACK CRIMP ATTACHMENT SIZE: A3 CAGE CODE: 00779 DRAWING NO: 1058596	RESTRICTED TO: -
		WEIGHT: -	SCALE: 4:1 SHEET: 1 OF 1 REV: B

CUSTOMER DRAWING