

THIS DRAWING IS UNPUBLISHED. RELEASED FOR PUBLICATION .19
 © COPYRIGHT 19 BY AMP INCORPORATED. ALL RIGHTS RESERVED.

LOC DS
 DIST

REVISIONS

P	LTR	DESCRIPTION	DATE	DWN	APVD
0		RELEASED	6/22/'95	JW	BM
A		REVISED(FC00-0058-98)	13/AUG/'98	HS	CS
B		REVISED(FC00-0063-03)	09/MAY/'03	YD	CS

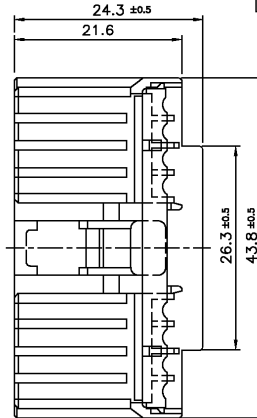
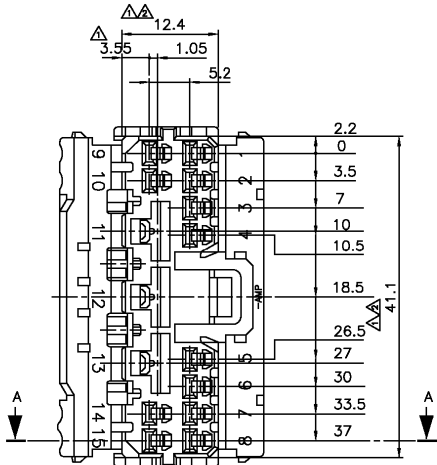

NOTE:

- ▲ TO BE MEASURED BETWEEN [A] AND 2
- ▲ TO BE MATE WITH TAP HSG SMOOTHLY
- 3 APPLIED RECEPTACLE CONTACT PART NUMBERS
 .070 SERIES: 173630, 173631
 .250 SERIES: 170032, 170258, 170384
- 4 APPLIED CAP HSG P/N : 85114
- ⓐ ▲ THESE ARE FOR LOCAL CUSTOMER WITH POLY BAG/MID BOX/OUT BOX.
- ⓑ ▲ THIS IS FOR EXPORT WITH TRAY/OUT BOX.

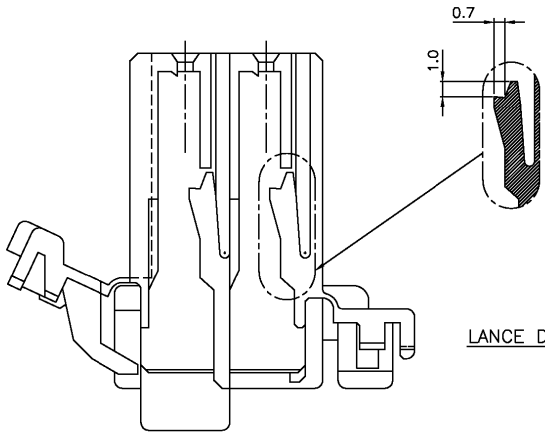

LANCE DETAIL

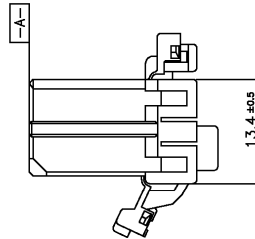

P/N	MATERIAL	COLOR	PACKING
1-85113-2	P.B.T	BLACK	▲ ⓐ
85113-5	P.B.T	BLUE	▲ ⓐ
85113-4	P.B.T	GREEN	▲ ⓐ
85113-2	P.B.T	BLACK	▲ ⓐ
85113-1	P.B.T	WHITE	▲ ⓐ

SECTION A-A

<p>THE DRAWING IS A CONTROLLED DOCUMENT FOR AMP INCORPORATED. IT IS SUBJECT TO CHANGE AND THE CONTROLLING ENGINEERING OPERATIONS SHOULD BE CONTACTED FOR THE LATEST REVISION.</p>		DWN YD. LEE CRK BM JANG	AMP KOREA. kyungsan, korea
<p>DIMENSIONS: MM</p>		APVD CS LEE	
<p>TOLERANCES UNLESS OTHERWISE SPECIFIED: 0-XX<10 ±0.2 10-XX<30 ±0.25 30-XX ±0.3 ANGLES ±3°</p>		NAME .070/.250 HYBRID 15P PLUG HSG	SIZE A3
<p>3rd ANGLE PROJECTION</p>		APPLICATION SPEC	
MATERIAL SEE TABLE		FINISH	DRAWING NO 8 5 1 1 3
		WEIGHT	SCALE 2/1
			SHEET 1 OF 1
			REV B