

PRODUCT SPECIFICATION

1. SCOPE

1.1. Content

This specification covers performance, tests and quality requirements for AMP* Metrimate pin and socket type connector equipped with Louvertac contact bands. Both pin and socket have wire barrels to receive solid or stranded copper wire. After placing stripped end of wire into the barrel, permanent attachment between the two is achieved via soldering or crimping with recommended tool. Louvertac contact bands fitted inside the socket provide a high current carrying medium with manageable insertion and extraction force. Pin and socket are available in three sizes to receive 8, 10 and 12/14 AWG wires. Connector body consists of two self-aligning halves. One half contains pins and the other contains sockets. Housing is designed for 8 independent channels. The two halves are polarized to preserve circuit polarity.

1.2. Qualification

When tests are performed on subject product line, procedures specified in AMP 109 series specifications shall be used. All inspections shall be performed using applicable inspection plan and product drawing.

2. APPLICABLE DOCUMENTS

The following documents form a part of this specification to the extent specified herein. Unless otherwise specified, latest edition of the document applies. In the event of conflict between requirements of this specification and product drawing, product drawing shall take precedence. In the event of conflict between requirements of this specification and referenced documents, this specification shall take precedence.

2.1. AMP Documents

- A. 109-1: General Requirements for Test Specifications
- B. 109 Series: Test Specifications as indicated in Figure 1. (Comply with MIL-STD-202, MIL-STD-1344 and EIA RS-364)
- C. Corporate Bulletin 401-76: Cross-reference between AMP Test Specifications and Military or Commercial Documents
- D. 501-229: Test Report

3. REQUIREMENTS

3.1. Design and Construction

Product shall be of design, construction and physical dimensions specified on the applicable product drawing.
*Trademark

COPYRIGHT 1984 BY AMP INCORPORATED ALL RIGHTS RESERVED.

<p>CONTROLLED DOCUMENT This specification is a controlled document per AMP Specification 102-21. It is subject to change and Corporate Standards should be contacted for latest revision.</p>				<p>DR B. Beckley 09 Nov 93</p>		<p>AMP AMP Incorporated Harrisburg, PA 17105-3608</p>		
				<p>CHK J. Jameel 12 Nov 93</p>				
				<p>APP R. Grebe 13 Nov 93</p>		<p>NO 108-1449</p>	<p>REV A</p>	<p>LOC B</p>
A	EC 94032802	<i>BBB</i>	<i>5/12/94</i>	<p>PAGE 1 OF 10</p>		<p>TITLE CONNECTOR, METRIMATE PIN & SOCKET WITH LOUVERTAC HIGH CURRENT CONTACTS</p>		
LTR	REVISION RECORD	APP	DATE					

3.2. Materials

- A. Housing: Polyester, glass filled, UL94V-0
- B. Louvertac contact band: Beryllium copper, gold plating
- C. Pin: Tellurium copper, gold over nickel plating
- D. Retaining ring: Phosphor bronze, nickel plating
- E. Socket: Tellurium copper, gold over nickel plating

3.3. Ratings

- A. Voltage: 250 vac
- B. Current: See Figure 2 for applicable current carrying capability
- C. Temperature: -55 to 125°C

3.4. Performance and Test Description

Product is designed to meet electrical, mechanical and environmental performance requirements specified in Figure 1. All tests are performed at ambient temperature unless otherwise specified.

3.5. Test Requirements and Procedures Summary

Test Description	Requirement	Procedure
Examination of product.	Meets requirements of product drawing.	Visual, dimensional and functional per applicable quality inspection plan.
ELECTRICAL		
Termination resistance, dry circuit.	1 milliohm maximum initial. 2 milliohms maximum final.	Subject mated contacts assembled in housing to 50 mv open circuit at 100 ma maximum. see Figure 5. AMP Spec 109-6-1.
Figure 1 (cont)		
Dielectric withstanding voltage.	1500 vac (rms) dielectric withstanding voltage. No breakdown or flashover.	Test DWV as follows: 1. Between adjacent contacts along length and width of mated connector assembly. 2. Between all pigtailed shorts together and metal foil wrapped around connector housing. AMP Spec 109-29-1.
Insulation resistance.	1000 megohms minimum.	Test between adjacent contacts of mated connector assembly and between shell and contacts. AMP Spec 109-28-4.

Figure 1 (cont)

Test Description	Requirement	Procedure
Temperature rise vs current.	30°C maximum temperature rise at specified current.	Measure temperature rise vs current. See Figures 2 and 7. AMP Spec 109-45-1.
MECHANICAL		
Vibration, sinusoidal high frequency.	No discontinuities greater than 1 microsecond. See Note (a).	Subject mated connectors to 10 G's between 10-500-10 Hz traversed in 15 minutes. 3 hours in each of 3 mutually perpendicular planes. See Figure 6. AMP Spec 109-21-1.
Physical shock.	No discontinuities greater than 1 microsecond. See Note (a).	Subject mated connectors to 50 G's half-sine shock pulses of 11 milliseconds duration. 3 shocks in each direction applied along 3 mutually perpendicular planes, 18 total shocks. See Figure 6. AMP Spec 109-26-1.
Mating force.	45 pounds maximum per connector.	Measure force necessary to mate connector assemblies from point of initial contact to full engagement using free floating fixtures at rate of 1 inch per minute. AMP Spec 109-42, Condition A.
Unmating force.	15 pounds minimum per connector.	Measure force necessary to unmate connector assemblies at rate of 1 inch per minute. AMP Spec 109-42, Condition A.
Contact retention, plug.	Contact socket shall not dislodge from housing.	Apply axial load of 10 pounds to contact socket wire in unmating direction at rate of .5 inch per minute. AMP Spec 109-30.

Figure 1 (cont)

Test Description	Requirement	Procedure								
Contact retention, receptacle.	Contact pin shall not dislodge from housing.	Apply axial load of 10 pounds to contact pin wire in unmating direction at rate of .5 inch per minute. AMP Spec 109-30.								
Crimp tensile, plug and receptacle contacts.	<table border="0"> <tr> <td>Wire Size</td> <td>Crimp Tensile</td> </tr> <tr> <td>AWG</td> <td>Pounds Minimum</td> </tr> <tr> <td>8/10</td> <td>160</td> </tr> <tr> <td>12/14</td> <td>55</td> </tr> </table>	Wire Size	Crimp Tensile	AWG	Pounds Minimum	8/10	160	12/14	55	Determine crimp tensile at rate of 1 inch per minute. AMP Spec 109-16.
Wire Size	Crimp Tensile									
AWG	Pounds Minimum									
8/10	160									
12/14	55									
Durability.	See Note (a).	Mate and unmate connector assemblies for 100 cycles at maximum rate of 600 cycles per hour. AMP Spec 109-27.								
Solderability, plug and receptacle contacts.	Solderable area, sleeve inside diameter, shall have minimum of 95% solder coverage.	Subject contacts to solderability. AMP Spec 109-11-1.								
ENVIRONMENTAL										
Thermal shock.	See Note (a).	Subject mated connectors to 25 cycles between -40 and 125°C. AMP Spec 109-22.								
Humidity-temperature cycling.	See Note (a).	Subject mated connectors to 10 humidity-temperature cycles between 25 and 65°C at 95% RH. AMP Spec 109-23-3, Condition B.								
Mixed flowing gas.	See Note (a).	Subject mated connectors to environmental class III for 20 days. AMP Spec 109-85-3.								
Temperature life.	See Note (a).	Subject mated connectors to temperature life at 161°C for 720 hours. AMP Spec 109-43.								

(a) Shall meet visual requirements, show no physical damage and shall meet requirements of additional tests as specified in test sequence in Figure 3.

Figure 1 (end)

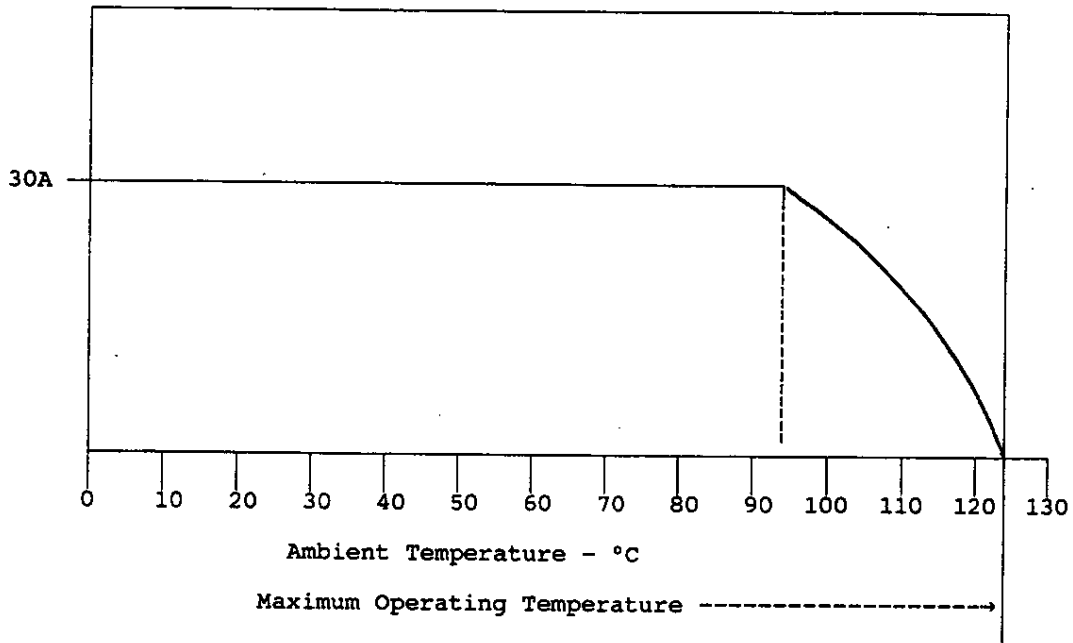

Note: Rated current per channel of an 8 channel connector assembly. All 8 channels fully energized. Pin and socket terminated to 8 AWG stranded wire by crimping.

Figure 2A
Current Carrying Capability

Wire Gage (AWG)	Crimped Termination
8	1.0
10	.92
12	.73
14	.58

Note: To determine acceptable current carrying capacity for other wire or termination configurations indicated, use Multiplication Factor (F) from above chart and multiply it times base rated current at maximum ambient operating temperature as shown in Figure 2A.

Figure 2B
Current Rating

3.6. Product Qualification and Requalification Test Sequence

Test or Examination	Test Group (a)				
	1	2	3(d)	4	5
	Test Sequence (b)				
Examination of product	1,11	1,9	1,8	1,3	1,3
Termination resistance, dry circuit	3,7	2,7			
Dielectric withstanding voltage			3,7		
Insulation resistance			2,6		
Temperature rise vs current		3,8			
Vibration	5	6(c)			
Physical shock	6				
Mating force	2				
Unmating force	8				
Contact retention, plug	9				
Contact retention, receptacle	10				
Crimp tensile				2	
Durability	4				
Solderability					2
Thermal shock			4		
Humidity-temperature cycling			5		
Mixed flowing gas		4(e)			
Temperature life		5			

- (a) See Para 4.1.A.
- (b) Numbers indicate sequence in which tests are performed.
- (c) Discontinuities shall not be measured. Energize at 18°C level for 100% loading as determined in AMP Specification 109-151.
- (d) Applies only to product with an insulating system.
- (e) Precondition samples with 10 cycles durability.

Figure 3

4. QUALITY ASSURANCE PROVISIONS

4.1. Qualification Testing

A. Sample Selection

Connector housings and contacts shall be prepared in accordance with applicable Instruction Sheets and shall be selected at random from current production. Quantity and description of test samples for each test group are shown in Figure 4. Samples for test groups 1 through 4 shall be prepared from stranded tinned copper wire of specified gage and length, insulated with high temperature silicone insulation rated at 200°C. Contacts (pins & sockets) shall be crimped to wire using Daniels Manufacturing Corp crimping tool model number M310 fitted with TP944 head. Contacts (pins and sockets) for test groups 1 and 2 shall be equipped with 2 inch long 30 AWG Teflon insulated probe wire crimped with power wire to facilitate termination resistance measurements. Unterminated ends of wires shall be stripped .75 inch long. Test group 5 samples shall consist of pins and sockets only.

Test Group	Sample Type	Sample Quantity	Contact PN		Power Wire		Probe Wire	
			Pin	Socket	AWG	Length (inch)	AWG	Length (inch)
1	(a)	4	193457-1	193458-1	8	18	30	2
		4	193534-1	193535-1	14	18	30	2
2	(a)	4	193457-1	193458-1	8	18	30	2
		4	193534-1	193535-1	14	18	30	2
3	(a)	4	193457-1	193458-1	8	12		
		4	193534-1	193535-1	14	12		
4	(b)	4	193457-1		8	9		
		4		193458-1	8	9		
		4	193534-1		14	9		
		4		193535-1	14	9		
5	(c)	4	193457-1	193458-1				
		4	193534-1	193535-1				

- Note: (a) Unmated plug and receptacle housings fully equipped with contacts (pins and sockets) terminated to wires of specified gage and length.
 (b) Contacts (pins and sockets) terminated to wires of specified gage and length. Housings shall not be supplied.
 (c) Loose contacts (pins and sockets). Wires or housings shall not be supplied.

Figure 4

B. Test Sequence

Qualification inspection shall be verified by testing samples as specified in Figure 3.

4.2. Requalification Testing

If changes significantly affecting form, fit or function are made to product or to the manufacturing process, product assurance shall coordinate requalification testing consisting of all or part of original testing sequence as determined by development/product, quality and reliability engineering.

4.3. Acceptance

Acceptance is based on verification that product meets requirements of Figure 1. Failures attributed to equipment, test setup or operator deficiencies shall not disqualify product. When product failure occurs, corrective action shall be taken and samples resubmitted for qualification. Testing to confirm corrective action is required before resubmittal.

4.4. Quality Conformance Inspection

Applicable AMP quality inspection plan will specify sampling acceptable quality level to be used. Dimensional and functional requirements shall be in accordance with applicable product drawing and this specification.

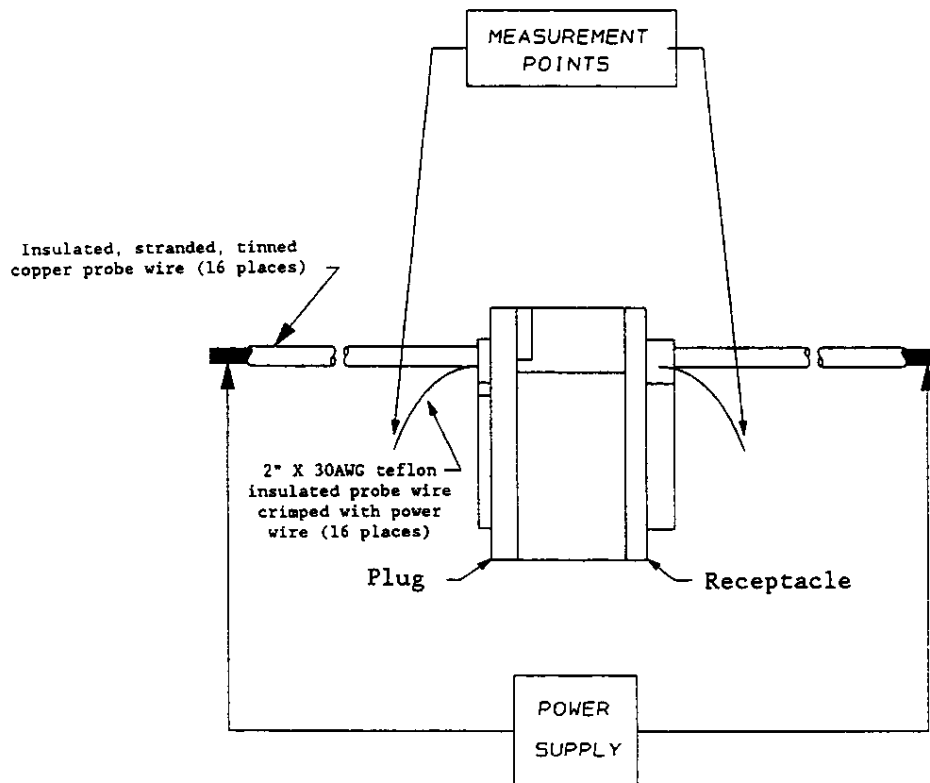

Figure 5
Termination Resistance Measurement Points

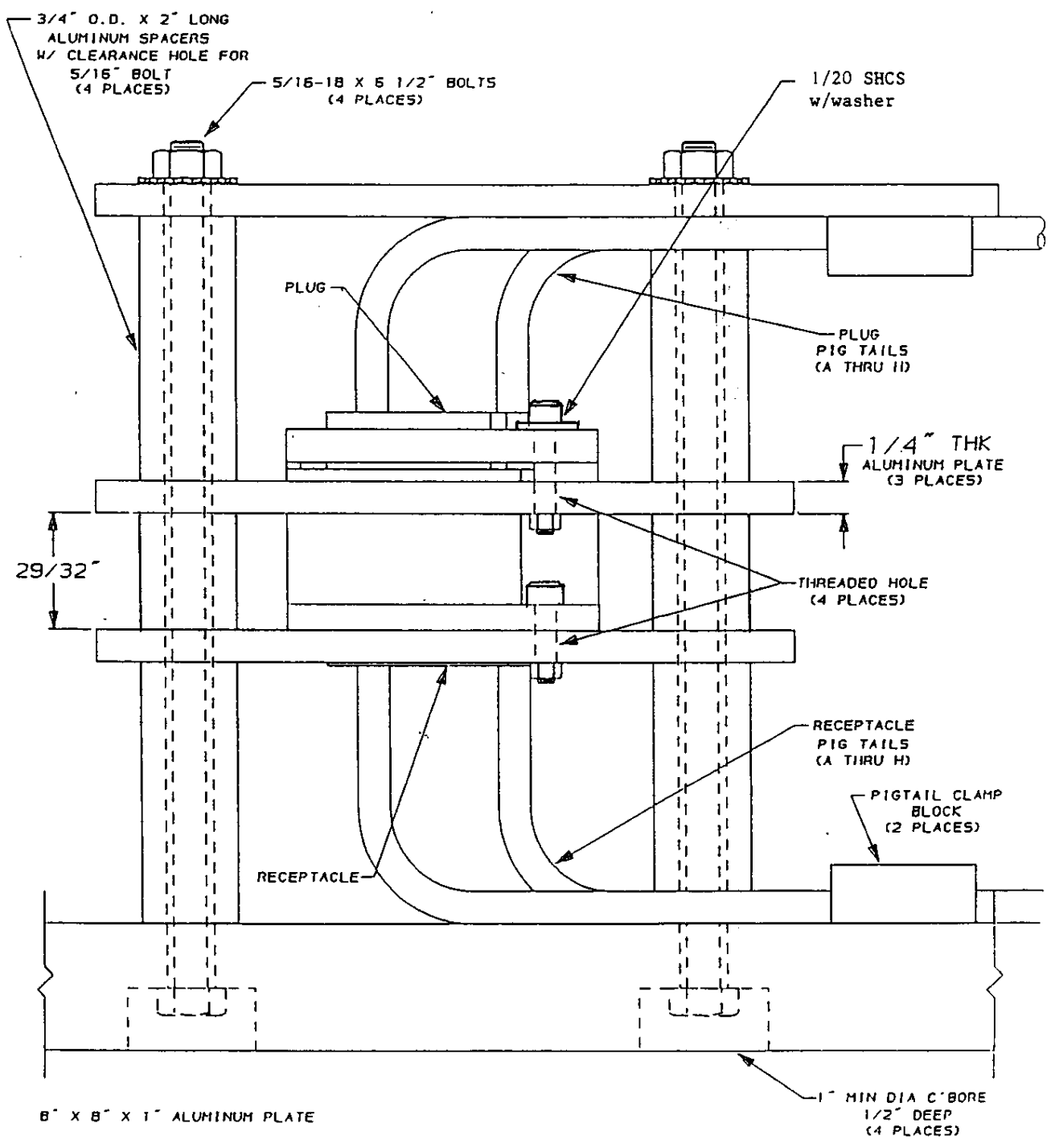
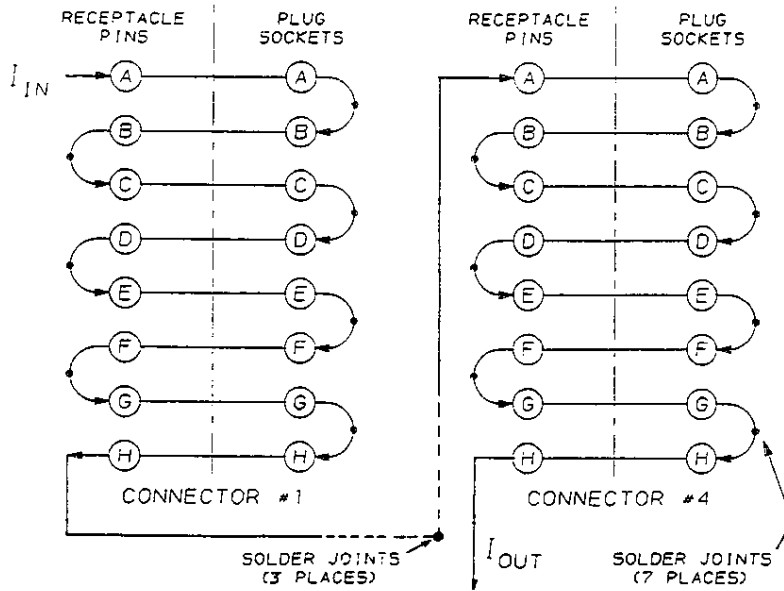

Figure 6
Vibration & Physical Shock Fixture



HOOK-UP CONFIGURATION FOR T-RISE

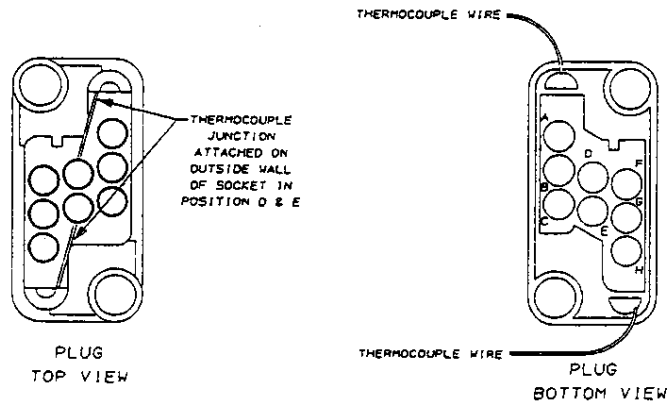

Figure 7
Temperature Rise vs Current