

4

3

2

1

THIS DRAWING IS UNPUBLISHED. RELEASED FOR PUBLICATION
 © COPYRIGHT - BY TYCO ELECTRONICS CORPORATION. ALL RIGHTS RESERVED.

LOC	DIST	REVISIONS					
GP	00	P	LTR	DESCRIPTION	DATE	DWN	APVD
		A		RELEASED	31MAR06	RG	SF

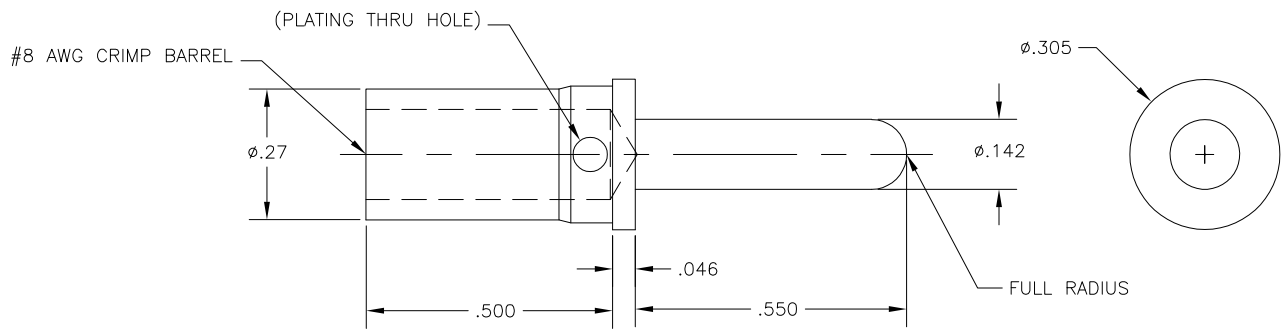

5. REFERENCE ELCON SERIES 701-11-02107
4. FINISH: SILVER PLATED .0002 MIN THK.
OVER NICKEL .00004 MIN THK.
3. MATERIAL: COPPER ALLOY
2. ITEMS PROVIDED TO THIS SPECIFICATION SHALL BE IDENTIFIED ON THE CONTAINER WITH THE FOLLOWING INFORMATION: PART NUMBER & DATE CODE OF MFR.
1. PART NUMBER CHANGES AND/OR DESIGN CHANGES AFFECTING ITEM INTERCHANGEABILITY REQUIRE PRIOR ELCON APPROVAL AND AUTHORIZATION BY REVISION TO THIS DRAWING.

1766192-1
PART NUMBER

THIS DRAWING IS A CONTROLLED DOCUMENT.		DWN	R.GRZYBOWSKI	31MAR06	Tyco Electronics Corporation Harrisburg, PA 17105-3608	
DIMENSIONS: INCHES		CHK	S.FLICKINGER	31MAR06	NAME	
TOLERANCES UNLESS OTHERWISE SPECIFIED:		APVD	S.FLICKINGER	31MAR06	CONTACT, PIN, SIZE #8, CRIMP STANDARD, .43 PIN EXT.	
0 PLC ± -		PRODUCT SPEC	-			
1 PLC ± -		APPLICATION SPEC	-			
2 PLC ± .02		WEIGHT	-			
3 PLC ± .010		SIZE	A3	CAGE CODE	00779	DRAWING NO
4 PLC ± - .5		FINISH	-		1766192	RESTRICTED TO
MATERIAL		ANGLE	-		SCALE	5:1
SEE NOTE 3		CUSTOMER DRAWING	SHEET		1 OF 1	REV
						A