

REV	DATE	DESCRIPTION	BY	CHK	APP
DF	AO				
B		REV PER ECO 05-07599			RG

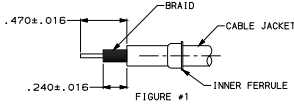

1. CABLE PREPARATION:
- SLIDE INNER FERRULE ONTO CABLE MAKING SURE TO KEEP THE LARGER DIAMETER OF INNER FERRULE OPPOSITE FROM THE END OF THE CABLE BEING TERMINATED. (SEE FIGURE #1)
  - STRIP OUTER JACKET AND BRAID AS INDICATED IN FIGURE #1. CARE SHOULD BE TAKEN NOT TO NICK OR CUT THE BRAID STRANDS DURING THE REMOVAL OF THE JACKET.
  - EVENLY FLARE THE BRAID BACK OVER THE OUTER JACKET AND CUT CENTER CONDUCTOR & DIELECTRIC WITHIN THE LIMITS INDICATED IN FIGURE #2.
- (1) CARE SHOULD BE TAKEN NOT TO NICK OR CUT INDIVIDUAL CONDUCTORS DURING REMOVAL OF DIELECTRIC.  
 (2) INDIVIDUAL CONDUCTORS SHOULD BE TWISTED TIGHTLY TO ELIMINATE LOOSE WIRE STRANDS.

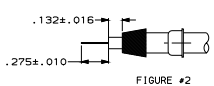

SCALE 2:1

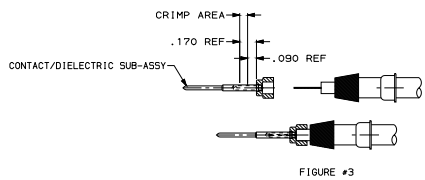

2. CRIMPING:
- CENTER CONDUCTOR- CRIMP CENTER CONDUCTOR USING DANIELS MFG CORP 4-B INDENT HANDTOOL M22520/2-01. THE HANDTOOL CRIMP SELECTOR SHOULD BE SET TO #5. NO LOCATOR IS NECESSARY. INSERT THE CONTACT/DIELECTRIC SUB-ASSEMBLY INTO HANDTOOL. THE DIELECTRIC WILL POSITION THE CENTER CONTACT. INSERT THE CENTER CONDUCTOR INTO CONTACT WIRE BARREL. THE TIP OF THE STRIPPED WIRE SHOULD BE VISIBLE IN THE WIRE BARREL SIGHT HOLE. CRIMP AND REMOVE CENTER CONTACT. SEE FIGURE #3.
  - INSERT THE CRIMPED CENTER CONTACT AND CABLE INTO OUTER CONTACT BODY. SLIDE FERRULE INTO OUTER CONTACT BODY CAPTURING TRIMMED BRAID BETWEEN FERRULE AND SHELL BODY.
  - FERRULE CRIMP- PLACE CONTACT ASSEMBLY INTO AMP HAND CRIMPING TOOL 354840-1 AND DIE SET 91307-1 AND BOTTOM BRAID BETWEEN FERRULE AND SHELL BODY. CRIMPING AND RELEASE CONTACT. SEE FIGURE #4.
  - AFTER CRIMPING, THE DIAMETER ACROSS THE .200 DIMENSION, SHOWN IN FIGURE #4 SHOULD BE .273-.276.

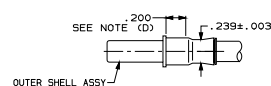

SCALE 2:1

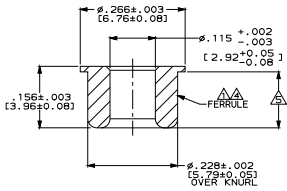
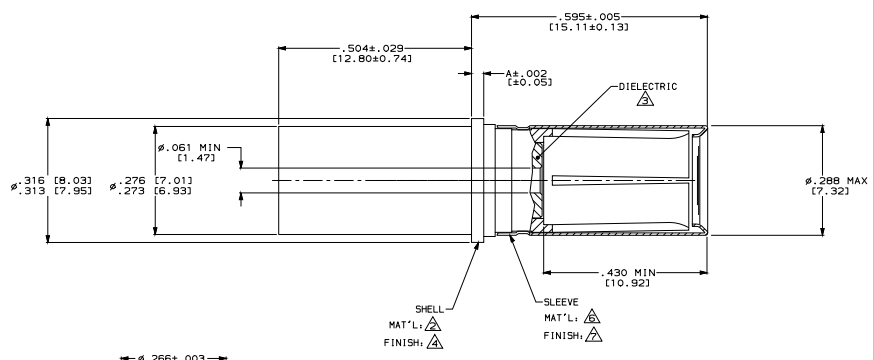
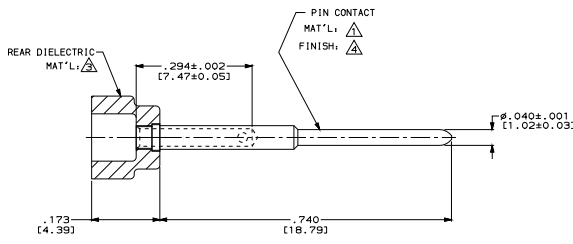

- △ MAT'L: BRASS PER ASTM-B-16
- △ MAT'L: BERYLLIUM COPPER PER ASTM-B-196.
- △ MAT'L: PTFE PER ASTM-D-1710.
- △ FINISH: GOLD PLATE PER MIL-G-45204, TYPE 1, GRADE C, CLASS 1 OVER NICKEL .000050 (0.0013) THK PER QQ-N-290, CLASS 2.
- △ 160 DP. FULL DIAMOND KNURL OVER THIS LENGTH.
- △ MAT'L: STAINLESS STEEL PER QQ-S-766.
- △ FINISH: PASSIVATE PER QQ-P-35.

USED IN HIRF 1202 INSERT	RG-316	TBD	1218820-2
	RG-316	.031 (0.79)	1218820-1
REMARKS	CABLE	DIM A	PART NUMBER
THIS DRAWING IS A CONTROLLED DOCUMENT. (P. C. THOMAS) (11/79)			
DESIGNED BY	INSTRUMENTS/ENGRS.	REVISIONS	DATE
INCHES (mm)	BY: [Signature]	BY: [Signature]	BY: [Signature]
DATE: 09.10.80	DATE: 09.10.80	DATE: 09.10.80	DATE: 09.10.80
SEE CALLOUTS	SEE CALLOUTS	CUSTOMER DRAWING	SIZE: 8.1

**AMP** AMP Incorporated  
 Harrisburg, PA 17105-3608

**COAX SOCKET CONTACT ASSY**  
 REAR RELEASE, SIZE B

SIZE: 8.1 PART: 1 REV: B