

4

3

2

1

THIS DRAWING IS UNPUBLISHED. RELEASED FOR PUBLICATION - N/A.
 COPYRIGHT N/A BY TYCO ELECTRONICS CORPORATION. ALL RIGHTS RESERVED.

DESIGNED TO USE BMS13-65-OF CABLE	
JACKET O.D.:	.141
DIA OVER DIELECTRIC:	.123
INNER CONDUCTOR O.D.:	.034

REV	DESCRIPTION	DATE	BY	APP'D
D	REV PER ECO-07-0005776	04APR07	PY	RG

- 1 MAT'L: BRASS PER ASTM-B-16
- 2 MAT'L: BERYLLIUM COPPER PER ASTM-B-196.
- 3 MAT'L: PTFE PER ASTM-D-1710.
- 4 FINISH: GOLD PLATE PER MIL-G-45204, TYPE 1, GRADE C, CLASS 1 OVER NICKEL .000050 THK PER QQ-N-290, CLASS 2.
- 5 160 DP. FULL DIAMOND KNURL OVER THIS LENGTH.
- 6 SILICONE RUBBER PER ZZ-R-765.

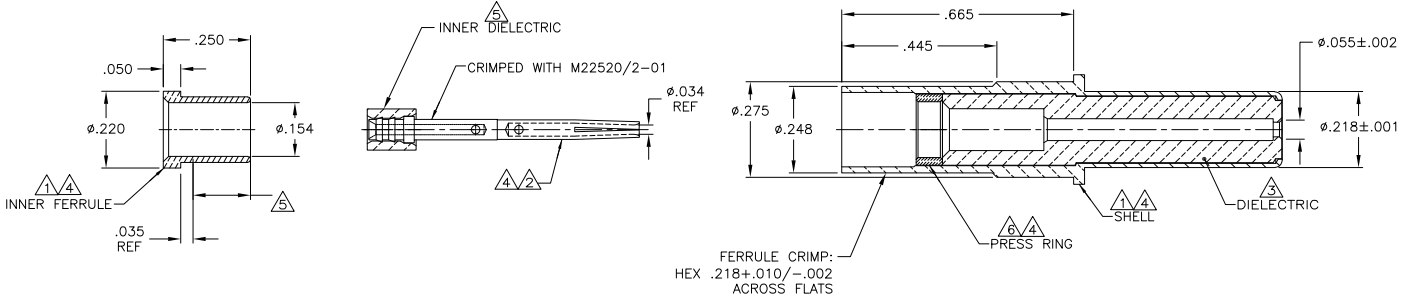

ASSEMBLY PROCEDURE:

1. STRIP OUTER INSULATION BACK FROM CABLE .600 INCH.
2. SLIGHTLY FLARE THE SHIELD AND TRIM APPROX. .25 INCH OF THE DIELECTRIC, CENTER CONDUCTOR AND FILLER.
3. SLIDE FERRULE OVER STRIPPED END OF CABLE UNTIL KNURLED END IS EVEN WITH CABLE JACKET.
4. COMB OUT SHIELD, FOLD SHIELD BACK OVER THE KNURLED PORTION OF THE FERRULE. TRIM THE SHIELD EVEN WITH THE BOTTOM OF THE FERRULE CAP.
5. TRIM THE DIELECTRIC APPROX. .550 INCH FROM THE END OF THE FOLDED BACK SHIELD.
6. TRIM THE CENTER CONDUCTOR .330 INCH FROM THE END OF THE DIELECTRIC.
7. INSERT THE CENTER CONDUCTOR INTO THE CENTER CONTACT SUB-ASSY UNTIL THE CABLE DIELECTRIC BOTTOMS AGAINST THE CONTACT DIELECTRIC. CRIMP THE CENTER CONDUCTOR USING A M22520/2-01 CRIMP TOOL SET AT SELECTOR SWITCH POSITION #5. IT IS EASIER TO LOCATE CRIMP BY PARTIALLY CLOSING THE CRIMP TEETH UNTIL THE CONTACT DIELECTRIC RESTS AGAINST THE TEETH AND THEN COMPLETE CRIMP.
8. SLIDE CRIMPED CENTER CONTACT SUB-ASSEMBLY INTO BODY HOUSING AND SEAT FERRULE. CRIMP FERRULE USING AN M22520/5-01 HANDTOOL AND DIE SET M22520/5-45 OR EQUIVALENT (.218 HEX CRIMP) CENTERING CRIMP BETWEEN FERRULE CAP AND .275 DIAMETER OF CONTACT. (.445 LENGTH SHOWN ABOVE)

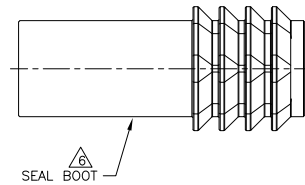

1757624-1
PART NUMBER

THIS DRAWING IS A CONTROLLED DOCUMENT.		DR: C.C. THOMAS 07JAN2005	Tyco Electronics Corporation Harrisburg, Pa 17105-3608	
DIMENSIONS: INCHES		CHK: 1-7-05	CONTACT ASSY, SIZE 8, ARINC-COAX	
OTHER DIMENSIONS UNLESS OTHERWISE SPECIFIED:		APP'D: 1-7-05	RESTRICTED TO	
MATERIAL: SEE CALLOUTS		FINISH: SEE CALLOUTS	SIZE: A2	CHG CODE: 00779
DRAWING NO: 1757624		SCALE: 5:1		SHEET: 1 OF 1
CUSTOMER DRAWING		REV: D		

AMP 1471-9 REV 31MM2000

1757624

A