

4

3

2

1

THIS DRAWING IS UNPUBLISHED.		RELEASED FOR PUBLICATION		LOC		DIST		REVISIONS						
© COPYRIGHT 19		BY AMP INCORPORATED. ALL RIGHTS RESERVED.		G		86		P LTR		DESCRIPTION		DATE	DWN	APVD
								A		REL PER 063A-0023-02		24APR02	JR	CK

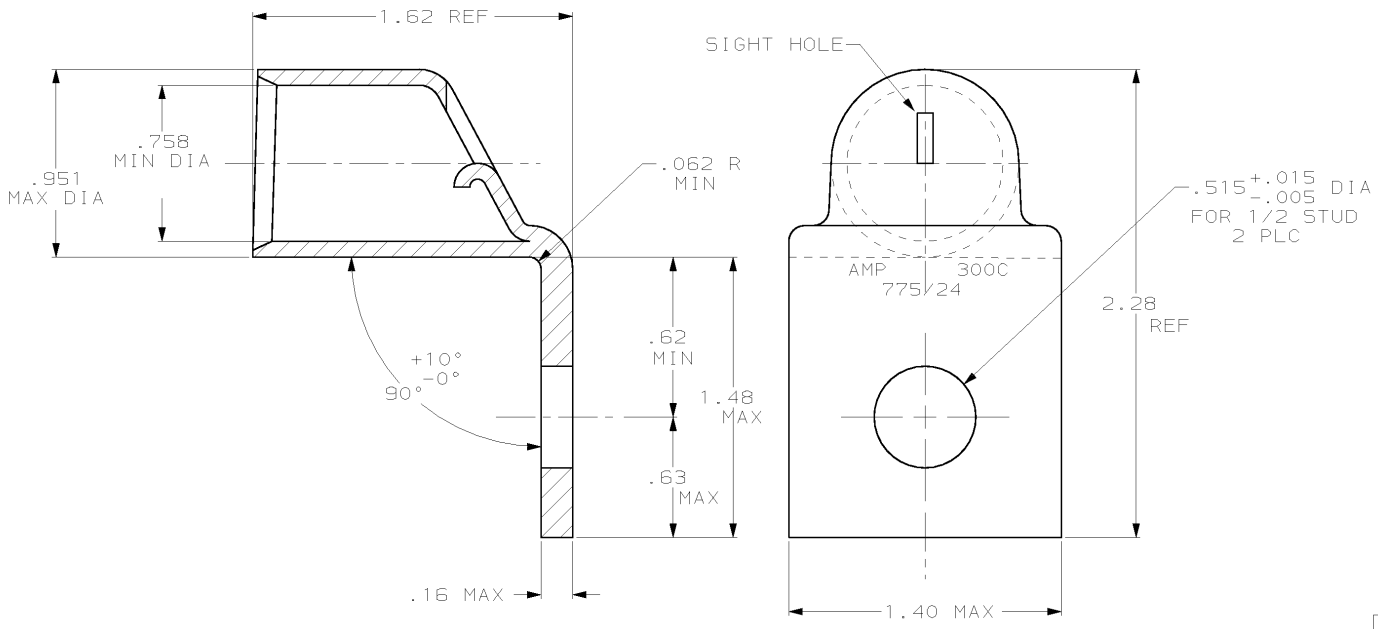

696391-1
AMP
PART NUMBER

AMP INCORPORATED CUSTOMER SERVICE SYSTEMS			<small>THIS DRAWING IS A CONTROLLED DOCUMENT FOR AMP INCORPORATED. IT IS SUBJECT TO CHANGE AND THE CONTROLLING ENGINEERING ORGANIZATION SHOULD BE CONTACTED FOR THE LATEST REVISION.</small>		DWN JR RUTH 14DEC01 CHK YR SPICER 14DEC01 APVD M SPICER 14DEC01		AMP AMP Incorporated Harrisburg, PA 17105-3608	
			DIMENSIONS: mm (INCHES)		TOLERANCES UNLESS OTHERWISE SPECIFIED: 0 PLC ±. 1 PLC ±. 2 PLC ±. 3 PLC ±. 4 PLC ±. ANGLES ±.		NAME TERMINAL, AMPPOWER, BENT 90 WIRE SIZE: 300 MCM	
FOR ADDITIONAL PRODUCT INFORMATION OR COPIES OF DRAWINGS AND TECHNICAL DOCUMENTS	PRODUCT INFORMATION CENTER 1-800-522-6752	RECOMMENDED OPERATING TEMPERATURE: 170° MAX	VOLTAGE RATING: NOT APPLICABLE		MATERIAL COPPER PER ASTM B-188 ANNEALED	FINISH TIN PLATE 0.00381 L-000150J MIN THK	WEIGHT .142 lbs	SIZE A3 CAGE CODE 00779 DRAWING NO. 696391
FOR APPLICATION TOOLING INFORMATION	TOOLING ASSISTANCE CENTER 1-800-722-1111	WIRE CROSS SECTIONAL AREA RANGE: 100.0-125.0mm² (190,000-231,000 CIR MILS) SOLID OR STRANDED						SCALE 2:1 SHEET 1 OF 1 REV A
FOR ORDER ENTRY	1-800-526-5142							

AMP 1470-19 REV 09MAY94
 14-DEC-01 13:54:43 amp13469 /ws/tesp/u.jr-proposals