

This specification is the English language version of 108-5793
In the event of conflict, 108-5793 shall take precedence.

1. Scope:

1.1 Contents

This specification covers the requirements for product performance test methods and quality assurance provisions of Sealed MQS/JPT 81P/40P Slide Lever Type Connectors. Applicable product description and part numbers are as shown in Appendix 1.

2. Applicable Documents:

The following documents from a part of this specification to the extent specified herein. In the event of conflict between the requirements of this specification and the product drawing, the product drawing shall take precedence. In the event of conflict between the requirements of this specification and the referenced documents, this specification shall take precedence.

2.1 AMP Specifications:

- A. 109-5000 : Test Specification, General Requirements for Test Methods
- B. 114-18021 : Application Specification MQS Receptacle Contact
114-18050-1 : Application Specification JPT Receptacle Contact
- C. 501-5437 : Examination Report
- D. 411-78008 : Instruction Sheet

2.2 Commercial Standards and Specifications:

- A. JASO D605: Multi-pole Connector for automobiles
- B. JASO D7101: Test Methods for Plastic Molded Parts
- C. JIS C3406 : Low-Voltage Wires and Cables for Automobiles
- D. JIS D0203: Method of Moisture, Rain and Spray Test for Automobile Parts
- E. JIS D0204: Method of High and Low Temperature Test for Automobiles Parts
- F. JIS D1601: Vibration Testing Method for Automobile Parts

3. Requirements:

3.1 Design and Construction:

Product shall be of the design, construction and physical dimensions specified on the applicable product drawing.

3.2 Material:

A. Contact:

| Description | Material | Finish |
|---------------------|-------------------|--------|
| Tab (Male) | Phosphorus-bronze | Tin |
| Receptacle (Female) | Copper alloy | Tin |

Fig.1

B. Housing:

- a. Front Cavity Block 40P : PA66
- b. Front Cavity Block 81P : PA66
- c. Main Cavity Block 40P : PBT
- d. Main Cavity Block 81P : PBT
- e. Seal Retainer 40P : PBT
- f. Seal Retainer 81P : PBT
- g. Slider 40P : PA66
- h. Slider 81P : PA66
- i. JPT Retainer : PBT
- j. Family Seal 32P : SILICONE
- k. Family Seal 76P : SILICONE
- l. Seal Ring 40P : SILICONE
- m. Seal Ring 81P : SILICONE

C. And others:

- a. Wire Cover 40P : PBT
- b. Wire Cover 81P(A) : PBT
- c. Wire Cover 81P(B) : PBT
- d. Lever 40P : PBT
- e. Lever 81P : PBT
- f. MQS Retainer 40P : PBT
- g. MQS Retainer 81P : PBT
- h. Cavity•Plug for MQS: PBT
- i.Cavity•Plug for JPT : SILICONE
- j.Wire Seal for JPT : SILICONE

3.3 Ratings:

A. Temperature Rating: -40°C ~ 120°C

3.4 Performance Requirements and Test Descriptions:

The product shall be designed to meet the electrical, mechanical and environmental performance requirements specified in Fig.2.All tests shall be performed in the room temperature, unless otherwise specified.

3.5 Test Requirements and procedures Summary:

| Para. | Test Items | Requirements | Procedures |
|-------------------------|--|--|--|
| 3.5.1 | Confirmation of Product | Meet requirements of product drawing and AMP Specifications | Visually, dimensionally and functionally inspected per applicable quality inspection plan. |
| Electrical Requirements | | | |
| 3.5.2 | Termination Resistance (Low Level) | MQS: 30mΩ Max.(Initial) 30mΩ Max.(Final) | Mated contacts assembled in housing with 20mV max. of open-voltage and 10mA max. of short-circuit current. See Fig.3 |
| | | JPT: 10mΩ Max. (Initial) 10mΩ Max. (Final) | |
| 3.5.3 | Termination Resistance (Specified Current) | MQS 10mV/A Max. (Initial) 30mV/A Max. (Final) | Mated contacts assembled in housing with 13V of open-voltage and 1A of short-circuit. See Fig.3 |
| | | JPT 3 mV/A Max. (Initial) 10 mV/A Max. (Final) | |
| 3.5.4 | Insulation Resistance | 250MΩ Min. (Initial) | Impressed voltage 500V DC. Mated connector. As shown in Fig.4 |
| 3.5.5 | Voltage Resistance | No cracking, damage, bending, thin coating coming off or rust is allowed in a terminal. No kink like a crack, solution, backlash and parts coming off or etc. is allowed in housing. | Impressed voltage 1kV AC for 1min. Mated connector. See Fig. 4 |
| 3.5.6 | Current Leakage | 1 μA Max. (Initial) 10 μA Max. (Final) | After leaving the contact in a constant temperature of 60±5°C and humidity 90~95% for 1hour, impressed voltage 13V DC between the terminals. See Fig.5 |

Fig.2(To be continued)

| Para. | Test Items | Requirements | Procedures |
|------------------------------|--------------------------|--|--|
| 3.5.7 | Temperature Rising | Under loaded specified current MQS 25°C Max. (Initial) 30°C Max. (Final) JPT 35°C Max. (Initial) 40°C Max. (Final) | Measure temperature rising by engaged current: Current value wire size MQS: 3A 0.5sq JPT: 10A 1.25sq Current applied to every other position. See Fig.6 |
| 3.5.8 | Fuse Matching Character | No melting of housing or no ignition of connector is permitted. Discoloration on housing and cable is possible. | To be applied current i1 for 24hours. Next, i2 current should be applied for 1hour. However, the i1, i2 and wire size should be followed by the below. Atmosphere temperature should be 60°C. i1 i2 wire size MQS: 11A 14A 0.5sq JPT: 22A 27A 1.25sq |
| 3.5.9 | Current Cycle Resistance | Termination Resistance (Low Level): MQS 30mΩ Max. JPT 10mΩ Max. Termination Resistance (Specified Current): MQS 30 mV/A Max. JPT 10 mV/A Max. | Connect the pattern (shown in Fig.6) in series and apply current for 300 cycles in the atmosphere. Each cycle is 45min-ON,15min-OFF Current value wire size MQS: 3A 0.5sq JPT: 10A 1.25sq |
| Physical Requirements | | | |
| 3.5.10 | Contact Retention Force | (MQS) Lance only: 20N Max. Secondary lock set: 98N Max. | Apply the pull-off load of the contact to axial. Operation speed: 200 mm/min. |
| | | (JPT) Lance only: 59N Max. Secondary lock set: 98N Max. | |
| 3.5.11 | Locking Strength | To be 98N or more. When applying a load of 98N, confirm by the electric continuity that each terminal is perfectly connected to each other. | Engaging plug/cap housing assembled with harness, in status where the lever is completely connected, and pull the harness to directions (Fig.7). Measure the load values depending on the connector breaking and the lever breaking. Operation Speed: 20mm/min. |
| 3.5.12 | Cover Holding Force | Lengthwise: 60N Max. Crosswise: 90N Max. | In status where the cover is assembled on male/female connector, apply a load to the cable outlet portion and measure the load value when the cover damaged or the cover losing occurs. |

Fig.2(To be continued)

| Para. | Test Items | Requirements | Procedures |
|--------|--|--------------|---|
| 3.5.13 | Lever Operating Force | 60N Max. | When engaging male/female connector provided with all contact terminals by using a lever, measure the following load:(I) Necessary load till the lever is completely connected (position A) from the lever temporary connected position (position B the pre-setting is released status). (ii) Necessary load till the lever is temporarily connected (position A) in the temporary status from the lever completed connection (position B this setting is in the released status) See Fig.8 |
| 3.5.14 | Lever Pre-setting Holding Force (Primary Lock) | 10N Min. | When turning the lever in to the engaging direction from the status where the lever is held in the pre-setting(position A), measure the necessary load to release the lever pre-setting. See Fig.8 |
| 3.5.15 | Lever Complete Setting Force | 78N Min. | When turning the lever in to the releasing direction from the status where the lever is held in the complete setting (position B), measure the necessary load to release the lever complete setting. See Fig.8 |
| 3.5.16 | Lever Pre-Setting Force | 50N Max. | Measure the necessary loads to release the complete setting and the pre-setting of the lever. |
| 3.5.17 | Excessive Rotation Strength | 98N Min. | With status where the lever is assembled on connector not being engaged, measure the load when the housing damage or loosing from the fulcrum occurs by applying the reversal directional load against the lever rotating direction from the lever rotation stop position (the rotation start/final position). See Fig.9 |

Fig.2(To be continued)

| Para. | Test Items | Requirements | Procedures |
|--------|--|--|--|
| 3.5.18 | Lever Fulcrum Strength | 200N Min. | Pulling the lever from status where the lever is assembled to connector not being engaged, measure the load when the lever is ran out or broken. See Fig.10 |
| 3.5.19 | Side Load Lever Operation | 98N No falling or damage of the lever is permitted | By applying a load to the vertical direction against the lever rotation direction from the lever inside at atmosphere temp.35°C, Engage the lever the mating connector by turning the lever terminal section. See Fig.11 |
| 3.5.20 | Worst Connction | All terminals should be made contact without abnormal deformation in each position | Temporarily set cap/plug housing assembled with harness, apply a tension of 80N to direction (up, down. Left and right) for harness and perform connector engaging by the lever. See Fig.12 |
| 3.5.21 | Decay Resistance (Insert and Separate Repeating) | Termination Resistance(Low Level): MQS 30mΩMax. JPT 10mΩMax. Termination Resistance (Specified Current): MQS 30mV/A Max. JPT 10mV/A Max. | One side of a pair of connectors is fixed, another side is repeated in the direction of an axis, and insertion secession is performed 20times. |
| 3.5.22 | Prige Resistance | Termination Resistance (Low Level): MQS 30mΩMax. JPT 10mΩMax. Termination Resistance (Specified Current): MQS 30mV/A Max. JPT 10mV/A Max. | With connector in a fixed position apply “kajiri “around the front edge by 78N force inserting the other in axial and right angle. (Direction: backwards and forwards, right and left.)Pull it out after applying “kajiri” with 2 steps (the 1 st step being the terminals contact and the 2 nd step is when the maximum mating occurs). Repeat this cycle 5times. See Fig.15 |

Fig.2(To be continued)

| Para. | Test Items | Requirements | Procedures |
|--------|--------------------------------|--|---|
| 3.5.23 | Vibration (High Frequency) | During the vibration, the instantaneous break down of max.1V voltage drop should not be continued 10μsec or more. Termination Resistance (Low Level), Termination Resistance (Specified Current): Same as 3.5.21 Temperature Rise: MQS 30°C Max. JPT 40°C Max. | Vibration Frequency : 10~50Hz/8 min. Accelerated Velocity : 66.6m/s ² (6.8G) Vibration Direction : , up and down, back to front, light and left Duration: up and down for 4hours: 100 μ A back to front for 2hours: } MQS 3A light and left for 2hours: } JPT 10A See Fig.13. Turn on electricity to the pattern shown in Fig.6 |
| 3.5.24 | Drop and Impact Resistance | Drop from the following height and to be free from harmful breakage and part loosening. 40P : 0.8m 81P : 0.6m | The plug housing assembled harness should be dropped to the concrete surface 3times in every direction. See Fig.14 |
| 3.5.25 | Sealing Performance | Send 98kpa compressed and no air leakage or dripping water is allowed | Put the connector into 10cm deep water. Then send 9.8 kpa compressed air for 30seconds. If no air leakage is observed, increase the air pressure by 9.8kpa. |
| 3.5.26 | Thermal Resistance | After testing, it should be satisfied under test items. 3.5.2 Termination Resistance (Low Level) 3.5.3 Termination Resistance (Specified Current) 3.5.10 Contact Retention Force 3.5.11 Locking Strength 3.5.25 Sealing Performance | Leave the mated connector at a temperature of 120°C for 120hours. |
| 3.5.27 | Termination Current Cycling | After each testing, it should be satisfied under test items. 3.5.2 Termination Resistance (Low Level) 3.5.3 Termination Resistance (Specified Current) | Follow testing in this order. 3.5.21 Decay Resistance (Insertion and Removal :10times) 3.5.22 Wrench Resistance 3.5.26 Temperature Life 3.5.23 Vibration(High Frequency) (Vibration Direction, Only up and down) 3.5.9 Current Cycle Resistance |

Fig.2(End)

3.6 Product Qualification Test Sequence:

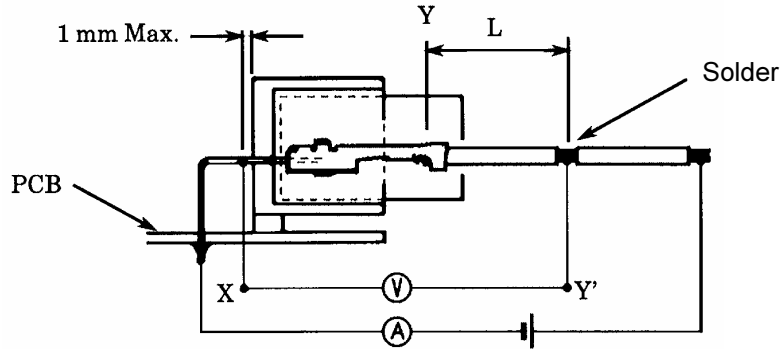

Deduct the resistance of "L" long wire used for termination.

Fig.3

Wrap connector with metallic foil.

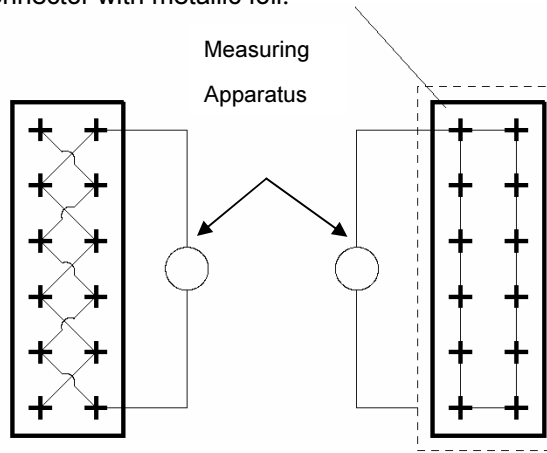

Between the Adjacent Contacts

Between the Contacts and Housing

Fig.4



Fig.5

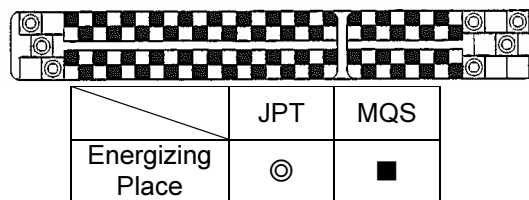

Fig.6

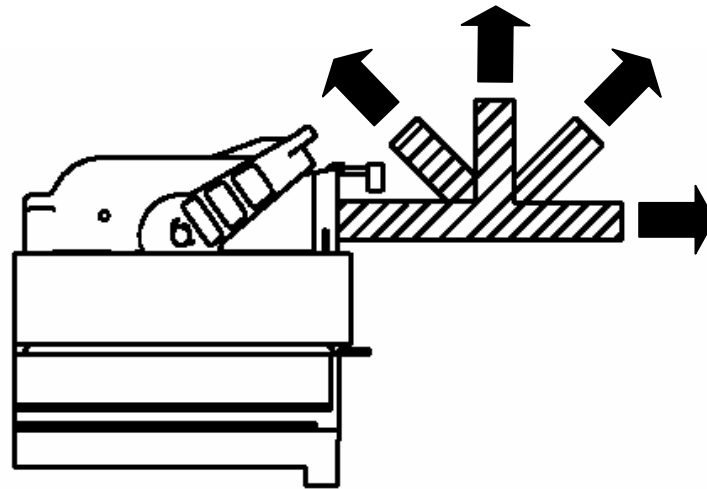

Fig.7

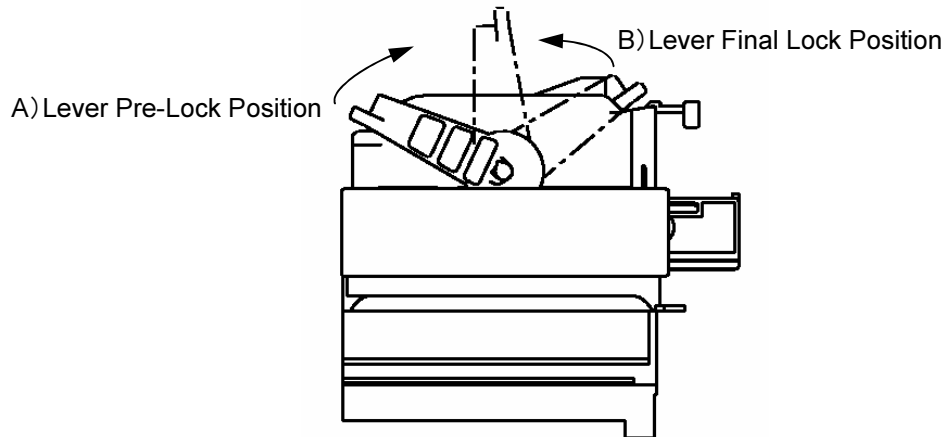

Fig.8

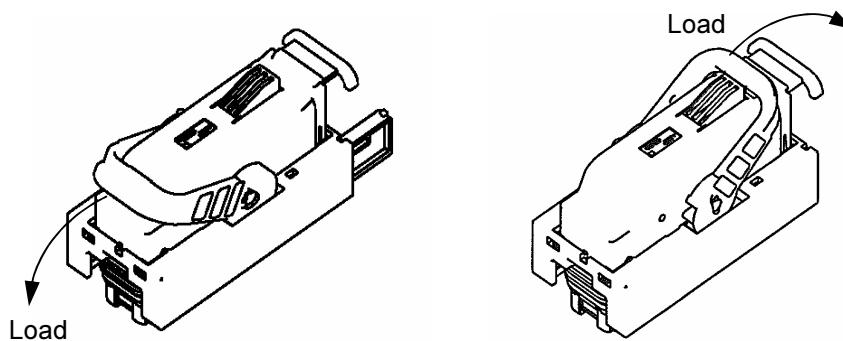

Fig.9

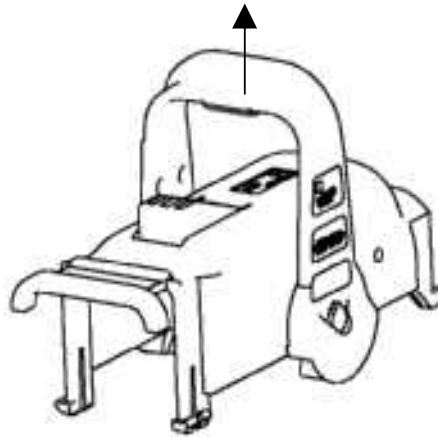

Fig.10

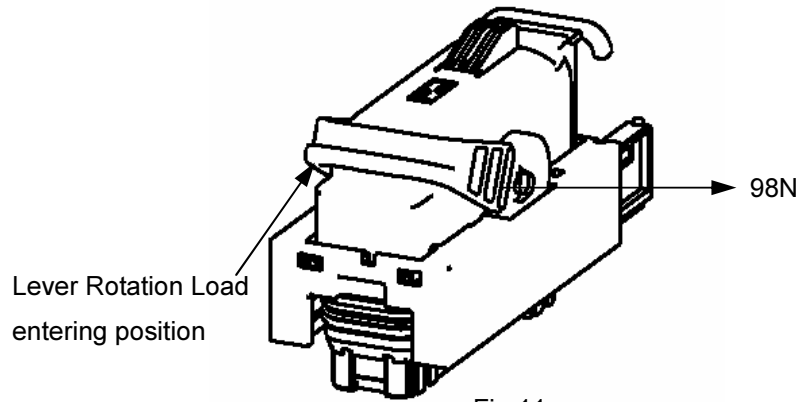

Fig.11

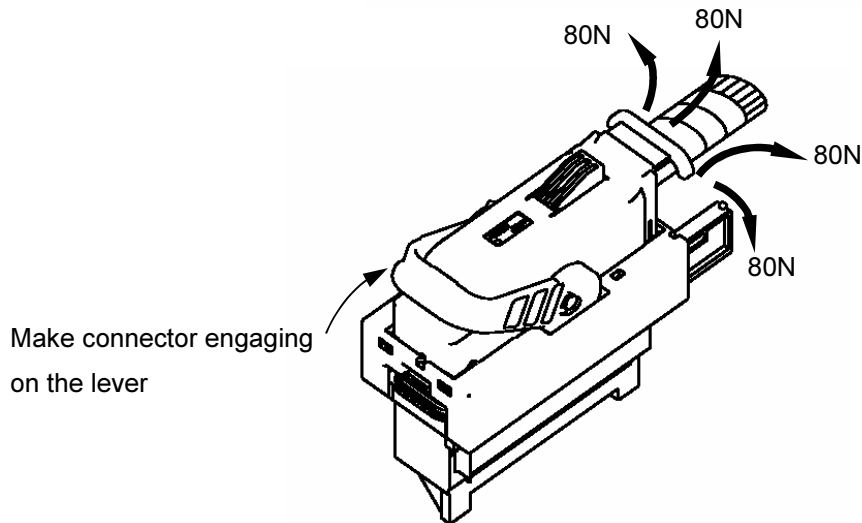

Fig.12

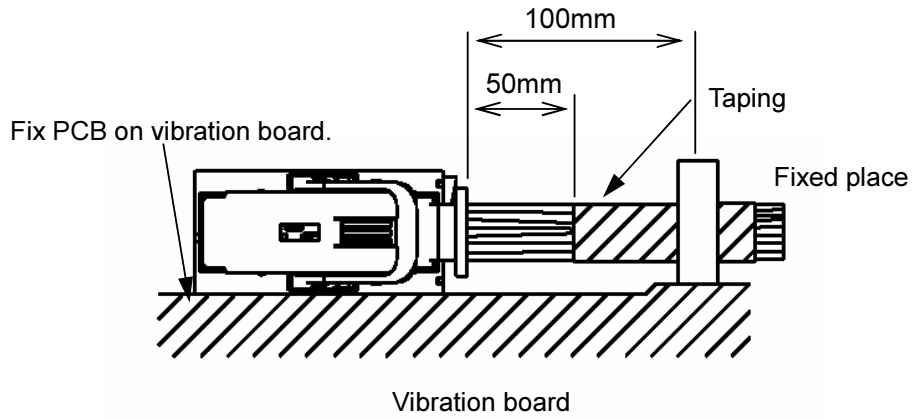

Fig.13

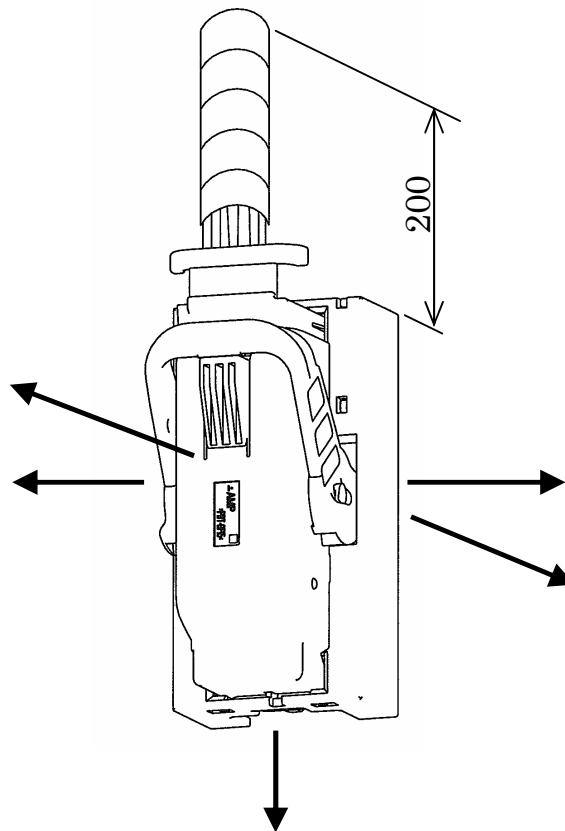

Fig.14

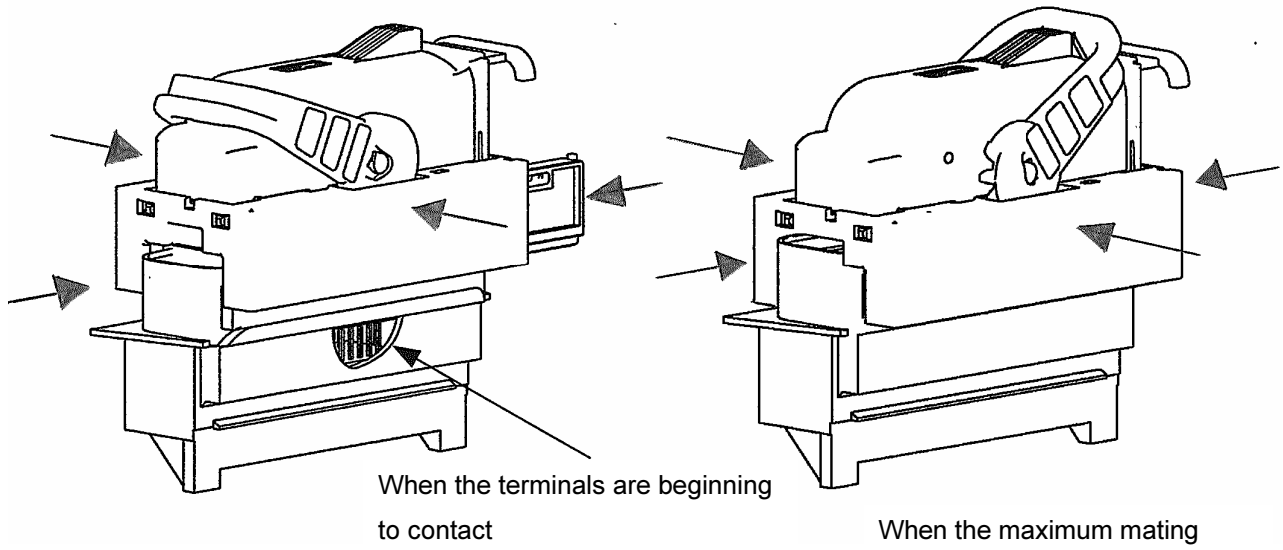

Fig.15

| Part Number | Description |
|-------------|---|
| 1473244 | 81Pos. Plug•Housing•Assembly |
| 1473247 | 81Pos. Lever•Assembly (TYPE-A) |
| 1473250 | 81Pos. Lever•Assembly (TYPE-B) |
| 368382-1 | 81Pos. MQS Retainer for Plug Housing |
| 1473252 | 40Pos. Plug•Housing•Assembly |
| 1473255 | 40Pos. Lever•Assembly (TYPE-A) |
| 368388-1 | 40Pos. MQS Retainer for Plug Housing |
| 1241434-1 | 121Pos. Cap•Housing•Assembly |
| 968220-1 | MQS Receptacle•Contact Tinning (0.5 mm ²) |
| 968221-1 | MQS Receptacle•Contact Tinning (0.75 mm ²) |
| 964282-2 | JPT Receptacle•Contact Tinning (0.5 mm ²) |
| 964286-2 | JPT Receptacle•Contact Tinning (0.5 ~1.0 mm ²) |
| 964273-2 | JPT Receptacle•Contact Tinning (>1.0~2.5 mm ²) |
| 963294-1 | Wire Seal for JPT (Applicable Insulation Diameterφ1.2~2.1mm) |
| 963293-1 | Wire Seal for JPT (Applicable Insulation Diameterφ2~2.7mm) |
| 963292-1 | Wire Seal for JPT (Applicable Insulation Diameterφ2.7~3mm) |
| 936054-1 | Cavity•Plug for MQS |
| 828922-1 | Cavity•Plug for JPT |

Appendix.1