

© 1973 BY AMP INCORPORATED. ALL RIGHTS RESERVED. AMP PRODUCTS COVERED BY PATENTS AND/OR PATENTS PENDING. APPROVED PER GOVT CONTRACT NO.

ZONE	LTR	DESCRIPTION	DATE	APPROVED
G		REDRAWN WITHOUT CHANGE ECN 7128	1-27-66	JH
H		REVISE SHEET TOLERANCE PER ECN Z-632	7-15-68	JH
J		ADDED -5 PER ECN A-491	4-9-70	JH
J1		REV. PER ECN D-644	1-17-75	JH
K		REV. / ECN H-220	8-14-80	JH
L		OBSOLETE -2 & -5 PER ECN R-2604	2-23-87	SPG / JB
M		REV PER DF-2235	7-5-89	JH
N		REV PER OH19-0706-04	10-01	DE
P		REV PER ECD-05-001412	09/05	P.L.C.
R		REV PER ECD-05-005359	11-05	PY/DE

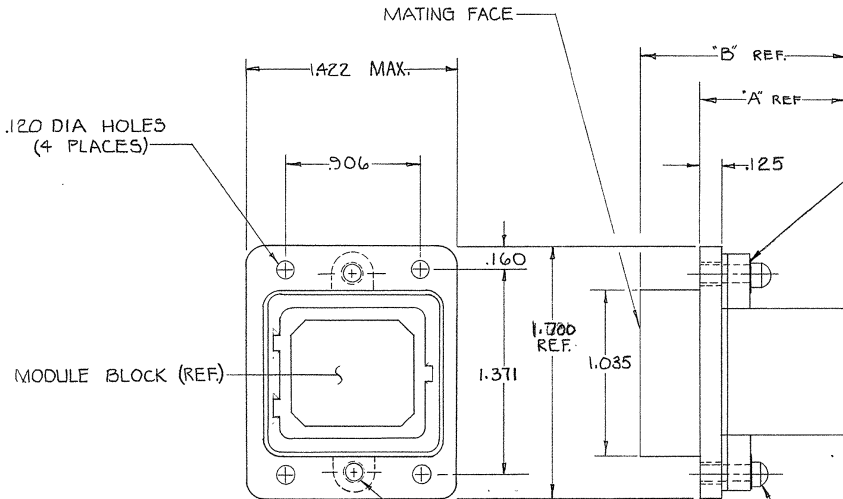

FINISH: PLATED ELECTROLESS NICKEL PER SAE-AAS-C-26074 .000400 - .000600 THK (NO INTENTIONAL ADDITIONS OF LEAD OR CHROMIUM PER DFE STD 230-700).

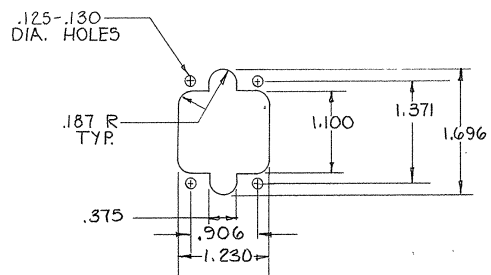

ZINC PLATED STEEL SCREWS (2) FOR -1 THRU -4
 PASSIVATED STAINLESS STEEL SCREWS (2) FOR 5-1, 5-3 & 5-4
 PHILLIPS HEAD SCREWS FOR -1, -2 & 5-1 ONLY
 FILLISTER HEAD SCREWS FOR -3, -4, 5-3 & 5-4

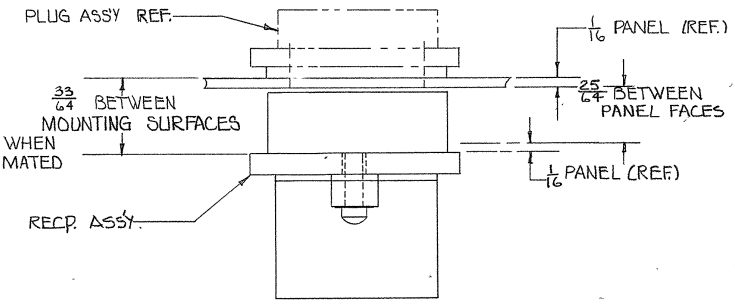

ASSY. NO.	A	FINISH	B
SUPERSEDED BY 5-202279-1	202279-1	1.001 ZINC PLATE PER ASTM-B-633 TYPE II CLASS 3 COLORLESS SUPPLEMENTARY CHROMATE	1.509
	202279-2	1.001 OLIVE DRAB ZINC PLATE PER ASTM-B-633 CLASS 3 TYPE II	1.509
SUPERSEDED BY 5-202279-3	202279-3	1.001 FINISH SAME AS -1	1.509
SUPERSEDED BY 5-202279-4	202279-4	.595 FINISH SAME AS -1	1.103
	202279-5	1.001 FINISH SAME AS -1	1.509
	5-202279-1	1.001 SEE NOTE	1.509
	5-202279-3	1.001 SEE NOTE	1.509
	5-202279-4	.595 SEE NOTE	1.103

UNLESS OTHERWISE SPECIFIED DIMENSIONS ARE IN INCHES TOLERANCES ON FRACTIONS = 1/64 DECIMALS = .005 ANGLES = 4		CONTRACT NO.		AMP INCORPORATED HARRISBURG, PENNSYLVANIA	
MATERIAL	SHELL-DIE CAST ALUMINUM	DR	R. O. Egan	DATE	1-27-66
HEAT TREAT		ENGR	J. J. Miller	DATE	8-5-66
FINISH	SEE TABLE	APP	J. B. Miller	DATE	2-2-66
SIZE	C	CODE IDENT NO	00779	NUMBER	202279
SCALE	2:1	WT		CALC	
		ACTUAL		SHEET	1 OF 1

AMP INFO
 LOC PRINTED IN U.S.A.
 P 1471-1 (8/64)

CUSTOMER DRAWING