

4

3

2

1

THIS DRAWING IS UNPUBLISHED. RELEASED FOR PUBLICATION - N/A.
 © COPYRIGHT N/A. BY - ALL RIGHTS RESERVED.

LOC		DIBT		REVISIONS			
DF	BO	P	LTR	DESCRIPTION	DATE	MIN	APD
		M		REV PER ECO-11-020125	07NOV11	PY	DE

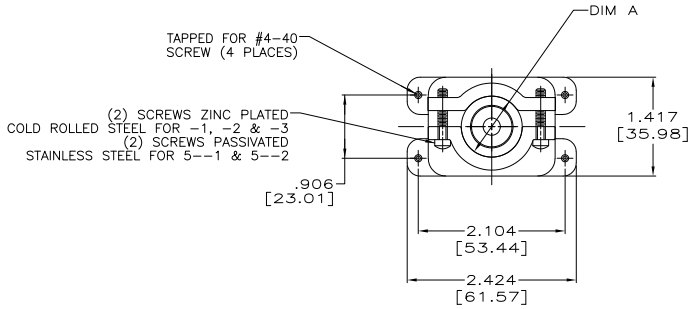

- ⚠ ZINC PLATE PER ASTM-B-633 TYPE II CLASS 3 COLORLESS SUPPLEMENTARY CHROMATE.
- ⚠ TWO RUBBER BUSHINGS SUPPLIED TO PROVIDE .250 [6.35], .625 [15.88], DIAMETER OUTLETS.
- ⚠ AMP, AMP PART NUMBER AND DATE CODE MARKED APPROXIMATELY AS SHOWN.
- 4. SHIELD TO ACCOMMODATE MODULE RECEPTACLE ASSEMBLY OR PLUG ASSEMBLY.
- ⚠ BULK PACKAGED.
- ⚠ PLATED ELECTROLESS NICKEL PER SAE-AMS-C-26074 .000400-.000800 THK (NO INTENTIONAL ADDITIONS OF LEAD OR CADMIUM PER DFE STANDARD 230-700).

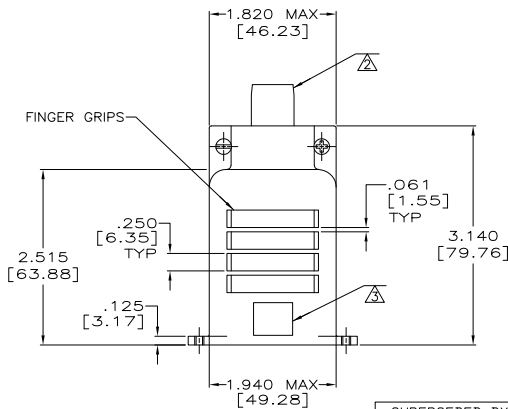

SUPERSEDED BY 5-202617-2
 SUPERSEDED BY 5-202617-1

-	Ø.875	YES	NO	⚠	5-202617-2
-	Ø.875	YES	YES	⚠	5-202617-1
OBSELETE	⚠ Ø.875	YES	YES	⚠	202617-4
OBSELETE	-	Ø1.000	YES	NO	⚠ 202617-3
-	Ø.875	YES	NO	⚠	202617-2
-	Ø.875	YES	YES	⚠	202617-1
REMARKS	DIM A	FINGER GRIPS BOTH SIDES	BUSHINGS	FINISH	PART NUMBER

THIS DRAWING IS A CONTROLLED DOCUMENT.

DESIGNED BY: T. THOMPSON	DATE: 10-NOV-98	TE Connectivity
OK BY: R. BELL	DATE: 10-NOV-98	
APPROVED BY: R. BELL	DATE: 10-NOV-98	NAME: R. BELL
PRODUCT SPEC: -	APPLICATION SPEC: -	SIZE: A2
MATERIAL: ALUMINUM DIE CAST PER QQ-A-591	FINISH: SEE TABLE	WEIGHT: -
CUSTOMER DRAWING		SCALE: 1:1
DRAWING NO: C-202617		SHEET: 1 of 1
REV: M		RESTRICTED TO: -