

NUMBERS C-1734058

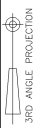

METRIC

PRINT DW
DIMENSIONS IN MILLIMETERS. DO NOT SCALE PRINT.

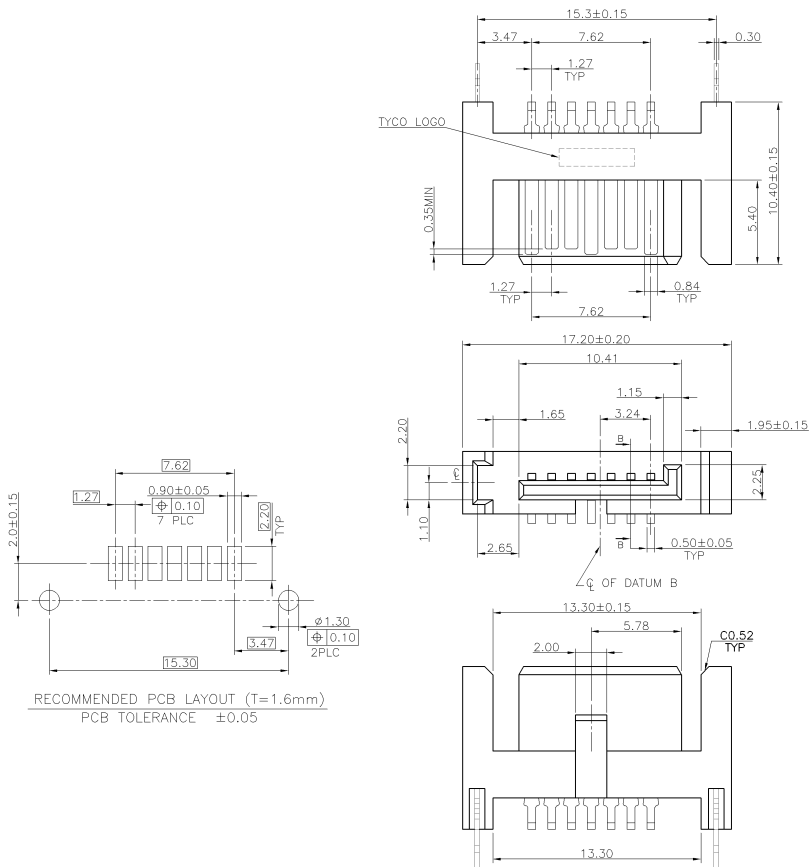

- NOTE:
- MATERIAL:
HOUSING: THERMOPLASTIC (LCP) WITH 30% GF, UL 94V-0, BLACK COLOR.
CONTACTS: BRASS.
BOARDLOCKS: BRASS.
 - FINISH:
CONTACTS: (SEE TABLE) GOLD PLATED ON CONTACT AREA, 100μm MIN. MATTE-TIN ON SOLDER TAIL, WITH ENTIRE CONTACT UNDERPLATED 50μm MIN. NICKEL.
BOARDLOCKS: 100μm MIN. MATTE-TIN OVER 50μm MIN. NICKEL.
 - REFLOW SOLDER CAPABLE TO 260°C AS PER TE Connectivity SPEC. 109-201, CONDITION B.
 - NO DATE CODE ON THE PRODUCT.

3.30	15μ"	1734058-4
2.45	30μ"	1734058-3
	15μ"	1734058-2
	GOLD FLASH	1734058-1
DIM L	GOLD PLATING	PART NUMBER

TOLERANCES UNLESS OTHERWISE SPECIFIED: 0 PLC ± - 1 PLC ± 0.3 2 PLC ± 0.25 3 PLC ± 0.2 ANGLES # 3°	DWN A. WU 06-JUN-2006 CHK S. HOU 06-JUN-2006	NAME STE TE Connectivity
MATERIAL SEE NOTE	APVD W.J. KE 06-JUN-2006	SERIAL ATA, 7 POS., PLUG, VERTICAL, SMT TYPE.
FINISH SEE NOTE	PRODUCT SPEC 108-57261 APPLICATION SPEC - WEIGHT 0.7 g	LOC DW A3 SCALE -

A1	REVISED PER ECO-11-005301	RK HMR	6APR11
LTR	REVISION RECORD	ECO	DATE

CUSTOMER DRAWING 1 OF 2

NUMBERS C-1734058

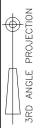

METRIC

DIMENSIONS IN MILLIMETERS. DO NOT SCALE PRINT.

PRINT DW

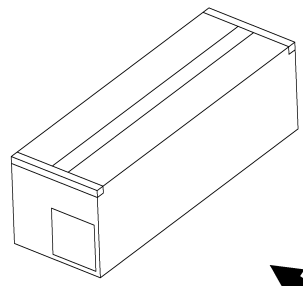

SHIPPING CARTON

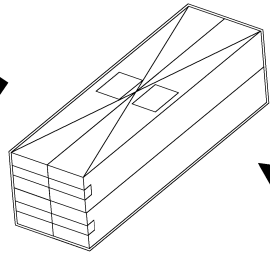

INNER CARTON

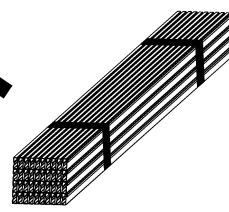

SHEAF

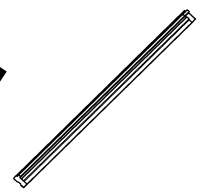

TUBE



PRODUCT

NOTE:

1. DIMENSION
 TRAY: 460 X 7.5 X 15.8
 INNER CARTON: 485 X 86 X 72
 SHIPPING CARTON: 500 X 187 X 169
2. QUANTITY
 25 PCS/TUBE
 40 TUBES/SHEAF
 1 SHEAF/INNER CARTON
 4 INNER CARTON/SHIPPING CARTON
 4000 PCS/SHIPPING CARTON
3. WEIGHT:
 N.W: 5 KG
 G.W: 6 KG

LTR	REVISION RECORD	SEE SHEET 1	ECO	DWN	CHK	DATE
-----	-----------------	-------------	-----	-----	-----	------

TOLERANCES UNLESS OTHERWISE SPECIFIED:		DWN	A. WU	TE Connectivity
0 PLC	±	06-JUN-2006	06-JUN-2006	
1 PLC	±			
2 PLC	±			
3 PLC	±			
ANGLES	±			
MATERIAL	-	APVD	W.J. KE	NAME
			06-JUN-2006	SERIAL ATA, 7 POS., PLUG, VERTICAL, SMT TYPE.
FINISH	-	PRODUCT SPEC	-	LOC
		APPLICATION SPEC	-	SIZE
		WEIGHT	-	DRAWING NO
				C-1734058
				REV
				A1
				SCALE
				2 OF 2
				SHEET

CUSTOMER DRAWING 1

8 7 6 5 4 3 2 1

D
C
B
A