

C.A.D. FILE CODE
S.C344069.A

DO NOT SCALE DIMENSIONS IN MM.

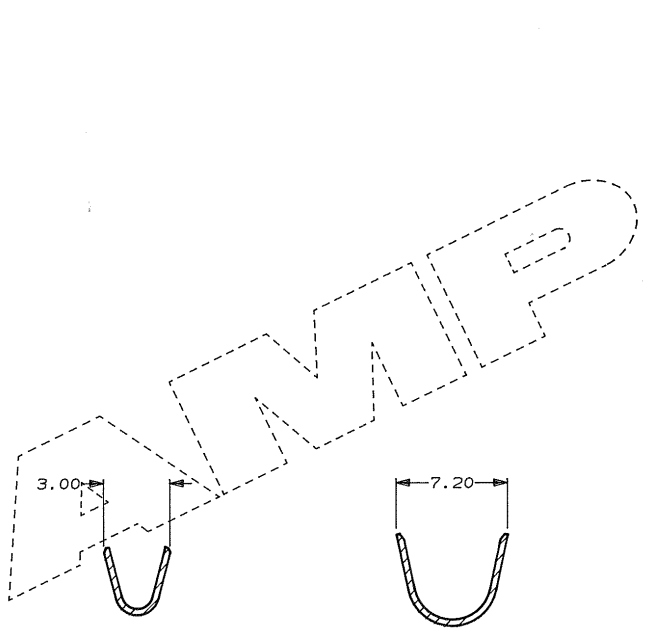
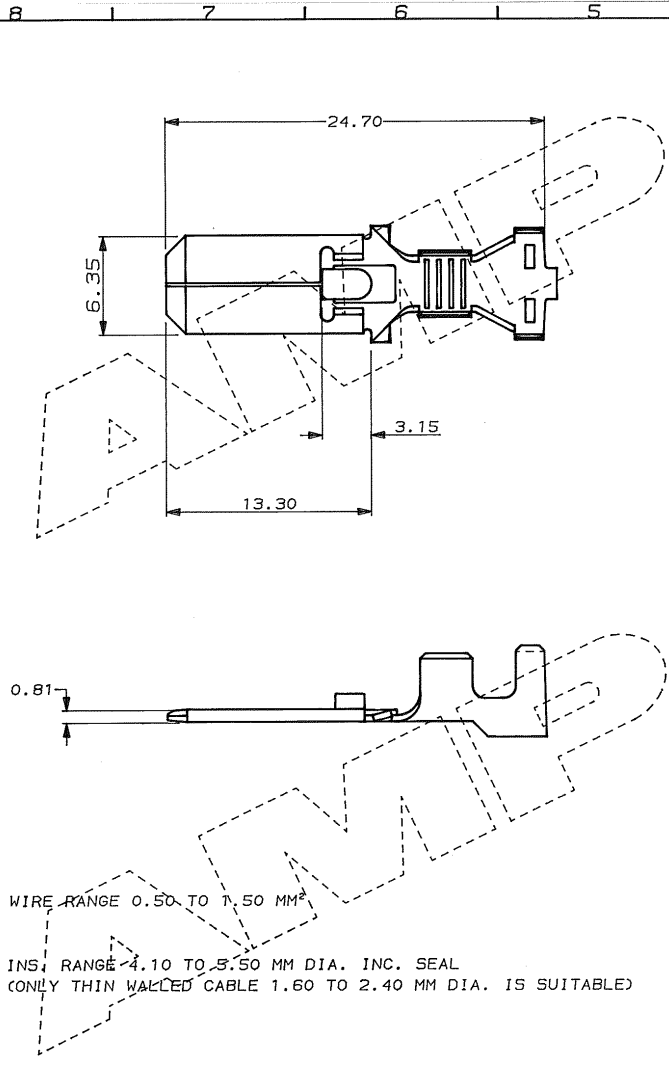

WIRE RANGE 0.50 TO 1.50 MM²
INS. RANGE 4.10 TO 5.50 MM DIA. INC. SEAL
(ONLY THIN WALLED CABLE 1.60 TO 2.40 MM DIA. IS SUITABLE)

TIN PLATED		BRASS		344069-1	
FINISH		MATERIAL		PART NUMBER	
CUSTOMER DWG FOR REFERENCE ONLY		© COPYRIGHT 1987 BY AMP OF GREAT BRITAIN LTD. ALL INTERNATIONAL RIGHTS RESERVED. ALL PRODUCTS MAY BE COVERED BY BRITISH AND FOREIGN PATENTS AND/OR PATENTS PENDING.		RELEASED FOR PUBLICATION 23/06/87	
-	-	TOLERANCES UNLESS OTHERWISE STATED, DEC ± 0.5 ANGLES ± 1°		DR. R. RUNAGALL 23/06/87	
-	-	CH. R. J. S.		APP. B. J.	
-	-	AMP of Great Britain Ltd.		TERMINAL HOUSE STANMORE MIDDXX.	
-	-	NAME .250 SERIES TAB HIGH CURRENT ECONOSEAL 3 (SEALED APPLICATIONS)			
A	UPDATED	CS241	17.5.89	SCALE	LOC
O	REL. FOR PROD.	C4897	8.3.88	SIZE	DWG. No.
REV	APPROVED	ECN	DATE	4/1	E A3
					C344069
					REV
					SHEET
					A 1/1