

THIS DRAWING IS UNPUBLISHED. ALL INFORMATION HEREIN IS UNCLASSIFIED. ALL INFORMATION SUBJECT TO EXPORT CONTROL REGULATIONS. ALL INFORMATION SUBJECT TO EXPORT CONTROL REGULATIONS.

REV	DATE	DESCRIPTION	BY	CHK	APP
00					
01		REVISED PER EDD-10-000073			

△ MOLDED PARTS: GLASS-FILLED NYLON, UL 94V-0 RATED, COLOR BLACK.  
 CONTACTS: PHOSPHOR BRONZE.  
 SHELLS: CARBON STEEL.  
 CLINCH NUTS: CARBON STEEL.

△ SHELLS: 5.08µm[.000200] MIN TIN OVER 2.54µm[.000100] MIN COPPER.  
 CLINCH NUTS: 5.08µm[.000200] MIN ZINC WITH CLEAR CHROMATE COATING.  
 CONTACTS: 0.76µm[.000030] MIN GOLD FOR A LENGTH OF 2.54[.100] MIN FROM MATING END, 2.54µm[.000100] MIN TIN ON OPPOSITE END, BOTH OVER 1.27µm[.000050] MIN NICKEL.  
 -OR-  
 GOLD FLASH OVER PALLADIUM-NICKEL 0.76µm[.000030] MIN TOTAL, PLATED FOR A LENGTH OF 2.54[.100] MIN FROM MATING END, 2.54µm[.000100] MIN TIN ON OPPOSITE END, BOTH OVER 1.27µm[.000050] MIN NICKEL.

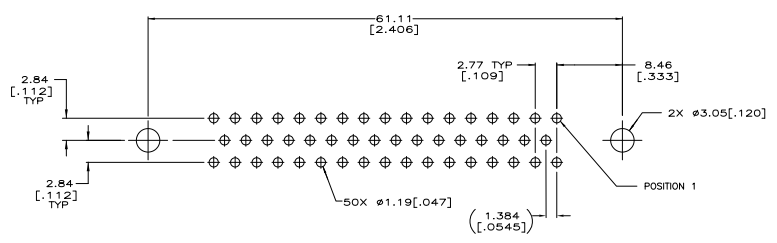
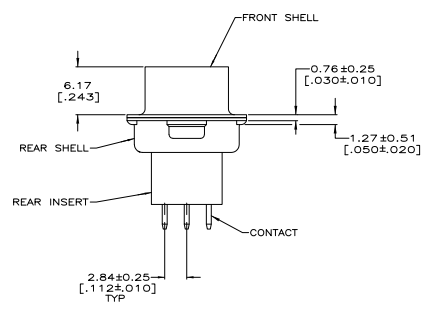
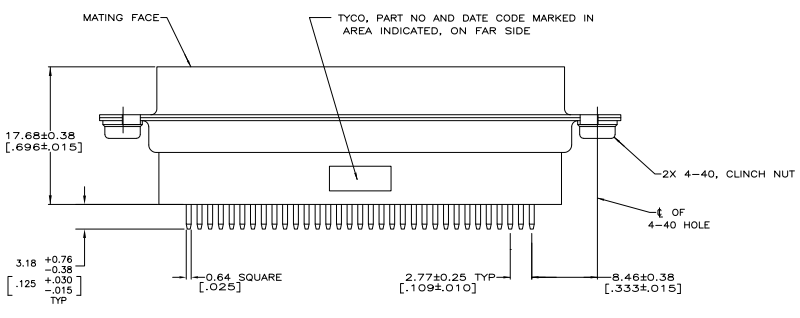
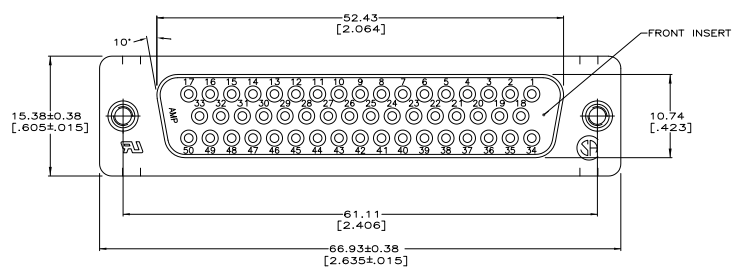

RECOMMENDED PC BOARD MOUNTING DIMENSIONS

5747302-1  
PART NO

THIS DRAWING IS A CONTROLLED DOCUMENT.		DATE	REVISED	BY	CHK	APP
DATE	REVISED	BY	CHK	APP	TYS Electronics Corporation Harrisburg, PA 17105-3608	
DATE	REVISED	BY	CHK	APP	RECEPTACLE ASSEMBLY, SIZE 50, 50 POSN, VERTICAL, FRONT METAL SHELL, AMPLIFIER HS-20	
DATE	REVISED	BY	CHK	APP	108-40025	REVISION NO
DATE	REVISED	BY	CHK	APP	114-40013	SIZE
DATE	REVISED	BY	CHK	APP	A1	00779
DATE	REVISED	BY	CHK	APP	CUSTOMER DRAWING	