

4

3

2

1

THIS DRAWING IS UNPUBLISHED. RELEASED FOR PUBLICATION
 © COPYRIGHT - BY TYCO ELECTRONICS CORPORATION. ALL RIGHTS RESERVED.

LOC	DIST	REVISIONS				
P	LTR	DESCRIPTION	DATE	DWN	APVD	
FT	0					
	A1	REVISED PER ECO-09-024209	27JAN10	HMR	CR	

MATERIAL:
 HOUSING: POLYAMIDE 6/6, UL94V-0.
 COLOR: BROWN.
 TUBULAR CONTACT: TIN PLATED, BRASS.
 SCREW: M3.5 STEEL, ZINC PLATED W/ NON-
 HEXAVALENT CHROMATE (CHROME III).
 WIRE PROTECTOR: STAINLESS STEEL.

CURRENT RATING: 40A.
 OPERATING VOLTAGE: 250V.
 WIRE RANGE: 10-24 AWG.

CONTINUOUS WORKING TEMP.: -50°C TO +160°C.

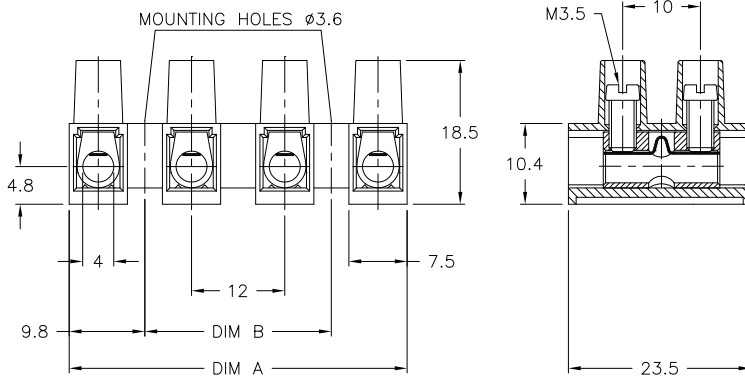

120	139.5	12	TSB100012DSHT	1-1776304-2
108	127.5	11	TSB100011DSHT	1-1776304-1
96	115.5	10	TSB100010DSHT	1-1776304-0
84	103.5	9	TSB100009DSHT	1776304-9
72	91.5	8	TSB100008DSHT	1776304-8
60	79.5	7	TSB100007DSHT	1776304-7
48	67.5	6	TSB100006DSHT	1776304-6
36	55.5	5	TSB100005DSHT	1776304-5
24	43.5	4	TSB100004DSHT	1776304-4
12	31.5	3	TSB100003DSHT	1776304-3
-	19.5	2	TSB100002DSHT	1776304-2
-	7.5	1	TSB100001DSHT	1776304-1
DIM B	DIM A	NO. OF POS.	CATALOG NUMBER	PART NO.

THIS DRAWING IS A CONTROLLED DOCUMENT.		DWN	3/21/05	Tyco Electronics Corporation	
DIMENSIONS: mm		CHK	S SCHLEGEL	Harrisburg, Pa 17105-3608	
TOLERANCES UNLESS OTHERWISE SPECIFIED:		APVD	C RICHARD	NAME	
0 PLC ± -		PRODUCT SPEC	C RICHARD	12mm PITCH, EUROPA TERMINAL BLOCK	
1 PLC ± 0.7		APPLICATION SPEC		HIGH TEMP.	
2 PLC ± 0.25		WEIGHT		SIZE	CAGE CODE
3 PLC ± -				A3	00779
4 PLC ± -				DRAWING NO	1776304
ANGLES ± 2°				RESTRICTED TO	-
MATERIAL	FINISH	CUSTOMER DRAWING	SCALE	NTS	SHEET 1 OF 1
					REV A1

AMP 1470-19 REV 31MAR2000