

REV	DATE	DESCRIPTION	BY	CHK	APP
P2		REVISED PER ECO-11-024001			

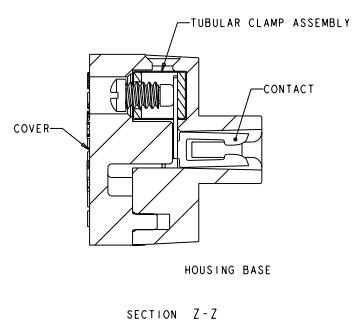

- △ PHYSICAL PROPERTIES:
 HOUSING BASE - POLYESTER, COLOR: BLACK.
 COVER - POLYESTER, COLOR: BLACK.
 CONTACT - PHOSPHOR BRONZE, GOLD PLATED.
 TUBULAR CLAMP ASSY:
 TUBULAR CONTACT - BRASS, UNPLATED.
 #6-32 SCREW - STEEL, ZINC PLATED CLEAR CHROMATE.
 CUP CLAMP - BRASS, UNPLATED.
2. MECHANICAL PROPERTIES:
 OPERATING TEMPERATURE RANGE: -65°C TO +140°C.
 RECOMMENDED TIGHTENING TORQUE: 5-8 IN.-LBS.
3. ELECTRICAL PROPERTIES:
 MAXIMUM CURRENT: 10A
 OPERATING VOLTAGE: 250V
 WIRE RANGE: #12 STRANDED ONLY

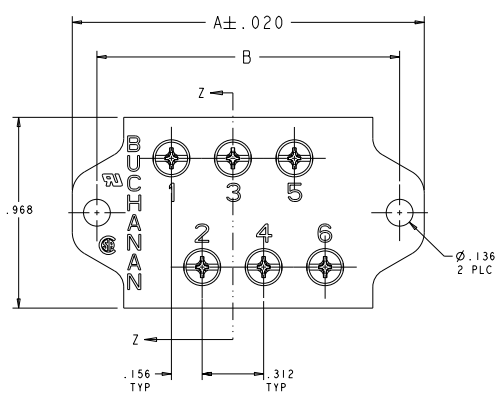
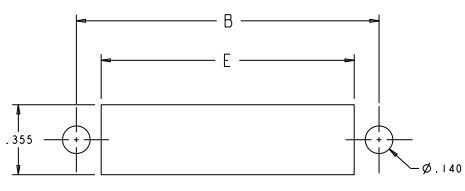
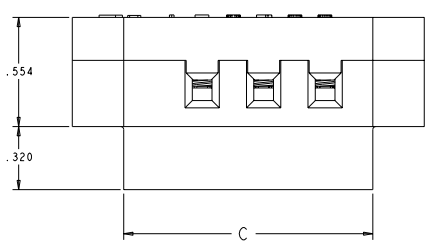

RECOMMENDED PANEL CUTOUT

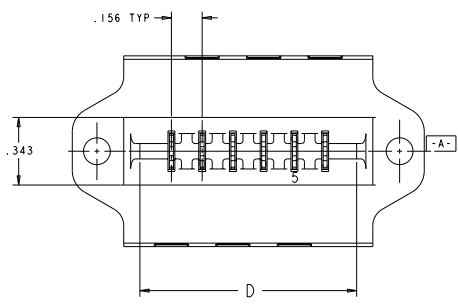

OBSELETE

PCB2B43A	7.056	6.872	7.036	7.308	7.558	43	8-1437410-4
PCB2B36A	5.964	5.780	5.944	6.216	6.466	36	8-1437410-2
PCB2B30A	5.028	4.844	5.008	5.280	5.530	30	8-1437410-0
PCB2B28A	4.716	4.532	4.696	4.968	5.218	28	7-1437410-8
PCB2B24A	4.092	3.908	4.072	4.344	4.594	24	7-1437410-7
PCB2B22A	3.780	3.596	3.760	4.032	4.282	22	7-1437410-5
PCB2B18A	3.156	2.972	3.136	3.408	3.658	18	7-1437410-3
PCB2B16A	2.844	2.660	2.824	3.096	3.346	16	7-1437410-1
PCB2B15A	2.688	2.504	2.668	2.940	3.190	15	6-1437410-9
PCB2B12A	2.220	2.036	2.200	2.472	2.722	12	6-1437410-7
PCB2B10A	1.908	1.724	1.888	2.160	2.410	10	6-1437410-5
PCB2B09A	1.752	1.568	1.732	2.004	2.254	9	-
PCB2B08A	1.596	1.412	1.576	1.848	2.098	8	6-1437410-2
PCB2B06A	1.284	1.100	1.264	1.536	1.786	6	5-1437410-9
CATALOG NUMBER	E	D	C	B	A	NO OF POSN	PART NUMBER

THIS DRAWING IS A CONTROLLED DOCUMENT. ILLUMINON 880072003
 INCHES. 880072003
 CONNECTOR ASSEMBLY, CARD EDGE, PCB2BXXA
 STATE CASE CODE DRAWING NO. 00779
 CUSTOMER DRAWING