

REVISIONS			
REV	DESCRIPTION	DATE	BY
A1	REVISED PER ECO-08-031201	18DEC2008	HMR CR

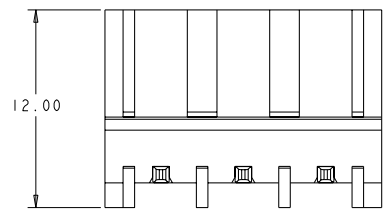

- △ MATERIALS AND FINISH:  
HOUSING: HIGH TEMPERATURE POLYAMIDE, UL 94V-0 RATED,  
COLOR: BLACK.  
TERMINAL: PHOSPHOR BRONZE, SEE TABLE.
- 2. SUITABLE FOR 1,6-2, 4mm PC BOARD THICKNESS.
- 3. RECOGNIZED UNDER THE COMPONENT PROGRAM OF UNDERWRITERS LABORATORIES INC. FILE N° E60677.
- 4. IMO CERTIFICATE WITH SURVEILLANCE IN CONFORMITY WITH IEC 998-1/998-2-1.
- 5. UL RATING 300V, 15A.
- △ TAPE AND REEL PACKAGED.
- △ PRELIMINARY PART NUMBER.

PLATING	DIM L	NO OF POSN	PART NUMBER
TIN	16.8	3	2-1776148-3
	26.8	5	1-1776148-3
	61.8	12	1-1776148-2
	56.8	11	1-1776148-1
	51.8	10	1-1776148-0
	46.8	9	1776148-9
	41.8	8	1776148-8
	36.8	7	1776148-7
	31.8	6	1776148-6
	26.8	5	1776148-5
	21.8	4	1776148-4
16.8	3	1776148-3	
11.8	2	1776148-2	

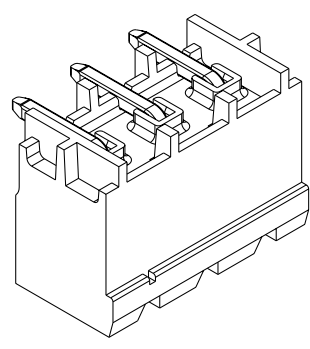
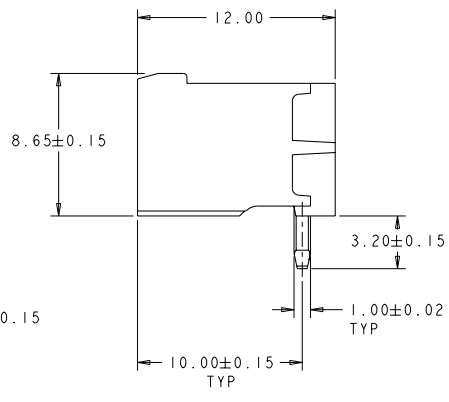
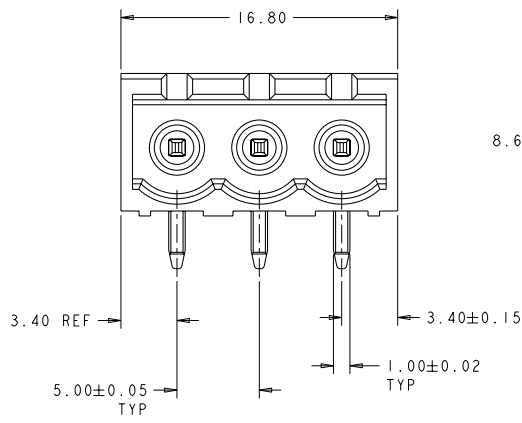
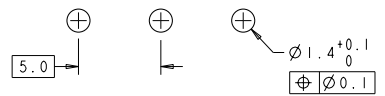

RECOMMENDED PC BOARD LAYOUT

DIMENSIONS: mm 0 PLC ±0.1 1 PLC ±0.1 2 PLC ±0.25 3 PLC ±0.1 4 PLC ±0.1 ANGLES ±0.1 FINISH △		DWN 07JUN2005 S. WELDON C. RICHARD C. RICHARD PRODUCT SPEC APPLICATION SPEC WEIGHT MATERIAL △ FINISH △	07JUN2005 07JUN2005 07JUN2005 NAME TERMINAL BLOCK HEADER ASSEMBLY, 90 DEGREE, CLOSED ENDS, 5.00mm PITCH SHEET CASE CODE DRAWING NO A2 00779 C-1776148 CUSTOMER DRAWING	Tyco Electronics Harrisburg, PA 17105-3608 SCALE 6:1 SHEET 1 OF 1 REV A1
--	--	--	---	--