Multi-Beam XL* Cable Panel Mount and Squeeze-To-Release Receptacles

1. SCOPE

1.1. Content

This specification covers performance, tests and quality requirements for the Tyco Electronics Multi-Beam XL* Cable Panel Mount and Squeeze-To-Release Receptacles.

1.2. Qualification

When tests are performed on the subject product line, procedures specified in Figure 3 shall be used. All inspections shall be performed using the applicable inspection plan and product drawing.

1.3. Qualification Test Results

Successful qualification testing on the subject product line was completed on 02Dec04. The Qualification Test Report number for this testing is 501-597. This documentation is on file at and available from Engineering Practices and Standards (EPS).

Additional testing on part number 1874902-1 using 12 AWG wire on 3 adjacent contacts and .300 pitch at 28 amperes was performed by TUV. The project number for this testing is S1600403-101.

2. APPLICABLE DOCUMENTS

The following documents form a part of this specification to the extent specified herein. Unless otherwise specified, the latest edition of the document applies. In the event of conflict between the requirements of this specification and the product drawing, the product drawing shall take precedence. In the event of conflict between the requirements of this specification and the referenced documents, this specification shall take precedence.

2.1. Tyco Electronics Documents

- 109-197: Test Specification (AMP Test Specifications vs EIA and IEC Test Methods)
- 114-13112: Application Specification (Multi-Beam XL Cable Receptacle Assemblies)
- 501-597: Qualification Test Report (Multi-Beam XL* Cable Panel Mount and Squeeze-To-Release Receptacles)

2.2. Industry Standard

EIA-364: Electrical Connector/Socket Test Procedures Including Environmental Classifications

3. REQUIREMENTS

3.1. Design and Construction

Product shall be of the design, construction and physical dimensions specified on the applicable product drawing.

3.2. Materials

Materials used in the construction of this product shall be as specified on the applicable product drawing.

3.3. Ratings

- Voltage: See Figure 1
- Current: See Figure 2
- Temperature: -20 to 105°C

Contact Type	Contact Pitch	Within Primary Circuits	Primary to Secondary Circuits	Primary to Ground Circuits	Within Secondary Circuits
Signal	.100 [2.54 mm]	60*	60*	60*	60*
Power	.200 [5.08 mm]	60*	60*	60*	60*
Power	.250 [6.35 mm]	200	NR	200	200
Power	.300 [7.62 mm]	300	150	300	300

Figure 1
Volts RMS (Safety Extra Low Voltage* (SELV)) Circuits

Signal Contacts		Power Contacts							
Single Contact	System (24 contacts, 22 AWG)	Module (Contact Pitch)	Wire Size	Single Contact	2 Adjacent Contacts	3 Adjacent contacts	4 Adjacent Contacts	8 Adjacent Contacts	12 Adjacent Contacts
5	1.5	.300	8	50	42	---	35	-----	-----
		.300	12	---	---	28	---	---	---
		.250	10	43	-----	---	29	25	23
		.250	14	31	-----	---	20	17	17

Figure 2
Current (amperes)

3.4. Performance and Test Description

Product is designed to meet the electrical, mechanical and environmental performance requirements specified in Figure 3. Unless otherwise specified, all tests shall be performed at ambient environmental conditions per EIA-364.

3.5. Test Requirements and Procedures Summary

Test Description	Requirement	Procedure
Initial examination of product.	Meets requirements of product drawing.	EIA-364-18. Visual and dimensional (C of C) inspection per product drawing.
Final examination of product.	Meets visual requirements.	EIA-364-18. Visual inspection.
ELECTRICAL		
Low level contact resistance, signal and power contacts.	Power contacts: 10 milliohms maximum initial. 20 milliohms maximum final.	EIA-364-23. Subject specimens to 100 milliamperes maximum and 20 millivolts maximum open circuit voltage.
Low level contact resistance, power contacts only.	Signal contacts: 15 milliohms maximum initial. 20 milliohms maximum final.	

Figure 3 (cont)

Test Description	Requirement	Procedure
Contact resistance at rated current, power contacts.	0.7 milliohm maximum, end of life. Wire Size (AWG) Test Current (amperes DC) 8 35 10 20 14 15	EIA-364-6. At rated DC test current.
Insulation resistance.	500 megohms minimum for signal contacts. 1000 megohms minimum for power contacts.	EIA-364-21. Test between adjacent contacts.
Withstanding voltage.	1 minute hold with no breakdown or flashover.	EIA-364-20, Condition I. 1000 volts DC at sea level for signal contacts. 2500 volts DC at sea level for power contacts. Test between adjacent contacts.
Temperature rise vs current.	30°C maximum temperature rise at specified current.	EIA-364-70, Method 1. Stabilize at a single current level until 3 readings at 5 minute intervals are within 1°C.
MECHANICAL		
Vibration, random.	No discontinuities of 1 microsecond or longer duration. See Note.	EIA-364-28, Test Condition VII, Condition E. Subject mated specimens to 4.90 G's rms between 20-500 Hz. Fifteen minutes in each of 3 mutually perpendicular planes.
Mechanical shock.	No discontinuities of 1 microsecond or longer duration. See Note.	EIA-364-27, Method A. Subject mated specimens to 50 G's half-sine shock pulses of 11 milliseconds duration. Three shocks in each direction applied along 3 mutually perpendicular planes, 18 total shocks.
Durability.	See Note.	EIA-364-9. Mate and unmate specimens for 250 cycles at a maximum rate of 500 cycles per hour.
Mating force.	Average mating force for power contacts shall be less than 28 ounces per contact. Average mating force for signal contacts shall be less than 6 ounces per contact.	EIA-364-13. Measure force necessary to mate specimens at a maximum rate of .5 inch per minute. Measure signal contacts using gage 1. See Figure 5.

Figure 3 (cont)

Test Description	Requirement	Procedure
Unmating force.	8 ounce minimum per power contact. .7 ounce minimum per signal contact.	EIA-364-13. Measure force necessary to unmate specimens at a maximum rate of 1 inch per minute. Size signal contacts 3 times using gage 1, then insert gage 2 and measure force necessary to separate. See Figure 5.
Contact insertion force, power contacts.	6 pounds maximum.	EIA-364-5. Measure force necessary to insert contact into housing.
Contact retention, straight pull.	30 pounds minimum for power contact. 3 pounds minimum for signal contact.	EIA-364-29. Apply axial load to wire, as crimped to contacts. Power contact retention shall be qualified with TPA lock and primary lance(s) engaged. Signal contact retention shall be qualified in 2 independent modes: 1) primary lance only; and 2) secondary TPA lock only. Signal TPA lock shall withstand 3 pounds minimum on a singly loaded wire.
Contact retention, angled pull.		Apply load to single wires at a 45 degree angle in 4 directions from normal exit plane of cable. Both power and signal contact shall be qualified with TPA locks and primary lance(s) engaged.
Housing lock strength, straight pull.	25 pounds minimum.	EIA-364-98. Apply axial force to mated pair using securely mounted vertical header (4-40 cap screw and nut through mounting hole and printed circuit board). Apply force in straight pull in direction normal to plane of cable entrance.
Housing lock strength, angles pull.		Apply load to wire bundle of mated pair at a 45 degree angle in 4 directions from the normal exit plane of the cable connector with the mated vertical header securely mounted.

Figure 3 (cont)

Test Description	Requirement	Procedure																								
Crimp tensile.	<p>Power Contact</p> <table border="1"> <thead> <tr> <th>Wire Size (AWG)</th> <th>Tensile (Lbs min)</th> </tr> </thead> <tbody> <tr> <td>8</td> <td>80</td> </tr> <tr> <td>10</td> <td>80</td> </tr> <tr> <td>14 (dual crimp)</td> <td>80</td> </tr> <tr> <td>12 (dual crimp)</td> <td>80</td> </tr> <tr> <td>12</td> <td>70</td> </tr> <tr> <td>16 (dual crimp)</td> <td>50</td> </tr> <tr> <td>14</td> <td>50</td> </tr> </tbody> </table> <p>Signal Contact</p> <table border="1"> <thead> <tr> <th>Wire Size (AWG)</th> <th>Tensile (Lbs min)</th> </tr> </thead> <tbody> <tr> <td>22</td> <td>11.0</td> </tr> <tr> <td>24</td> <td>7.0</td> </tr> <tr> <td>26</td> <td>4.0</td> </tr> </tbody> </table>	Wire Size (AWG)	Tensile (Lbs min)	8	80	10	80	14 (dual crimp)	80	12 (dual crimp)	80	12	70	16 (dual crimp)	50	14	50	Wire Size (AWG)	Tensile (Lbs min)	22	11.0	24	7.0	26	4.0	EIA-364-8. Determine crimp tensile at a rate of .5 inch per minute. Clamp contacts as shown in Figure 6.
Wire Size (AWG)	Tensile (Lbs min)																									
8	80																									
10	80																									
14 (dual crimp)	80																									
12 (dual crimp)	80																									
12	70																									
16 (dual crimp)	50																									
14	50																									
Wire Size (AWG)	Tensile (Lbs min)																									
22	11.0																									
24	7.0																									
26	4.0																									
ENVIRONMENTAL																										
Thermal shock.	See Note.	EIA-364-32. Subject specimens to 36 cycles between -20 and 105°C.																								
Humidity-temperature cycling.	See Note.	EIA-364-31, Method III, Condition B without cold shocks. Subject specimens to 10 cycles (10 days) between 25 and 40°C at 80 to 95% RH.																								
Temperature life.	See Note.	EIA-364-17, Method A, Test Condition 4. Subject mated specimens to 105°C for 504 hours (21 days).																								
Mixed flowing gas.	See Note.	EIA-364-65, Class IIA (4 gas). Subject mated specimens to environmental Class IIA for 20 days.																								

NOTE *Shall meet visual requirements, show no physical damage, and meet requirements of additional tests as specified in the Product Qualification and Requalification Test Sequence shown in Figure 4.*

Figure 3 (end)

3.6. Product Qualification and Requalification Test Sequence

Test or Examination	Test Group (a)						
	1	2	3	4	5	6	7
	Test Sequence (b) ¹						
Initial examination of product	1	1	1	1	1	1	1
Low level contact resistance, signal and power contacts	2,5	3,7		2,4			
Low level contact resistance, power contacts only					2,6,8,10		
Contact resistance at rated current, power contacts					12		
Insulation resistance			3,7				
Withstanding voltage			4,8				
Temperature rise vs current					4,11		
Vibration, random		5			9(c)		
Mechanical shock		6					
Durability	3(d)	4			3(f)		
Mating force		2(e)					
Unmating force		8(e)					
Contact insertion force, power contacts			2				
Contact retention, straight pull			10				
Contact retention, angled pull							2
Housing lock strength, straight pull			9				
Housing lock strength, angled pull							3
Crimp tensile						2	
Thermal shock			5				
Humidity-temperature cycling			6				
Temperature life				3	7		
Mixed flowing gas	4				5		
Final examination of product	6	9	11	5	13	3	4

NOTE

- (a) See paragraph 4.1.A.
- (b) Numbers indicate sequence in which tests are performed.
- (c) Energize at current for 18 °C temperature rise.
- (d) Precondition specimens with 5 durability cycles.
- (e) Power only in housing, signal with gage.
- (f) Precondition specimens with 50 durability cycles

Figure 4

4. QUALITY ASSURANCE PROVISIONS

4.1. Qualification Testing

A. Specimen Selection

Specimens shall be prepared in accordance with applicable Instruction Sheets and shall be selected at random from current production. Test group 1 shall consist of 6 mated pairs (panel mount receptacle to right angle header, with 8 and 14 AWG wires). Test group 2 shall consist of 12 mated pairs (panel mount to right angle header and squeeze-to-release to Vertical header, with sampling of all single crimp wire configurations). Test group 3 shall consist of 10 mated pairs (panel mount to right angle header and straight to vertical header, with 8 and 10 AWG wires). Test group 4 shall consist of 10 mated pairs (panel mount to right angle header and straight to vertical header, with 8 and 10 AWG wires). Test group 5 shall consist of a minimum of 11 mated pairs (panel mount to right angle header), 3 specimens with 10 AWG wires, 3 specimens with 14 AWG wires, and 5 specimens with 8 AWG wires. Test group 6 shall consist of 12 contacts per specified wire crimp combination. All contact insertion/retention tests shall consist of 15 contacts, secondary locks, and housing circuits. Test group 7 shall consist of 32 power contacts with 10 AWG wires and 24 signal contacts with 22 AWG wires installed in various locations in the cable connector housings for the contact retention angled pull test. Specimens for the housing lock strength angled pull test shall consist of 12 mated pairs using power contacts with 8 AWG wire for the ACP positions and 10 AWG wire for the standard power positions.

Test collaterals are as follows:

1. Temperature rise printed circuit boards 60-474407 and 60-474408.
2. Low level contact resistance and mechanical board 60-474409.
3. Vibration fixture top plate 39-474410, bottom plate 39-474411, and vibration panel 39-474412.

B. Test Sequence

Qualification inspection shall be verified by testing specimens as specified in Figure 4.

4.2. Requalification Testing

If changes significantly affecting form, fit or function are made to the product or manufacturing process, product assurance shall coordinate requalification testing, consisting of all or part of the original testing sequence as determined by development/product, quality and reliability engineering.

4.3. Acceptance

Acceptance is based on verification that the product meets the requirements of Figure 3. Failures attributed to equipment, test setup or operator deficiencies shall not disqualify the product. If product failure occurs, corrective action shall be taken and specimens resubmitted for qualification. Testing to confirm corrective action is required before resubmittal.

4.4. Quality Conformance Inspection

The applicable quality inspection plan shall specify the sampling acceptable quality level to be used. Dimensional and functional requirements shall be in accordance with the applicable product drawing and this specification.

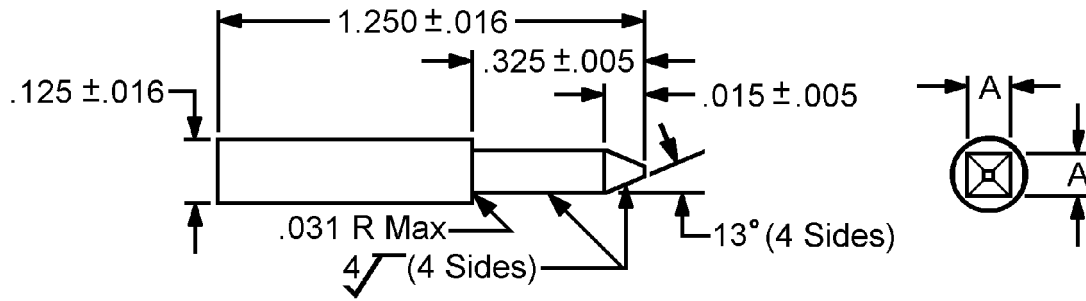

Gage Number	"A" Dimension
1	.0260 +.0000/-.0001
2	.0240 +.0001/-.0000

NOTE

1. Tolerance: Unless otherwise specified, $\pm .005$ or ± 2 degrees as applicable.
2. Material: AISI Type O2 tool steel per Material Specification 100-15.
3. Heat Treat: Rockwell C50-55
4. Gage surface shall be clean of contaminates or lubricants.

Figure 5
Mating and Unmating Force Gages

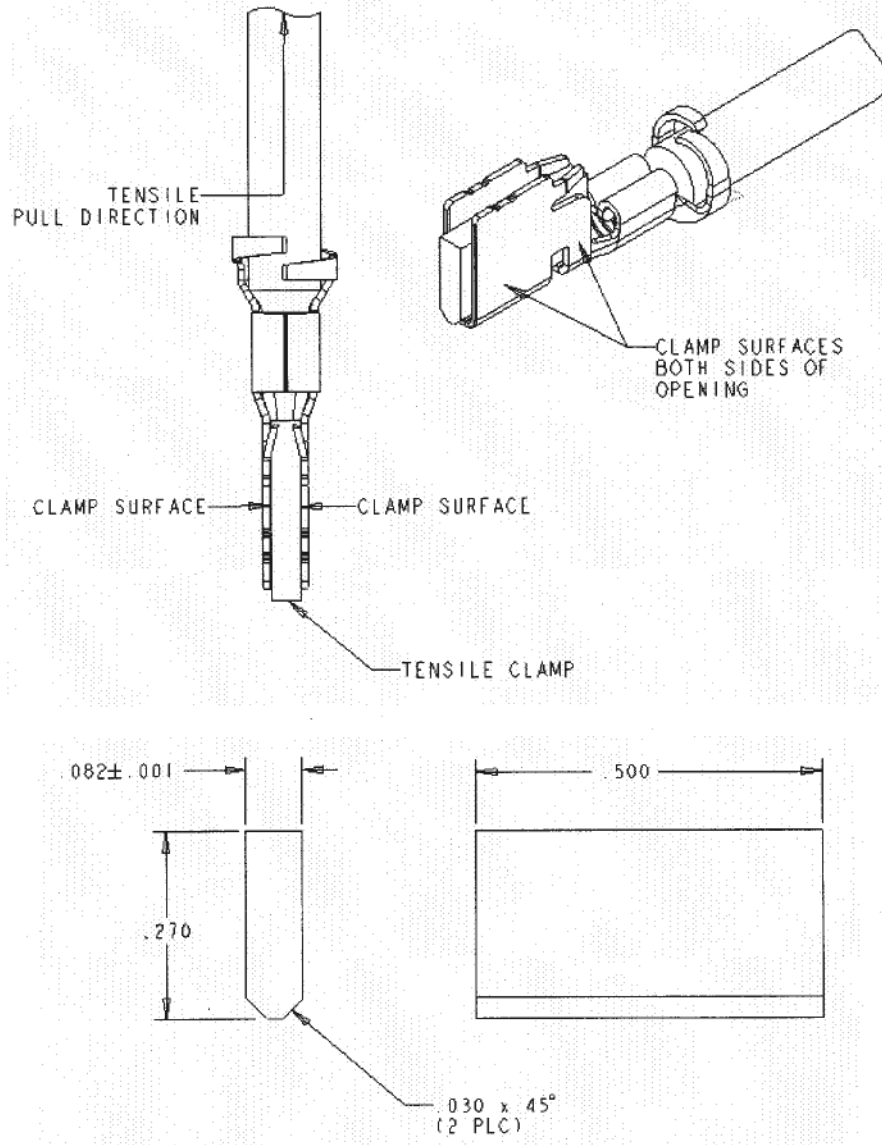

NOTE

1. Tolerance: Unless otherwise specified, ± 0.005 or ± 2 degrees as applicable.
2. Material: AISI Type 02 tool steel per Material Specification 100-15.
3. Heat Treat: Rockwell C50-55.

Figure 6
Power Contact Tensile Test Clamp