

---

**2 mm AMP-LATCH\* Ribbon Cable Receptacle Connector**

---

**1. SCOPE**

## 1.1. Content

This specification covers performance, tests and quality requirements for AMP-LATCH\* 2 mm ribbon cable receptacle connector. Insulation displacement contacts terminated to 1 mm centerline ribbon cable.

## 1.2. Qualification

When tests are performed on the subject product line, procedures specified in Figure 1 shall be used. All inspections shall be performed using the applicable inspection plan and product drawing.

## 1.3. Qualification Test Results

Successful qualification testing on the subject product line was completed on 24Jun94. The Qualification Test Report number for this testing is 501-254. This documentation is on file at and available from Engineering Practices and Standards (EPS).

**2. APPLICABLE DOCUMENTS**

The following TE Connectivity (TE) documents form a part of this specification to the extent specified herein. In the event of conflict between the requirements of this specification and the product drawing, the product drawing shall take precedence. In the event of conflict between the requirements of this specification and the referenced documents, this specification shall take precedence.

- 109-1: Test Specification (General Requirements for Test Specifications)
- 109 Series: Test Specifications as indicated in Figure 1
- 114-40038: Application Specification (AMP-LATCH\* 2 mm Receptacle Connectors)
- 501-254: Qualification Test Report (2 mm AMP-LATCH\* Ribbon Cable Receptacle Connector)

**3. REQUIREMENTS**

## 3.1. Design and Construction

Product shall be of the design, construction and physical dimensions specified on the applicable product drawing.

## 3.2. Materials

Materials used in the construction of this product shall be as specified on the applicable product drawing.

3.3. Ratings

- Voltage: 125 volts AC
- Current: .5 ampere, signal applications

**NOTE** *Continuous maximum rating for individual contacts cannot be applied simultaneously to all contacts as physical and thermal material properties may be exceeded. System design shall ensure that currents applied during steady state or transient conditions do not create internal hot spots that exceed temperature designated by the connector specification.*

- Temperature: -65 to 105°C

3.4. Performance and Test Description

Product is designed to meet the electrical, mechanical and environmental performance requirements specified in Figure 1. Unless otherwise specified, all tests are performed at ambient environmental conditions per Test Specification 109-1.

3.5. Test Requirements and Procedures Summary

Test Description	Requirement	Procedure
Examination of product.	Meets requirements of product drawing and Application Specification 114-40038.	Visual, dimensional and functional per applicable quality inspection plan.
<b>ELECTRICAL</b>		
Termination resistance, dry circuit.	25 milliohms maximum.	TE Spec 109-6-6. Subject mated contacts assembled in housing to 20 millivolt open circuit at 100 milliamperes. See Figure 4.
Dielectric withstanding voltage.	1 minute hold with no breakdown or flashover.	TE Spec 109-29-1. 300 volts AC (rms). Test between adjacent contacts of unmated connector assemblies.
Insulation resistance.	5000 megohms minimum initial. 1000 megohms minimum final.	TE Spec 109-28-3. Test between adjacent contacts of unmated connector assemblies.
<b>MECHANICAL</b>		
Vibration, random.	No discontinuities greater than 1 microsecond. See Note.	TE Spec 109-21-5. Subject mated connectors to 23.91 G's rms for 15 minutes. See Figure 5.
Physical shock.	No discontinuities greater than 1 microsecond. See Note.	TE Spec 109-26-7. Subject mated connectors to 50 G's sawtooth shock pulses of 11 milliseconds duration. 3 shocks in each direction applied along 3 mutually perpendicular planes, 18 total shocks. See Figure 5.

Figure 1 (continued)

Test Description	Requirement	Procedure
Mating force.	1.67 N [6 ozf] maximum per contact.	TE Spec 109-42, Condition A. Measure force necessary to mate connector assemblies with locking latches a distance of 4 mm [.157 in] from the point of initial contact using free floating fixtures at rate of 2.54 cm [1 in] per minute.
Unmating force.	0.14N [0.5 ozf] minimum per contact.	TE Spec 109-42, Condition A. Measure force necessary to unmate connector assemblies with locking latches removed or released at rate of 2.54 cm [1 in] per minute.
Durability.	See Note.	TE Spec 109-27. Mate and unmate connector assemblies for 150 cycles at rate of 150 cycles per hour.
<b>ENVIRONMENTAL</b>		
Thermal shock.	See Note.	TE Spec 109-22. Unless limited by temperature rating of cable used, subject mated connectors to 5 cycles between -65 and 105°C.
Humidity/temperature cycling.	See Note.	TE Spec 109-23-3, Condition B. Subject mated connectors to 10 humidity-temperature cycles between 25 and 65°C at 95% RH.
Mixed flowing gas.	See Note.	TE Spec 109-85-2. Subject mated connectors to environmental Class III for 20 days.
Temperature life.	See Note.	TE Spec 109-43. Subject mated connectors to a temperature of 105°C for 96 hours.

**NOTE**

*Shall meet visual requirements, show no physical damage, and shall meet the requirements of additional tests as specified in the Product Qualification Test Sequence in Figure 2.*

Figure 1 (end)

3.6. Product Qualification and Requalification Test Sequence

Test or Examination	Test Group (a)				
	1	2	3	4	5
	Test Sequence (b)				
Examination of product	1,9	1,5	1,5	1,8	1,5
Termination resistance, dry circuit	3,7	2,4	2,4		2,4
Dielectric withstanding voltage				3,7	
Insulation resistance				2,6	
Vibration	5				
Physical shock	6				
Mating force	2				
Unmating force	8				
Durability	4				
Thermal shock				4	3
Humidity/temperature cycling				5	
Mixed flowing gas			3(c)		
Temperature life		3(c)			

- NOTE**
- (a) See paragraph 4.1.A.
  - (b) Numbers indicate sequence in which tests are performed.
  - (c) Precondition samples with 5 durability cycles.

Figure 2

#### 4. QUALITY ASSURANCE PROVISIONS

##### 4.1. Qualification Testing

###### A. Sample Selection

Connector housings and contacts shall be prepared in accordance with applicable Instruction Sheets and shall be selected at random from current production. Test groups shall consist of samples per Figure 3. Test connectors shall be terminated midway along cable with additional outboard connectors applied to facilitate automated data readout per applicable Application Specifications.

Description	Test Group				
	1	2	3	4	5
Connector quantity	6	5	4	10	5
Contact quantity (minimum)	48	200	160	80	200
Connector size (reference)	8 max	40 min	40 min	8 min	40 min
Recommended cable length (cm)	76	30	30	NA	30

Figure 3

###### B. Test Sequence

Qualification inspection shall be verified by testing samples as specified in Figure 2.

##### 4.2. Requalification Testing

If changes significantly affecting form, fit or function are made to the product or manufacturing process, product assurance shall coordinate requalification testing, consisting of all or part of the original testing sequence as determined by development/product, quality and reliability engineering.

##### 4.3. Acceptance

Acceptance is based on verification that product meets the requirements of Figure 1. Failures attributed to equipment, test setup or operator deficiencies shall not disqualify the product. When product failure occurs, corrective action shall be taken and samples resubmitted for qualification. Testing to confirm corrective action is required before resubmittal.

##### 4.4. Quality Conformance Inspection

The applicable quality inspection plan will specify the sampling acceptable quality level to be used. Dimensional and functional requirements shall be in accordance with the applicable product drawing and this specification.

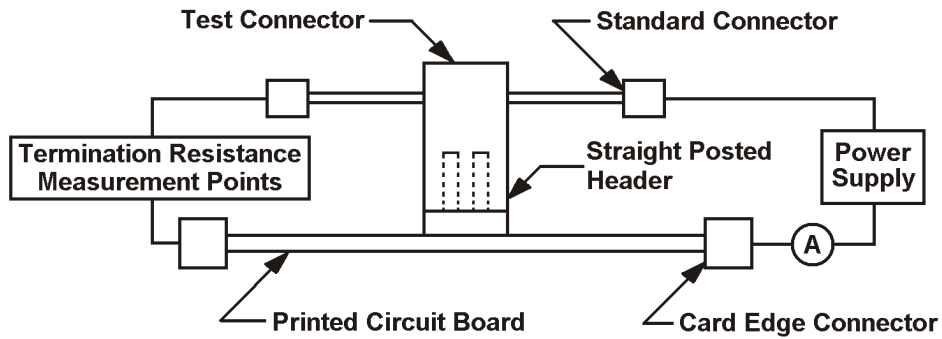
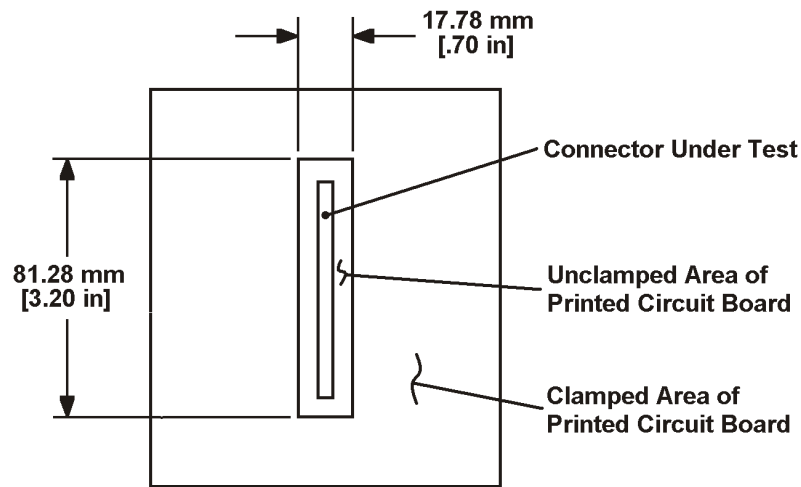
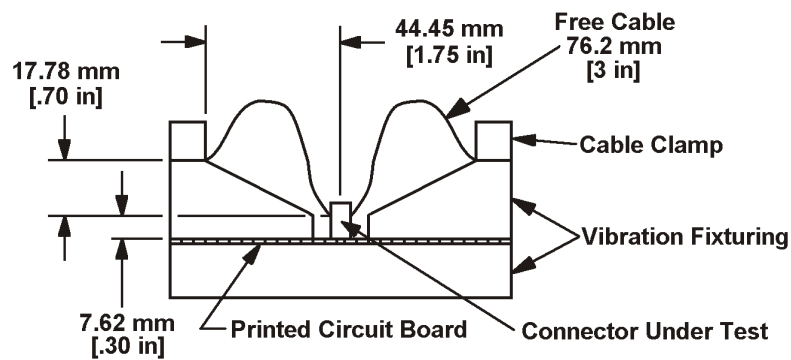

Figure 4  
Termination Resistance & Temperature Measurement Points



Top View



Side View

Figure 5  
Mounting & Clamping Location For Vibration & Physical Shock