

4

3

2

1

THIS DRAWING IS UNPUBLISHED. RELEASED FOR PUBLICATION AUG 2006  
 © COPYRIGHT BY TYCO ELECTRONICS CORPORATION. ALL RIGHTS RESERVED.

LOC	DIST	REVISIONS			
P	LTR	DESCRIPTION	DATE	DWN	APVD
DW		SEE SHEET 1.			

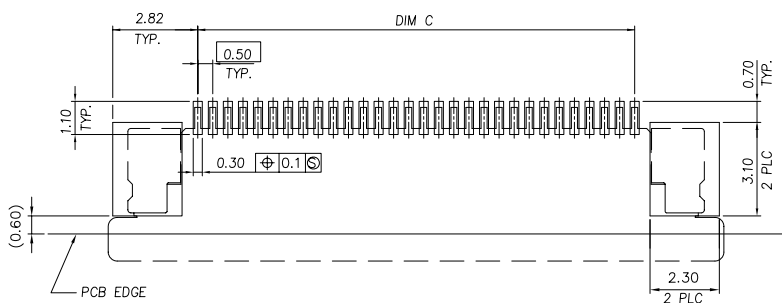

RECOMMENDED PCB DIMENSIONS DIAGRAM  
 TOLERANCE: ±0.05

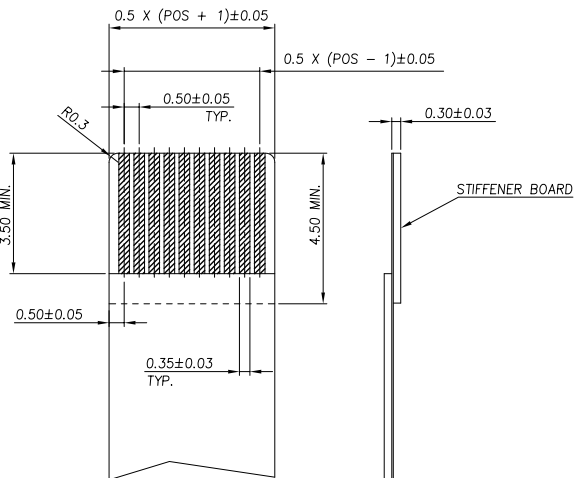

RECOMMENDED FPC DIMENSIONS DIAGRAM

THIS DRAWING IS A CONTROLLED DOCUMENT.		DWN	<b>TE</b> TE Connectivity		
DIMENSIONS: MM		CHK			
TOLERANCES UNLESS OTHERWISE SPECIFIED:		APVD	NAME		
0 PLC ± -		PRODUCT SPEC	FPC CONNECTOR, 0.5mm PITCH, TOP CONTACT, SMT TYPE.		
1 PLC ± -		APPLICATION SPEC	SIZE	CAGE CODE	DRAWING NO
2 PLC ± -		MATERIAL	A3	00779	C=1734839
3 PLC ± -		FINISH	CUSTOMER DRAWING		
4 PLC ± -		WEIGHT	SCALE	SHEET	REV
ANGLES ± -				2 of 3	B

THIS DRAWING IS UNPUBLISHED. RELEASED FOR PUBLICATION AUG. 2006.  
 © COPYRIGHT BY TYCO ELECTRONICS CORPORATION. ALL RIGHTS RESERVED.

LOC	DIST	REVISIONS			
P	LTR	DESCRIPTION	DATE	DWN	APVD
DW		SEE SHEET 1.			

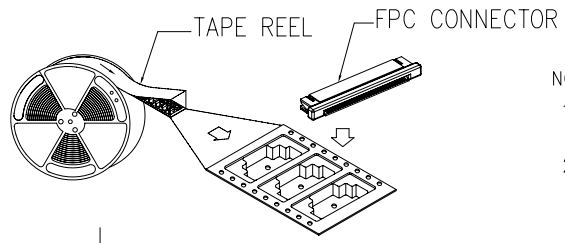
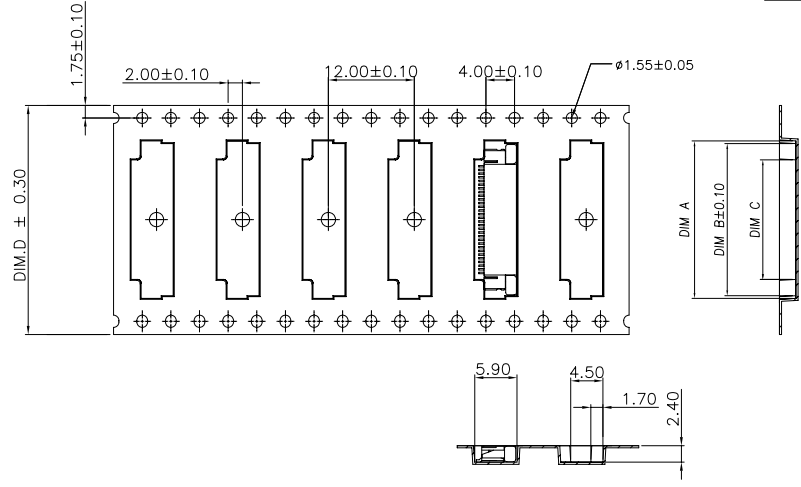

- NOTE :
- TAPE REEL:  
DIAMETER: 13", THICKNESS : 0.35±0.05mm.
  - CARTON:  
SIZE: 350mm(L)X 350mm(W)X 340mm(H).
  - WEIGHT:  
NET WEIGHT: 7.5kg  
GROSS WEIGHT: 13.4kg

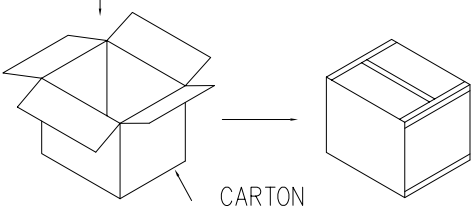

QTY	APQ	PPQ	D	C	B	A	POS.	PART NUMBER
44.00	26.70	30.55	31.50	50				5-1734839-0
44.00	26.20	30.05	31.00	49				4-1734839-9
44.00	25.70	29.55	30.50	48				4-1734839-8
44.00	25.20	29.05	30.00	47				4-1734839-7
44.00	24.70	28.55	29.50	46				4-1734839-6
44.00	24.20	28.05	29.00	45				4-1734839-5
44.00	23.70	27.55	28.50	44				4-1734839-4
44.00	23.20	27.05	28.00	43				4-1734839-3
44.00	22.70	26.55	27.50	42				4-1734839-2
44.00	22.20	26.05	27.00	41				4-1734839-1
44.00	21.70	25.55	26.50	40				4-1734839-0
44.00	21.20	25.05	26.00	39				3-1734839-9
44.00	20.70	24.55	25.50	38				3-1734839-8
44.00	20.20	24.05	25.00	37				3-1734839-7
44.00	19.70	23.55	24.50	36				3-1734839-6
44.00	19.20	23.05	24.00	35				3-1734839-5
44.00	18.70	22.55	23.50	34				3-1734839-4
44.00	18.20	22.05	23.00	33				3-1734839-3
44.00	17.70	21.55	22.50	32				3-1734839-2
44.00	17.20	21.05	22.00	31				3-1734839-1
32.00	16.70	20.55	21.50	30				3-1734839-0
32.00	16.20	20.05	21.00	29				2-1734839-9
32.00	15.70	19.55	20.50	28				2-1734839-8
32.00	15.20	19.05	20.00	27				2-1734839-7
32.00	14.70	18.55	19.50	26				2-1734839-6
32.00	14.20	18.05	19.00	25				2-1734839-5
32.00	13.70	17.55	18.50	24				2-1734839-4
32.00	13.20	17.05	18.00	23				2-1734839-3
32.00	12.70	16.55	17.50	22				2-1734839-2
32.00	12.20	16.05	17.00	21				2-1734839-1
24.00	11.70	15.55	16.50	20				2-1734839-0
24.00	11.20	15.05	16.00	19				1-1734839-9
24.00	10.70	14.55	15.50	18				1-1734839-8
24.00	10.20	14.05	15.00	17				1-1734839-7
24.00	9.70	13.55	14.50	16				1-1734839-6
24.00	9.20	13.05	14.00	15				1-1734839-5
24.00	8.70	12.55	13.50	14				1-1734839-4
24.00	8.20	12.05	13.00	13				1-1734839-3
24.00	7.70	11.55	12.50	12				1-1734839-2
24.00	7.20	11.05	12.00	11				1-1734839-1
24.00	6.70	10.55	11.50	10				1-1734839-0
24.00	6.20	10.05	11.00	09				0-1734839-9
24.00	5.70	9.55	10.50	08				0-1734839-8
24.00	5.20	9.05	10.00	07				0-1734839-7
24.00	4.70	8.55	9.50	06				0-1734839-6
24.00	4.20	8.05	9.00	05				0-1734839-5

THIS DRAWING IS A CONTROLLED DOCUMENT.		DWN		
DIMENSIONS: MM		CHK		
TOLERANCES UNLESS OTHERWISE SPECIFIED:		APVD		
0 PLC	±	PRODUCT SPEC		
1 PLC	±	APPLICATION SPEC		
2 PLC	±	WEIGHT		
3 PLC	±			
4 PLC	±			
ANGLES	±			
MATERIAL	FINISH			
		NAME	FPC CONNECTOR, 0.5mm PITCH, TOP CONTACT, SMT TYPE.	
		SIZE	CAGE CODE	DRAWING NO
			A3	00779 ©=1734839
		CUSTOMER DRAWING	SCALE	SHEET 3 OF 3 REV B

