

DRAWING MADE IN THIRD ANGLE PROJECTION
 THIS DRAWING IS UNPUBLISHED. RELEASED FOR PUBLICATION .19
 © COPYRIGHT 19 BY AMP INCORPORATED. ALL INTERNATIONAL RIGHTS RESERVED.

PROD CODE		LOC	DIST	REVISIONS				DATE	APPD
4092	DF	50	P	F	ZONE	LTR	DESCRIPTION	4-90	DF
						N	REV & REDRAWN PER DF-2559	CT	
						P	REV PER 0600-4150-95	CT	8-95
									DE

PART NO.	A	
830614-1	24.00	[609.6]
830614-2	12.00	[304.8]
830614-3	18.00	[457.2]
830614-4	120.00	[3048.0]
830614-5	12.50	[317.5]
830614-6	16.00	[406.4]
830614-7	13.25	[336.5]
830614-8	8.50	[215.9]
830614-9	9.50	[241.3]
1-830614-0	10.00	[254.0]
1-830614-1	14.50	[368.3]
1-830614-2	5.00	[127.0]
1-830614-3	72.00	[1828.8]
1-830614-4	60.00	[1524.0]
1-830614-5	6.00	[152.4]
1-830614-6	36.00	[914.4]
1-830614-7	660.00	[16764.0]
1-830614-8	8.12	[206.2]
1-830614-9	80.00	[2032.0]
2-830614-0	39.38	[1000.3]
2-830614-1	354.31	[8999.5]
2-830614-2	708.62	[17998.9]
2-830614-3	6.50	[165.1]
2-830614-4	14.00	[355.6]
2-830614-5	48.00	[1219.2]
2-830614-6	30.00	[762.0]
2-830614-7	40.00	[1016.0]

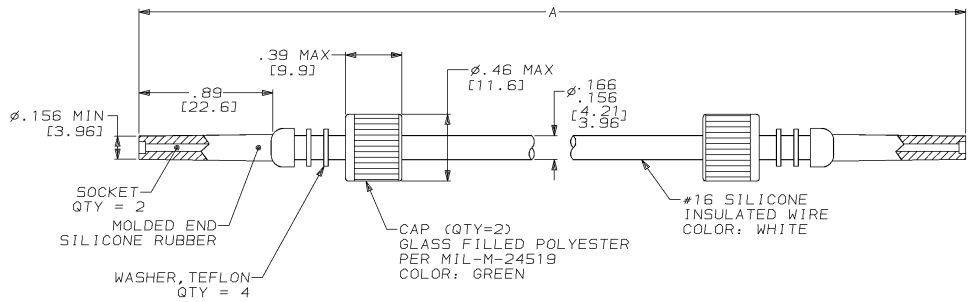

- △ TOLERANCE OF LEAD LENGTH:
 UP TO 24 INCHES [609.6] = ±.12 [±3.0]
 24 INCHES [609.6] & UP = ±1%
- MARKED PER MIL-STD-130.
 - TO MATE WITH AMP LGH-1/2 RECEPTACLE WITH .89 [22.6] BARREL DEPTH.
 - OPERATING VOLTAGE: 15 KVDC AT 0 TO 70,000 FEET, -55°C TO 125°C.
 - MIN LEAD LENGTH IS 5 INCHES [127.0].

DO NOT SCALE PRINT. UNLESS SPECIFIED DIMENSIONS IN INCHES [mm] TOLERANCES ON: 2 PLC DEC ±.02 [0.5] 3 PLC DEC ± ANGLES ±	DR 12-14-89 C.C. THOMAS	AMP INCORPORATED Harrisburg, Pa. 17105	
MATERIAL SEE CALLOUTS	CHK 4-27-90 D.EABY		
FINISH	APPD 4-27-90 C.C. THOMAS	SIZE C	CAGE CODE 00779
WEIGHT	APPLICATION SPEC	DRAWING NO 830614	SHEET 1 OF 1

CUSTOMER DRAWING