

---

**EP II Connector System**

---

**DESIGN OBJECTIVES**

The product described in this document has not been fully tested to ensure conformance to the requirements outlined below. Therefore, TE Connectivity (TE) makes no representation or warranty, express or implied, that the product will comply with these requirements. Further, TE may change these requirements based on the results of additional testing and evaluation. Contact TE Engineering for further details.

**1. SCOPE**

## 1.1. Content

This specification covers performance, tests and quality requirements for the TE Connectivity (TE) Economy Power (EP) II Connector System used for wire-to-board interconnection and mates with EP headers.

## 1.2. Qualification

When tests are performed on the subject product line, procedures specified in Figure 1 shall be used. All inspections shall be performed using the applicable inspection plan and product drawing.

**2. APPLICABLE DOCUMENTS**

The following documents form a part of this specification to the extent specified herein. Unless otherwise specified, the latest edition of the document applies. In the event of conflict between the requirements of this specification and the product drawing, the product drawing shall take precedence. In the event of conflict between the requirements of this specification and the referenced documents, this specification shall take precedence.

## 2.1. Tyco Electronics Documents

- 114-13265: Application Specification (Economy Power II Contacts and Connectors)
- 501-TBD: Qualification Test Report (EP II Connector System)

## 2.2. Industry Document

EIA-364: Electrical Connector/Socket Test Procedures Including Environmental Classifications

## 2.3. Reference Document

109-197: Test Specification (AMP Test Specifications vs EIA and IEC Test Methods)

**3. REQUIREMENTS**

## 3.1. Design and Construction

Product shall be of the design, construction and physical dimensions specified on the applicable product drawing.

## 3.2. Materials

Materials used in the construction of this product shall be as specified on the applicable product drawing.

PRELIMINARY

3.3. Ratings

- Voltage: 600 volts AC
- Current: See Figure 4 for applicable current carrying capability. Maximum rated current that can be carried by this product is limited by maximum operating temperature of the housings (105°C) and temperature rise of the housings (30°C). Variables to be considered for each application are: wire size, connector size, contact material, ambient temperature, and printed circuit board design.
- Temperature: -55 to 105°C

3.4. Performance and Test Description

Product is designed to meet the electrical, mechanical and environmental performance requirements specified in Figure 1. Unless otherwise specified, all tests shall be performed at ambient environmental conditions.

3.5. Test Requirements and Procedures Summary

Test Description	Requirement	Procedure
Initial examination of product.	Meets requirements of product drawing and Application Specification 114-13265.	EIA-364-18. Visual and dimensional (C of C) inspection per product drawing.
Final examination of product.	Meets visual requirements.	EIA-364-18. Visual inspection.
<b>ELECTRICAL</b>		
Low Level Contact Resistance (LLCR).	10 milliohms maximum initial. 20 milliohms maximum final.	EIA-364-23. Subject specimens to 100 milliamperes maximum and 20 millivolts maximum open circuit voltage. See Figure 3.
Insulation resistance.	1000 megohms minimum initial. 500 megohms minimum final.	EIA-364-21. 500 volts DC, 2 minute hold. Test between adjacent contacts.
Withstanding voltage.	One minute hold with no breakdown or flashover.	EIA-364-20, Condition I. 1500 volts AC at sea level. Test between adjacent contacts.
Temperature rise vs current.	30°C maximum temperature rise at specified current.	EIA-364-70, Method 1. Stabilize at a single current level until 3 readings at 5 minute intervals are within 1°C. See Figure 4.
<b>MECHANICAL</b>		
Random vibration.	No discontinuities of 1 microsecond or longer duration. See Note.	EIA-364-28, Test Condition VII, Condition Letter D. Subject mated specimens to 3.10 G's rms between 20 to 500 Hz. Fifteen minutes in each of 3 mutually perpendicular planes.

Figure 1 (continued)

**DESIGN OBJECTIVES 07Sep11**

Test Description	Requirement	Procedure										
Mechanical shock.	No discontinuities of 1 microsecond or longer duration. See Note.	EIA-364-27, Condition H. Subject mated specimens to 30 G's half-sine shock pulses of 11 milliseconds duration. Three shocks in each direction applied along 3 mutually perpendicular planes, 18 total shocks.										
Durability.	See Note.	EIA-364-9. Mate and unmate specimens for 15 cycles at a maximum rate of 500 cycles per hour.										
Mating force.	9.8 N [2.2 lbf] maximum per contact.	EIA-364-13. Measure force necessary to mate specimens with latches disengaged at a maximum rate of 12.7 mm per minute.										
Unmating force.	0.9 N [0.22 lbf] minimum per contact.	EIA-364-13. Measure force necessary to unmate specimens with latches disengaged at a maximum rate of 12.7 mm per minute.										
Crimp tensile.	<table border="1"> <thead> <tr> <th>Wire Size (AWG)</th> <th>Crimp Tensile N [lbf] Minimum</th> </tr> </thead> <tbody> <tr> <td>22</td> <td>44.5 [10]</td> </tr> <tr> <td>20</td> <td>62.3 [14]</td> </tr> <tr> <td>18</td> <td>75.6 [17]</td> </tr> <tr> <td>16</td> <td>120 [27]</td> </tr> </tbody> </table>	Wire Size (AWG)	Crimp Tensile N [lbf] Minimum	22	44.5 [10]	20	62.3 [14]	18	75.6 [17]	16	120 [27]	EIA-364-8. Determine crimp tensile at a rate of 25.4 mm per minute.
Wire Size (AWG)	Crimp Tensile N [lbf] Minimum											
22	44.5 [10]											
20	62.3 [14]											
18	75.6 [17]											
16	120 [27]											
Contact retention.	29.4 N [6.6 lbf] minimum per contact.	EIA-364-29. Apply axial load at a rate of 4.4 N per second and hold for 6 seconds.										

ENVIRONMENTAL

Thermal shock.	See Note.	EIA-364-32, Test Condition VII. Subject specimens to 10 cycles between -55 and 105°C with 30 minute dwells at temperature extremes.
Humidity/temperature cycling.	See Note.	EIA-364-31, Method III. Subject specimens to 10 cycles (10 days) between 25 and 65°C at 80 to 100% RH.
Temperature life.	See Note.	EIA-364-17, Method A, Test Condition 4, Test Time Condition C. Subject mated specimens to 105°C for 500 hours.

**NOTE**

*Shall meet visual requirements, show no physical damage, and meet requirements of additional tests as specified in the Product Qualification and Requalification Test Sequence shown in Figure 2.*

Figure 1 (end)

3.6. Product Qualification and Requalification Test Sequence

Test or Examination	Test Group (a)			
	1	2	3	4
	Test Sequence (b)			
Initial examination of product	1	1	1	1
LLCR	3,7	2,6		
Insulation resistance			2,5	
Withstanding voltage			3,6	
Temperature rise vs current		3		
Random vibration	5			
Mechanical shock	6			
Durability	4			
Mating force	2			
Unmating force	8			
Crimp tensile				2
Contact retention			7	
Thermal shock			4	
Humidity/temperature cycling		4(c)		
Temperature life		5(c)		
Final examination of product	9	7	8	3

- NOTE**
- (a) See paragraph 4.1.A.
  - (b) Numbers indicate sequence in which tests are performed.
  - (c) Precondition specimens with 10 durability cycles.

Figure 2

**4. QUALITY ASSURANCE PROVISIONS**

4.1. Qualification Testing

A. Specimen Selection

Specimens shall be prepared in accordance with applicable Instruction Sheets and shall be selected at random from current production. Each test group shall consist of a minimum of 5 specimens.

B. Test Sequence

Qualification inspection shall be verified by testing specimens as specified in Figure 2.

4.2. Requalification Testing

If changes significantly affecting form, fit or function are made to the product or manufacturing process, product assurance shall coordinate requalification testing, consisting of all or part of the original testing sequence as determined by development/product, quality and reliability engineering.

4.3. Acceptance

Acceptance is based on verification that the product meets the requirements of Figure 1. Failures attributed to equipment, test setup or operator deficiencies shall not disqualify the product. If product failure occurs, corrective action shall be taken and specimens resubmitted for qualification. Testing to confirm corrective action is required before resubmittal.

4.4. Quality Conformance Inspection

The applicable quality inspection plan shall specify the sampling acceptable quality level to be used. Dimensional and functional requirements shall be in accordance with the applicable product drawing and this specification.

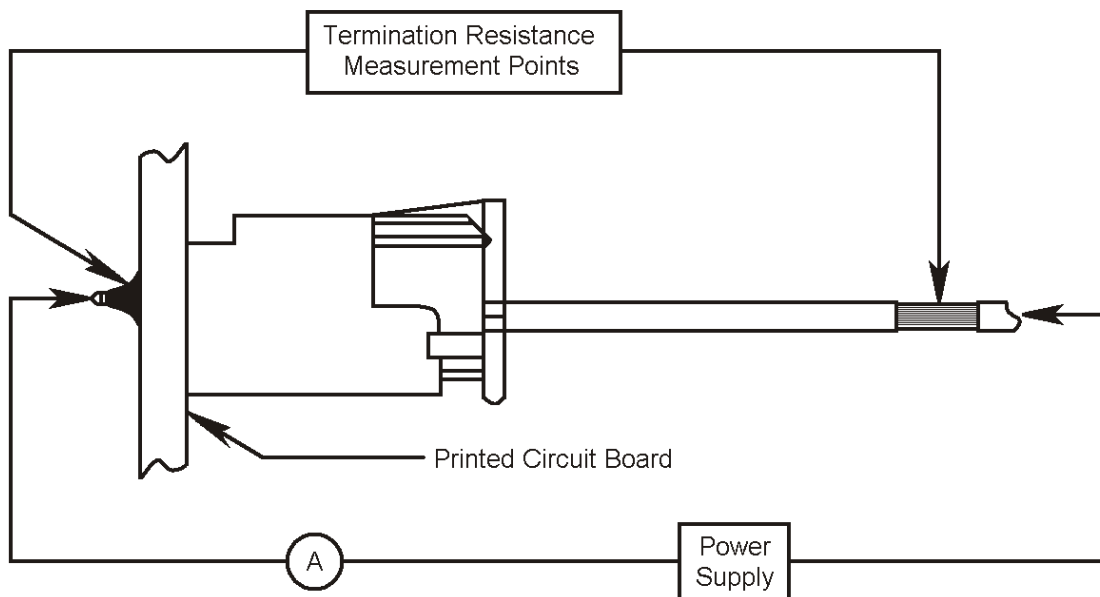

Figure 3  
LLCR Measurement Points

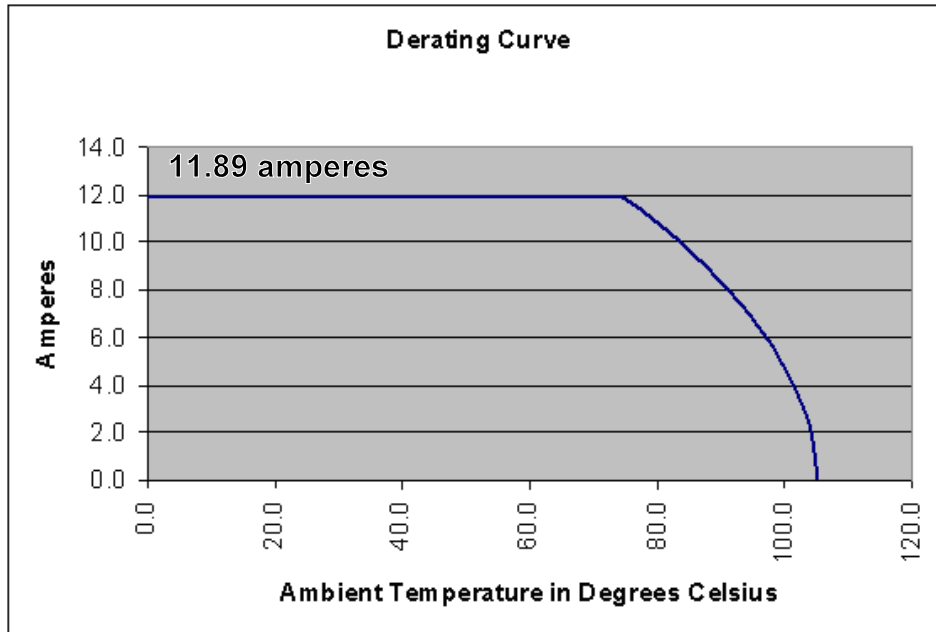

Figure 4A  
Current Carrying Capability

Percent Connector Loading	Wire Size AWG			
	16	18	20	22
Single Contact	1.0	0.869	0.767	0.685
50	0.786	0.683	0.603	0.538
100	0.587	0.510	0.450	0.402

**NOTE** To determine acceptable current carrying capacity for percentage connector loading and wire gage indicated, use the Multiplication Factor (F) from the above chart and multiply it times the Base rated Current for a single circuit at the maximum ambient operating temperature shown in Figure 4A.

Figure 4B  
Current Rating