

4

3

2

1

THIS DRAWING IS UNPUBLISHED. RELEASED FOR PUBLICATION
 © COPYRIGHT - BY TYCO ELECTRONICS CORPORATION. ALL RIGHTS RESERVED.

LOC	DIST	REVISIONS				
P	LTR	DESCRIPTION	DATE	DWN	APVD	
CM	00					
	C	ECO-08-001888	28JAN08	KW	DB	
	C1	REVISED PER ECO-09-023313	13OCT09	KK	AEG	

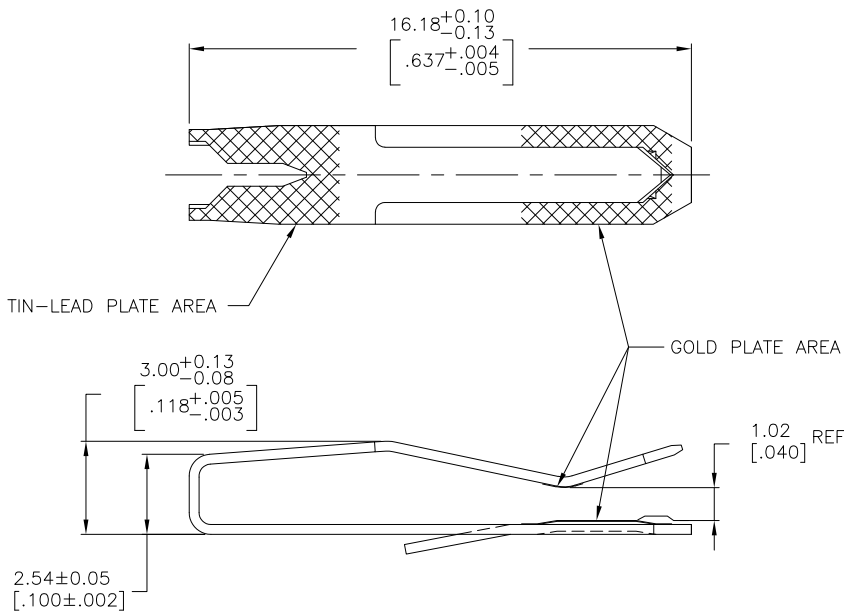

- DIMENSIONS IN BRACKETS ARE IN INCHES.
- 0.00038 [.000015] MIN THICK GOLD IN THE GOLD PLATE AREA OVER 0.00127 [.000050] MIN THICK NICKEL.
- 0.00076 [.000030] MIN THICK GOLD IN THE GOLD PLATE AREA OVER 0.00127 [.000050] MIN THICK NICKEL.
- 0.00203 [.000080] MIN THICK TIN-LEAD IN THE TIN-LEAD PLATE AREA OVER 0.00127 [.000050] MIN THICK NICKEL.
- MATTE TIN 0.00203(.000080) MIN THICK IN TIN PLATED AREA
- OBsolete PARTS: OBsolete CIS STREAMLINING PER D.RENAUD/D.SINISI

△3	△5	641144-4		
△2	△5	641144-3		
△3	△4	641144-2		
△6	SUPERSEDED	△2	△4	641144-1
FINISH		PART NO		

METRIC

THIS DRAWING IS A CONTROLLED DOCUMENT.		DWN	25OCT2005	Tyco Electronics		Tyco Electronics Corporation Harrisburg, PA 17105-3608	
DIMENSIONS: mm [INCHES]		CHK	25OCT2005	NAME		CONTACT, GOLD STRIPE, 20 AWG WIRE, LOOSE PIECE, MTA 156	
TOLERANCES UNLESS OTHERWISE SPECIFIED:		APVD	25OCT2005	PRODUCT SPEC		APPLICATION SPEC	
0 PLC ± -				SIZE		CAGE CODE	
1 PLC ± -				WEIGHT		DRAWING NO	
2 PLC ± -				A3		00779	
3 PLC ± 0.13 [.005]				C-641144		RESTRICTED TO	
4 PLC ± -				CUSTOMER DRAWING		SCALE	
ANGLES ± -				8:1		SHEET	
FINISH		SEE TABLE		1 of 1		REV	
MATERIAL		0.30 [.012] THK COPPER ALLOY		C1			

AMP 1470-19 REV 31MAR2000