

NUMBER C-176764-2
 3rd ANGLE PROJECTION
 METRIC
 PROJ. NO. 691-231
 DIMENSIONS IN MILLIMETERS. DO NOT SCALE PRINT
 PRINT DIST

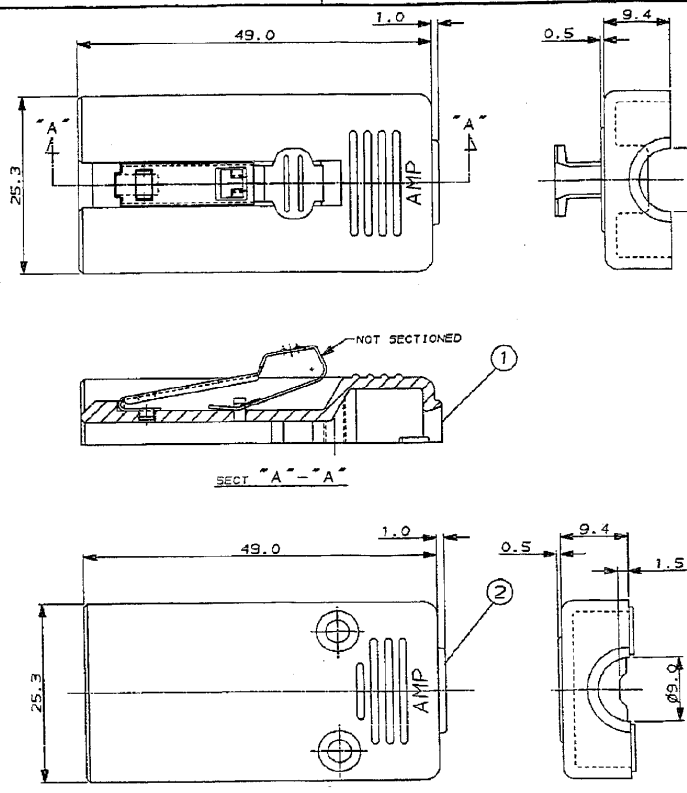

NOTES;
 1 APPLICABLE SPECIFICATIONS
 PRODUCT SPEC. : 108-5315
 APPLICATION SPEC. : 114-5147
 2 INSTRUCTION SHEET: IS-507J

注記;
 1 適用規格
 製品規格 : 108-5315
 取付適用規格 : 114-5147
 2 取扱説明書 : IS-507J

2	STEEL, ZINC PLATED スチール、亜鉛メッキ	TAP-TYPE B-TYPE M2.6 SCREW M2.6 タップタイト Bタイプ	900035-1	(5)
2	STEEL, ZINC PLATED スチール、亜鉛メッキ	TAP-TYPE P-TYPE M3 M3 タップタイト Pタイプ	900034-1	(4)
1	STEEL, ZINC PLATED スチール、亜鉛メッキ	CLAMP クランプ	176832-1	(3)
1	THERMAL PLASTIC (94-HD), COLOR: ART GRAY S.S. 熱可塑性樹脂 (94-HD), 色: アートグレー S.S.	COVER "B" 12POS カバー "B" 12極	178930-1	(2)
1	THERMAL PLASTIC (94-HD), COLOR: ART GRAY S.S. 熱可塑性樹脂 (94-HD), 色: アートグレー S.S.	COVER "A" WITH LOCK LEVER 12POS カバー "A" ロックレバー付 12極	178933-1	(1)
QTY	材料及び仕上 MATERIAL & FINISH	名称 NAME	型番 P/N	ITEM NO.

Copyright © 1991
 AMP (Japan) LTD.
 ALL RIGHTS RESERVED.

AMP AMP (JAPAN), LTD.
 Tokyo, Japan

WIRE RANGE: ——— mm (AWG — —)
 INSULATION DIA: ——— mm
 NAME: アンペア ラテイス コネクタ
 ケーブル クランプ キット 12極
 AMP LATTICE CONN. CABLE CLAMP KIT 12POS

GENERAL TOLERANCE	SIZE	LOC	NUMBER
B	J	C	C-176764-2
SCALE	REV.	SHEET	
2-1	C	1 OF 2	

DR: T. FUTATSUGI
 18-NOV-'91
 APP. Y. TANABE

LTR REVISION RECORD DR CHK DATE

CUSTOMER DRAWING

NUMBER
C-176764-2

3-2 ANGLE PROJECTION

METRIC

PRINT DIST

REV. 10/83

PROJ. NO. 399-355

DIMENSIONS IN MILLIMETERS, DO NOT SCALE PRINT

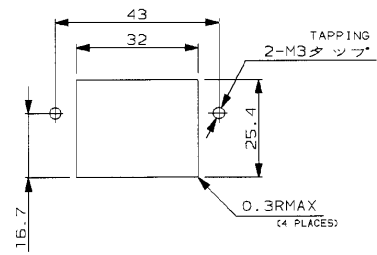
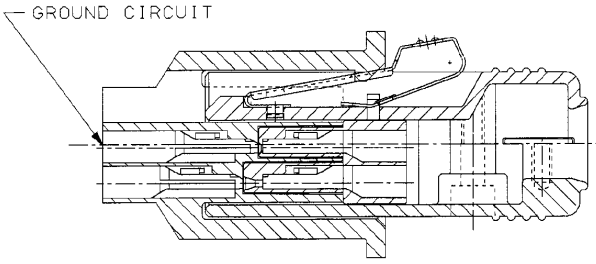
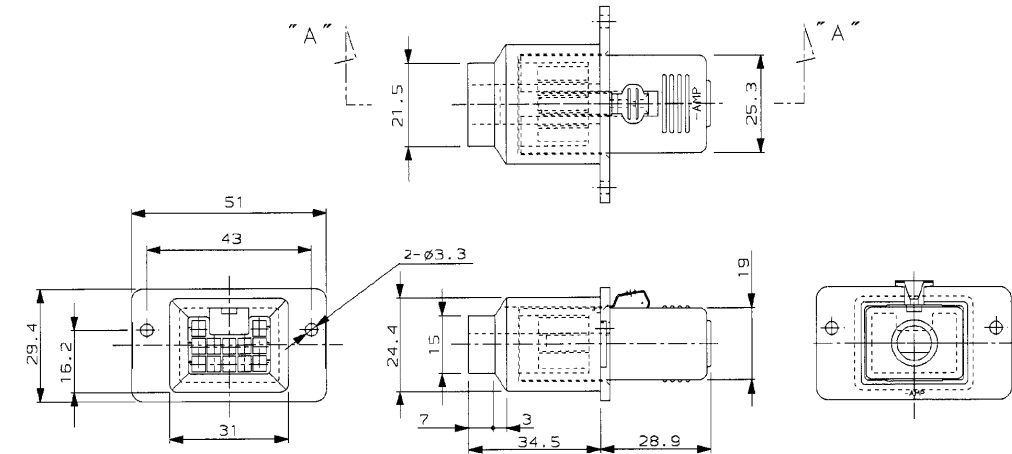

パネル取付寸法
PANEL CUT OUT DIMENSION

SECT "A"-"A"
(SCALE 2-1)

SEE SHEET 1 OF 2			
LTR	REVISION RECORD	DR	CHK DATE

WIRE RANGE --- mm ² (AWG -)		INSULATION DIA --- mmφ	
MATERIAL		FINISH	
DR.		DE.	
APP.			

Copyright © 1991 AMP (Japan) LTD. ALL RIGHTS RESERVED.		AMP AMP (JAPAN), LTD. Tokyo, Japan	
NAME アンパ ラティス コネクター 12極 嵌合状態図 AMP LATTICE CONNECTOR 12POS.			
GENERAL TOLERANCE		SIZE	LOC NUMBER
0<<< 10 : ±0.2 10<<< 30 : ±0.25 30<<< 100 : ±0.3 ANGLES : ±3°		B J	C-176764-2
SCALE	REV.	SHEET	
1-1	C	2 OF 2	

CUSTOMER DRAWING