

4

3

2

1

THIS DRAWING IS UNPUBLISHED. RELEASED FOR PUBLICATION
 © COPYRIGHT BY TYCO ELECTRONICS CORPORATION. ALL RIGHTS RESERVED.

LOC		DIST		REVISIONS			
P	LTR	DESCRIPTION	DATE	DWN	APVD		
	R	REDRAWN PER 0G3A-0181-01	14MAR01	JR	ND		

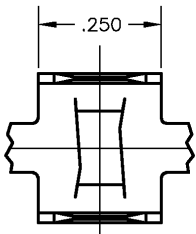

1 CONTINUOUS STRIP ON REELS
 △ .000150 MIN TIN PLATE OVER
 .000100 MIN COPPER.

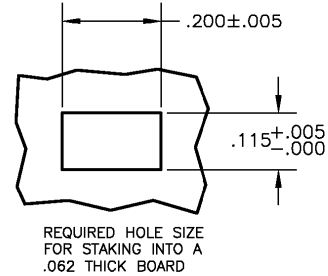
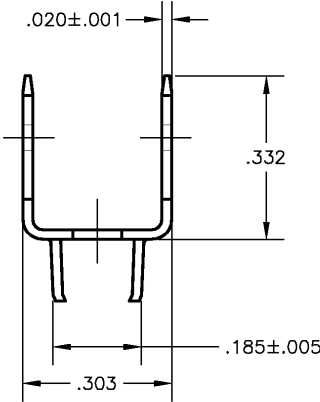
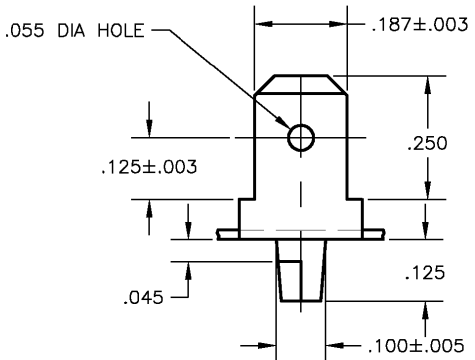

62221-1
 PART NO.

THIS DRAWING IS A CONTROLLED DOCUMENT.		DWN JR RUTH 14MAR01	Tyco Electronics Corporation Harrisburg, PA. 17057	
DIMENSIONS: INCHES	TOLERANCES UNLESS OTHERWISE SPECIFIED:	G/K MS FEHER 14MAR01	NAME	
	0 PLC ± -	APVD N DEIBERT 14MAR01	TAB, FASTON, DUAL, STAKE, .187 SERIES	
	1 PLC ± -	PRODUCT SPEC	SIZE	RESTRICTED TO
	2 PLC ± -	APPLICATION SPEC	A3	
	3 PLC ± .015	WEIGHT	CAGE CODE	
	4 PLC ± -		00779	
	ANGLES ± -	DRAWING NO	C-62221	
MATERIAL 081 BRASS	FINISH - △	CUSTOMER DRAWING		SCALE 5:1 SHEET 1 OF 1 REV R

AMP 1470-19 REV 31MAR2000
 06MAR01 2:17pm amp13469