

THIS DRAWING IS UNPUBLISHED. RELEASED FOR PURSUIT OF ALL RIGHTS RESERVED.

REV	DATE	DESCRIPTION	BY	CHK
CM 54	7/11/11	REVISED PER ECO-11-004820	11MR11	RK HMR

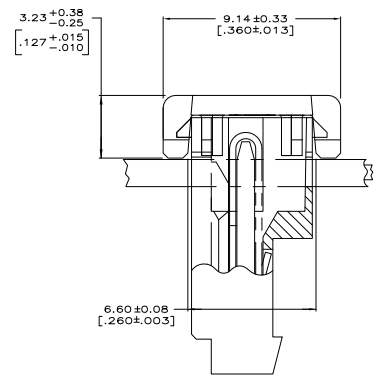

△ PART MAY BE MOLDED TO DESIRED POSITION SIZE OR CUT TO DESIRED POSITION SIZE FROM A LARGER POSITION SIZE PART. WHEN PART IS CUT TO DESIRED POSITION SIZE, A PORTION OF FRONT LOCKING BAR WILL REMAIN ATTACHED.  
2. DIMENSIONS IN BRACKETS ARE IN INCHES.

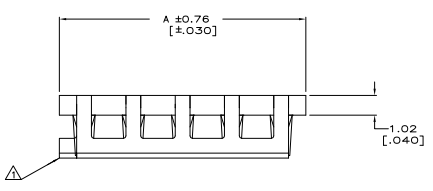
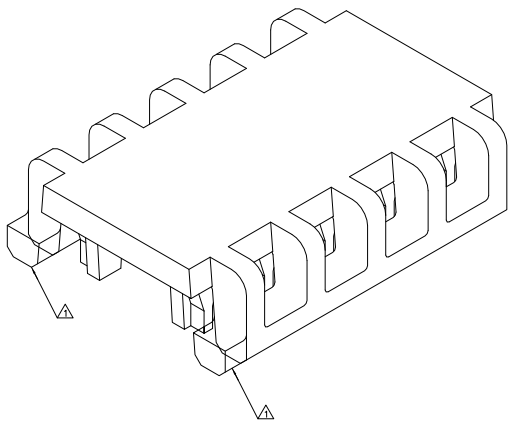

28	CIRCUIT ASSEMBLES	71.12	[2.800]	2-643077-8
27	CIRCUIT ASSEMBLES	68.58	[2.700]	2-643077-7
26	CIRCUIT ASSEMBLES	66.04	[2.600]	2-643077-6
25	CIRCUIT ASSEMBLES	63.50	[2.500]	2-643077-5
24	CIRCUIT ASSEMBLES	60.96	[2.400]	2-643077-4
23	CIRCUIT ASSEMBLES	58.42	[2.300]	2-643077-3
22	CIRCUIT ASSEMBLES	55.88	[2.200]	2-643077-2
21	CIRCUIT ASSEMBLES	53.34	[2.100]	2-643077-1
20	CIRCUIT ASSEMBLES	50.80	[2.000]	2-643077-0
19	CIRCUIT ASSEMBLES	48.26	[1.900]	1-643077-9
18	CIRCUIT ASSEMBLES	45.72	[1.800]	1-643077-8
17	CIRCUIT ASSEMBLES	43.18	[1.700]	1-643077-7
16	CIRCUIT ASSEMBLES	40.64	[1.600]	1-643077-6
15	CIRCUIT ASSEMBLES	38.10	[1.500]	1-643077-5
14	CIRCUIT ASSEMBLES	35.56	[1.400]	1-643077-4
13	CIRCUIT ASSEMBLES	33.02	[1.300]	1-643077-3
12	CIRCUIT ASSEMBLES	30.48	[1.200]	1-643077-2
11	CIRCUIT ASSEMBLES	27.94	[1.100]	1-643077-1
10	CIRCUIT ASSEMBLES	25.40	[1.000]	1-643077-0
9	CIRCUIT ASSEMBLES	22.86	[.900]	643077-9
8	CIRCUIT ASSEMBLES	20.32	[.800]	643077-8
7	CIRCUIT ASSEMBLES	17.78	[.700]	643077-7
6	CIRCUIT ASSEMBLES	15.24	[.600]	643077-6
5	CIRCUIT ASSEMBLES	12.70	[.500]	643077-5
4	CIRCUIT ASSEMBLES	10.16	[.400]	643077-4
3	CIRCUIT ASSEMBLES	7.62	[.300]	643077-3
2	CIRCUIT ASSEMBLES	5.08	[.200]	643077-2

USE ON MTA 100 ASSEMBLIES AS LISTED

THIS DRAWING IS A CONTROLLED DOCUMENT.		REV. 54	DATE 7-11-11
DRAWING NO. 643077		REV. 54	DATE 7-11-11
DRAWING TITLE		REV. 54	DATE 7-11-11
DRAWING SUB-TITLE		REV. 54	DATE 7-11-11
DRAWING SCALE		REV. 54	DATE 7-11-11
DRAWING SHEET NO.		REV. 54	DATE 7-11-11
DRAWING SHEET TOTAL		REV. 54	DATE 7-11-11

STE TE Connectivity  
COVER, FEED-THRU, MOLDED, .060 MAX. O.D. WIRE, MTA-100

DATE 07/11/11 DRAWING NO. A100779 C=643077

CUSTOMER DRAWING