

THIS DRAWING IS UNPUBLISHED. RELEASED FOR PUBLICATION .19
 © COPYRIGHT 19 BY AMP INCORPORATED. ALL INTERNATIONAL RIGHTS RESERVED.

LOC		DIST		ZONE		LTR		REVISIONS		
CH		P	F					DESCRIPTION	DATE	APPD
	11							D ECN96022902 OBSOLETE (PENDING) 192447-3	05/08/96	
								D1 REVISED PER ECO-09-020935	09SEP09	AEQ

- △ FINISH - SILVER PLATE, 200 MIN μINCHES THICK, PER AMP SPEC 112-32-1.
- △ FINISH - NICKEL PLATE, 100 MIN μINCHES THICK, PER AMP SPEC 112-246-1.
- △ HARDWARE FURNISHED FOR:
 - 192447-7 2 NUTS, 2 WASHERS
 - 1-192447-1 2 NUTS, NO WASHERS
 - 1-192447-9 1 NUT, NO WASHERS
- △ UNLESS OTHERWISE SPECIFIED, φ"F" EQUALS φ"C".
- △ OBSOLETE PARTS: OBSOLETE CIS STREAMLINING PER D.RENAUD/D.SINISI

△ OBSOLETE	-	-	9.4[.37]	φ6.1[.24]	1/2-20UNF-2A	31.7[1.25]	NO	A	1	-	2-192447-0	
	-	-	17.0[.67]	φ8.2[.32]	9/16-18UNF-2A	34.2[1.35]	YES	A	1	-	1-192477-9	
	-	-	17.0[.67]	φ8.2[.32]	9/16-18UNF-2A	34.2[1.35]	NO	A	1	09112	1-192447-8	
	-	-	9.4[.37]	φ4.1[.16]	5/16-32UNEF-2A	19.6[.77]	NO	A	1	-	1-192447-7	
	41.8[1.64]	19.9[.78]	φ35.0[1.38]	M50 X 1.5-6g	62.0[2.44]	NO	B	1	09133	1-192447-6		
△ OBSOLETE	-	43.1[1.69]	20.7[.81]	φ30.0[1.18]	M48 X 1.5-6g	62.0[2.44]	NO	B	1	09079	1-192447-5	
	-	-	21.9[.86]	φ25.0[.98]	1 5/8-16UN-2A	62.2[2.45]	NO	B	1	09165	1-192447-4	
	-	-	21.1[.83]	φ20.1[.79]	1 1/4-18UNEF-2A	42.2[1.66]	NO	A	1	09173	1-192447-3	
	-	-	17.3[.68]	φ12.0[.47]	3/4-16UNF-2A	34.0[1.34]	NO	A	1	10260	1-192447-2	
△ OBSOLETE	-	-	17.0[.67]	φ8.2[.32]	9/16-18UNF-2A	34.2[1.35]	YES	A	1	-	1-192447-1	
	-	-	8.4[.33]	φ2.3[.09]	5/16-32UNEF-2A	16.5[.65]	NO	A	1	09183	1-192447-0	
	-	-	9.4[.37]	φ4.1[.16]	M8 X 0.75-6g	19.6[.77]	NO	A	1	09026	192447-9	
	-	-	9.4[.37]	φ4.1[.16]	5/16-32UNEF-2A	19.6[.77]	NO	A	1	09111	192447-8	
	-	-	9.4[.37]	φ4.1[.16]	5/16-32UNEF-2A	19.6[.77]	YES	A	2	10244	192447-7	
	-	-	14.5[.57]	φ4.1[.16]	5/16-32UNEF-2A	28.4[1.12]	NO	A	1	10394	192447-6	
	φ4.3[.17]	-	14.5[.57]	φ4.1[.16]	5/16-32UNEF-2A	38.1[1.50]	NO	A	1	10611	192447-5	
	-	-	9.4[.37]	φ6.1[.24]	1/2-28UNEF-2A	19.6[.77]	NO	A	1	10934	192447-4	
	-	-	9.4[.37]	φ6.1[.24]	1/2-20UNF-2A	19.6[.77]	NO	A	2	10263	192447-3	
	-	-	9.4[.37]	φ6.1[.24]	1/2-20UNF-2A	19.6[.77]	NO	A	1	09182	192447-2	
△ OBSOLETE	-	-	19.2[.76]	φ16.1[.63]	15/16-20UNEF-2A	38.1[1.50]	NO	A	1	09066	192447-1	
	F	E	D	C	B	A		H'WARE INCL	FIGURE	FINISH (NOTE #)	WAS	PART NO.

DO NOT SCALE PRINT. UNLESS SPECIFIED DIMENSIONS IN mm [INCHES] TOLERANCES ON : 1 PLC DEC ± 0.5 [.02] 2 PLC DEC ± 0.25 [.010] ANGLES ± -	DR D. WILSON 04-02-92 CHK R. JAYNE 5-04-92 APPD A. GRIFFIN 5-04-92	 AMP Incorporated Harrisburg, PA 17105-3608
MATERIAL BRASS	APPD P. GLASER 5-06-92 PRODUCT SPEC	
FINISH △△	APPLICATION SPEC -	NAME THREADED SLEEVE SOCKET ASSY
WEIGHT -	SIZE C	CAGE CODE 00779
	SCALE NONE	DRAWING NO 192447
		SHEET 1 OF 2

AMP 1471-6 REV 7-90 Translated from 01031.040412 (YMMCD) (HARRIS) from ComputerVision, Inc., Medusa Revision 12.2.97

CUSTOMER DRAWING

THIS DRAWING IS UNPUBLISHED. RELEASED FOR PUBLICATION
 © COPYRIGHT 19 BY AMP INCORPORATED. ALL INTERNATIONAL RIGHTS RESERVED.

REVISIONS								
LOC	DIST	P	F	ZONE	LTR	DESCRIPTION	DATE	APPD
CH	11					- SEE SHEET 1	05-12-92	

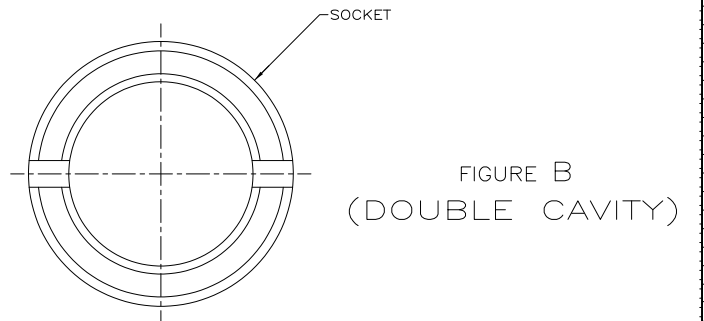
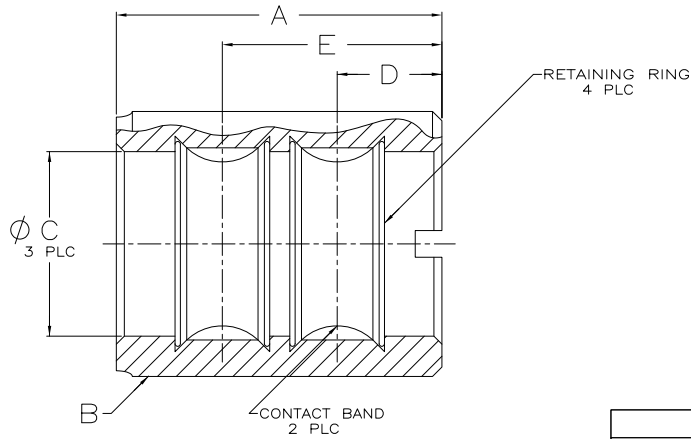
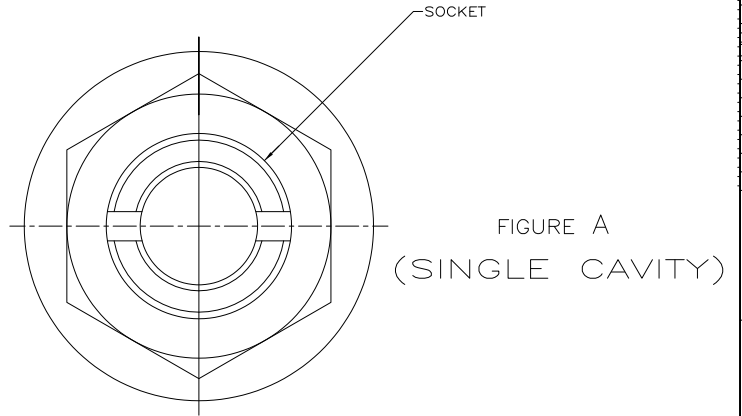
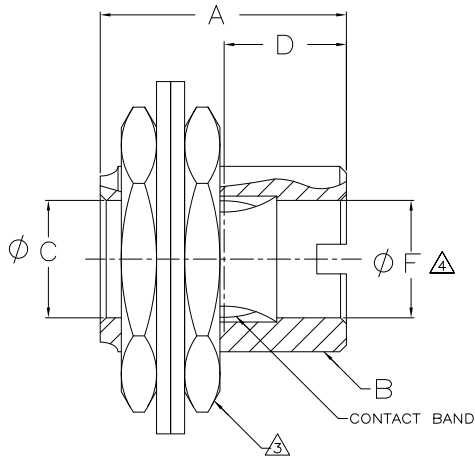

DO NOT SCALE PRINT. UNLESS SPECIFIED DIMENSIONS IN mm [INCHES] TOLERANCES ON : 1 PLC DEC ± 0.5 [.02] 2 PLC DEC ± 0.25 [.010] ANGLES ± -		DR D. WILSON 04-02-92		AMP Incorporated Harrisburg, PA 17105-3608	
MATERIAL		CHK R. JAYNE 5-04-92			
FINISH		APPD A. GRIFFIN 5-04-92		NAME	
WEIGHT		APPD P. GLASER 5-06-92		PRODUCT SPEC	
APPLICATION SPEC		SIZE	CAGE CODE	DRAWING NO	
-		③	00779	192447	
-		SCALE	NONE	SHEET	2 OF 2

AMP 1471-6 REV 7-90
 05-MAR-96 07:08:36 amp26068 /home/amp26068/hugin

CUSTOMER DRAWING