

4

3

2

1

THIS DRAWING IS UNPUBLISHED. RELEASED FOR PUBLICATION
 © COPYRIGHT - BY - ALL RIGHTS RESERVED.

LOC		DIST		REVISIONS			
P	LTR	DESCRIPTION	DATE	DWN	APVD		
SEE SHEET 1.							

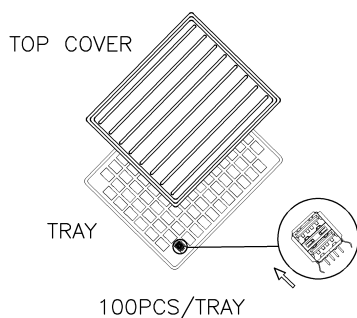

NOTES:

- MATERIAL:**
TRAY: PS or PET
- DIMENSION:**
TRAY: L=270, W=230, H=21
SHIPPING CARTON: L=470, W=280, H=210
- QUANTITY:**
PRIMARY PACKING: 100 PCS/TRAY
SECONDARY PACKING: 20 TRAY/CARTON(2,000PCS)
- WEIGHT:**

BACK COVER	W/	W/O
NET WEIGHT	10.68 Kg	9.4 Kg
GROSS WEIGHT	12.18 Kg	10.9 Kg

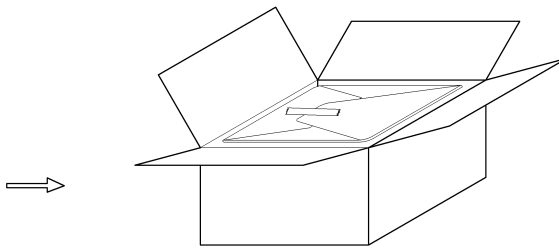
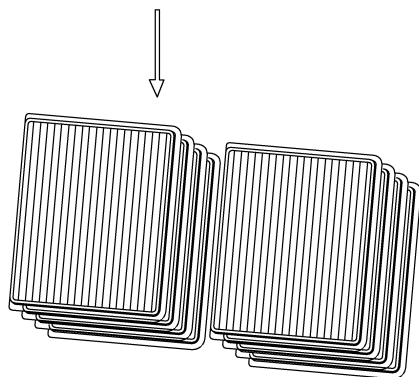

20TRAY/CARTON

THIS DRAWING IS A CONTROLLED DOCUMENT.		DWN		
DIMENSIONS: MM		CHK	NAME	
		APVD	STACKED USB CONNECTOR R/A, DIP, A TYPE	
TOLERANCES UNLESS OTHERWISE SPECIFIED: 0 PLC ± - 1 PLC ± - 2 PLC ± - 3 PLC ± - 4 PLC ± - ANGLES ± -		PRODUCT SPEC	SIZE	CAGE CODE
MATERIAL		QUALIFICATION TEST REPORT	A3	00779
FINISH		WEIGHT	DRAWING NO. 1734022	
		CUSTOMER DRAWING	RESTRICTED TO	
		SCALE	SHEET	REV
			2 of 2	E