SUPER SEAL コネクタ
SUPER SEAL CONNECTOR

注記) 21 ページ以降日本語版

THIS SPECIFICATION IS STRUCTURED AS FOLLOWS:

<u>ITEM</u>	<u>PAGE</u>
1.....SCOPE	2/41
2.....APPLIED STANDARD	2/41
3.....PRODUCT TYPES	2/41
4. MATERIAL.....	3/41
5..... DIMENSION AND CONFIGURATION.....	3/41
6..... RATING	3/41
7..... MEASURING METHOD AND PERFORMANCE.	4/41~10/41
8..... TEST STRUCTURE AND SEQUENCE.....	11/41~13/41
9..... TEST METHOD	14/41~19/41
10..... TEST CONDITION.....	19/41
11..... PACKAGING AND MARKING	19/41

1. SCOPE

This specification applies to the SUPER SEAL Connector.

2. APPLIED STANDARD

The following standards are applied as a part of this specification sheet.

(1) JIS (Japanese Industrial Standards)

- JIS D0203: Wet-Proof & Water-Proof Test Method Automobile Parts
- JIS Z8901: Dusts and Aerosols for Industrial Testing

(2) MIL (Military Specifications and Standards)

- MIL 202: Test Method for Electronic and Electrical Parts

(3) Qualification Test Report: 501-78143
3. PRODUCT TYPES

	Structure	No. of Pos.		Part Number	Old Part No.		
Cap Housing Connector	Cap Housing assy	60 (34+26) Horizontal Type		1437288-3	3900134-6011		
				6437288-3	—		
				1437288-5	3900135-6011		
				6437288-5	—		
				3-1437285-2	3900136-6011		
				3-6437285-2	—		
				1473427-1	—		
				6473427-1	—		
		34		Horizontal Type		1437288-1	3900134-3411
						6437288-1	—
						1437288-2	3900134-3412
						6437288-2	—
						2-1437285-5	3900135-3411
						2-6437285-5	—
						2-1437285-6	3900135-3412
						2-6437285-6	—
						3-1437285-0	3900136-3411
						3-6437285-0	—
				Vertical Type		3-1437285-1	3900136-3412
						3-6437285-1	—
						1747359-1	—
						1747359-2	—
						2-1447232-3	3900279-3411
						2-6447232-3	—
						2-1447232-4	3900279-3412
						2-6447232-4	—

	Structure	No. of Pos.		Part Number	Old Part No.			
Cap Housing Connector	Cap Housing Assy	26	Horizontal Type	9-1437287-8	3900134-2611			
				9-6437287-8	—			
				9-1437287-9	3900134-2612			
				9-6437287-9	—			
				5-144223-0	3900135-2611			
				5-644223-0	—			
				1437288-4	3900135-2612			
				6437288-4	—			
				2-1437285-8	3900136-2611			
				2-6437285-8	—			
				2-1437285-9	3900136-2612			
				2-6437285-9	—			
				1473423-1	—			
				6473423-1	—			
			1473423-2	—				
			6473423-2	—				
						Vertical Type	1437288-6	3900168-26
							1473418-1	—
				6473418-1	—			
				1473418-2	—			
				6473418-2	—			
Plug Housing Connector	Receptacle contact assy	—	—	3-1447221-3	3900187-01			
		—	—	3-1447221-4	3900187-02			
	Plug Housing assy	34	—	—	4-1437290-0	3900113-3421		
			—	—	4-1437290-1	3900113-3422		
			—	—	2-1437285-3	3900113-3411		
			—	—	3-1437290-9	3900113-3412		
			—	—	3-1437290-7	3900113-2621		
			—	—	3-1437290-8	3900113-2622		
		26	—	—	2-1437285-2	3900113-2611		
			—	—	1-1447232-7	3900113-2612		
			—	—	1473416-1	—		
			—	—	1473416-2	—		
Hole Plug	—	—	4-1437284-3	3400130				

4. MATERIAL

Per the drawings.

5. DIMENSION AND CONFIGURATION

Per the drawings.

6. RATING

Item	Rating & Condition
Current	Refer to the table below
Voltage	250V (AC, DC)
Temperature	-40~+125°C
Wire	Conductor 0.5~1.25mm ² Insulation Cover ϕ 1.6~ ϕ 2.2

Connector Allowable Current

(Allowable maximum temperature in the vicinity of the contacting point is 150°C)

(A)

Measurement Set-up		Ambient Temperature (°C)			
		60	80	100	125
(Wire Size 0.85mm ² min.)	All positions active	7	6	5	3
	Only single position active	15	13	11	6

7. MEASUREMENT METHOD AND PERFORMANCE

No.	ITEM	MEASUREMENT METHOD	PERFORMANCE
7.1	External Appearance	Visual and touch feeling inspection.	There shall be no detrimental crack, rust, play, scratch, deformation and etc.
7.2	Feeling on Mating /Unmating	Feeling is verified by mating and unmating the contact, housing and connector	There should be no detrimental binding.
7.3	Insertion Force	Pin contact or cap housing connector is fastened first, then receptacle contact or plug housing and plug connector are mated at a constant mating speed of approx. 100mm/min. or less toward the axis.	Contact 4.9N(0.5kgf) or less Housing 58.8N(6kgf) or less Connector 98N(10kgf) or less
7.4	Withdrawal Force	Pin contact or cap housing connector is fastened first, then mated receptacle contact or plug housing and the connector is pulled at a constant speed of approx. 100mm/min. or less toward the axis. (Plug housing should be installed without locking.)	Contact 4.9N(0.5kgf) or less Housing 58.8N(6kgf) or less Connector 98N(10kgf) or less

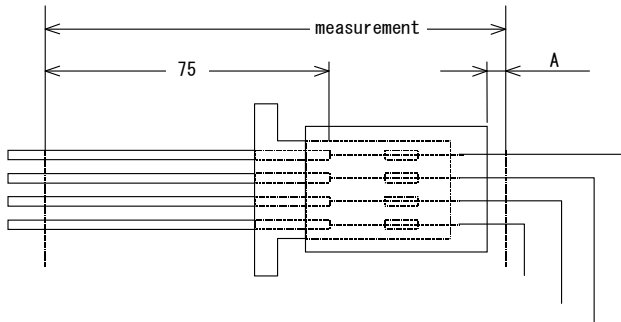
No.	ITEM	MEASUREMENT METHOD	PERFORMANCE								
7.5	Voltage Drop	<p>As shown in Fig.1 while feeding open voltage of $20 \pm 5\text{mV}$ and short circuit current of $10 \pm 0.5\text{mA}$ to the mated connector, measurement is taken at the point 75mm apart from the crimped barrel when temperature of the mated contact has saturated and then voltage drop by the wire is subtracted. (Resistance of wire is per Table 1.)</p> <p>Fig.1</p>  <p>Table 1</p> <table border="1" data-bbox="513 1270 867 1465"> <thead> <tr> <th>Wire size</th> <th>Resistance ($\text{m}\Omega / 75\text{mm}$)</th> </tr> </thead> <tbody> <tr> <td>0.5</td> <td>2.45</td> </tr> <tr> <td>0.85</td> <td>1.56</td> </tr> <tr> <td>1.25</td> <td>1.07</td> </tr> </tbody> </table>	Wire size	Resistance ($\text{m}\Omega / 75\text{mm}$)	0.5	2.45	0.85	1.56	1.25	1.07	<p>Initial: $5\text{m}\Omega$ or less After Durability Test: $10\text{m}\Omega$ or less</p>
Wire size	Resistance ($\text{m}\Omega / 75\text{mm}$)										
0.5	2.45										
0.85	1.56										
1.25	1.07										

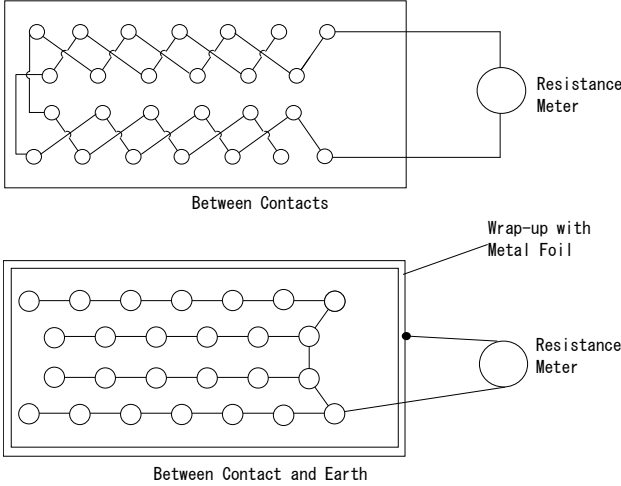
No.	ITEM	MEASUREMENT METHOD	PERFORMANCE
7.6	Insulation Resistance	<p>As shown in Fig.2 the connector is mated and insulation resistances between neighboring contacts and between contact and earth are measured with insulation resistance meter of DC 500V.</p> <p style="text-align: center;">Fig. 2</p> 	100M Ω or more
7.7	Dielectric Withstanding Voltage	<p>As shown in Fig.2 while the connector is mated, 1000VAC or 1600V DC voltage of commercial power frequency is applied of duration of 1 minute between contacts and between contact and earth.</p>	Insulation breakdown does not develop.

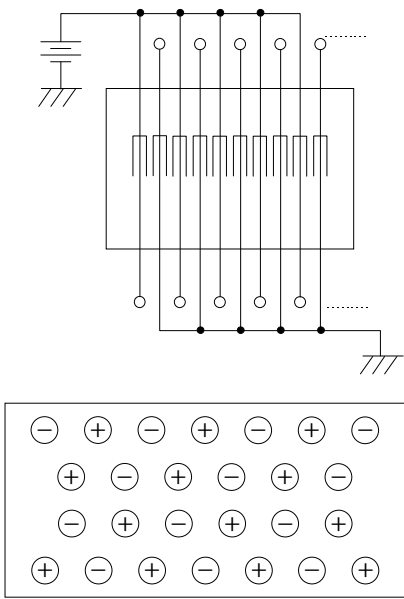
No.	ITEM	MEASUREMENT METHOD	PERFORMANCE
7.8	Leak current	<p>Peak value of leak current and integrated quantity are measured while DC 28 volt is applied with the circuit shown in Fig.3.</p> <p>The wire used for testing should be minimum size.</p> <p>Fig. 3</p> 	Peak Value: 100 μ A or less

No.	ITEM	MEASUREMENT METHOD		PERFORMANCE
7.9	Contact Solderability	Solder bath : Sn-40Pb Solder Temperature : 235±5°C Immersion Duration : 5±0.5sec. Flux : Alpha100 AMP Spec. 109-5203	Matte Tin plating only Solder bath : Sn-3Ag-0.5Cu Solder Temperature : 250±5°C Immersion Duration : 5±0.5sec. Flux : ULF-300R	Wet Solder Coverage : (Plated area only) 95% Min.
7.10	Contact Insertion Characteristic (Between Contact and Housing)	Contact crimped on free-length of wire is inserted into the proper location of the plug housing. Holding position of the wire is 20mm apart from the crimp barrel. Insertion speed is 100mm/min. or less.		Contact can be inserted without bending of wire.
7.11	Contact Withdrawal Characteristic (Between Contact and Housing)	Withdraw the contact inserted under the condition of 6.10.		There shall be no detrimental binding, crack and deformation.
7.12	Contact Retention Force (Between Contact and Housing)	About 100mm long wire is crimped with the plug housing connector and the receptacle contact is fastened and then the load that causes separation of contact from the housing with the wire pulled toward the axis at a constant speed of approx. 100mm/min. is measured.		58.8N(6kgf) or more
7.13	Strength of Crimp Connection (Between Contact and Wire)	After the receptacle contact with wire crimped is fastened and then the load that causes wire breakage or separation of the wire from the crimped barrel with the wire pulled toward the axis at a constant speed of approx. 100mm/min. is measured.		Wire size 0.5 88.2N (9kgf) or more 0.85 127.4N(13kgf) or more 1.25 176.4N(18kgf) or more
7.14	Housing Retention Force (Housing Locking Strength)	After the cap housing is fastened, mated plug housing is pulled at a constant speed of approx. 100mm/min.		The lock mechanism shall not get released or broken less than 98N(10kgf).

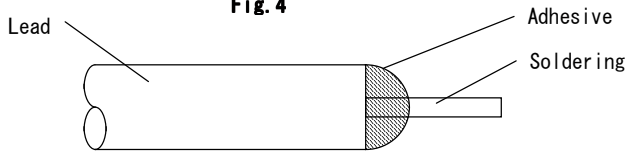
No.	ITEM	MEASUREMENT METHOD	PERFORMANCE
7.15	Seal Ability	<p>Seal Ability is measured with compressed air fed into the water-proof section of the connector. Before running the test, the tip of the wire is soldered and then sealed with adhesives. (Fig. 4) Measurement is taken with 9800Pa (gage) (0.1kg/cm²) compressed air fed into the connector submerged for duration of 30 seconds. If the air does not leak for 30 seconds, the pressure is raised each time by an increment of 9800Pa (gage) (0.1kg/cm²).</p> <p style="text-align: center;">Fig. 4</p>  <p>The diagram, labeled Fig. 4, shows a cross-section of a cylindrical connector. On the left side, there are two circular openings representing the lead wires, with a label 'Lead' pointing to them. On the right side, a wire is inserted into the connector. This wire is secured by a 'Soldering' joint, which is a shaded, semi-circular area. Surrounding the soldering joint is a layer of 'Adhesive', also indicated by a label. The main body of the connector is shown as a simple cylinder.</p>	<p>Initial: 98kPa (gage) (1kg/cm²) or more</p> <p>After Durability Test: 48kPa (gage) (0.5kg/cm²) or more</p>

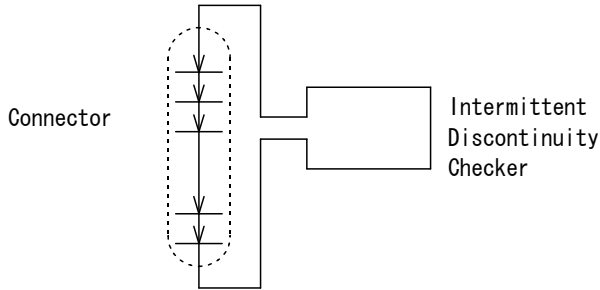
No.	ITEM	MEASUREMENT METHOD	PERFORMANCE
7.16	Temperature Rise Magnitude	"Temperature Rise Test" of item No. 8.16 is made and temperature of connector surface near the mated interface of the contact, is measured when the temperature has saturated.	Temperature rise: 60°C or less.
7.17	Intermittent Discontinuity	<p>Power of 12V or less open voltage and 1A or less short circuit current is applied to the mated connector with the contacts in all positions connected in series and then intermittent discontinuity is monitored with an intermittent discontinuity detector. (Fig.5)</p> <p>Fig. 5</p>  <p>Connector</p> <p>Intermittent Discontinuity Checker</p>	Intermittent discontinuity shall not last for 10 μ sec or more.

8. TEST STRUCTURE AND SEQUENCE

8.1 Characteristic Test

The test is made basically in line with the sequence shown in the Table 3.

Table 3

Test Sample Sequence	Contact	Housing	Connector
1	External Appearance	External Appearance	External Appearance
2	Insertion Force	Insertion Force	Contact Insertion Characteristic
3	Withdrawal Force	Withdrawal Force	Insertion Force
4	Feeling of mating/unmating	Feeling of mating/unmating	Withdrawal Force
5	Contact Force	Housing Retention Force	Feeling of mating/unmating
6	_____	_____	Contact Withdrawal Characteristic
7	_____	_____	Contact Retention Force
8	_____	_____	Contact Solderability

8.2 Durability Test

The test is made basically according to the Table 4.

Table 4

Sequence Group Designation	BEFORE TEST	TEST I	TEST II	TEST III
A	————— Low level voltage and current resistance	“Kojiri” durability Low level voltage and current resistance External Appearance	Vibration Intermittent discontinuity※ External Appearance※ Low level voltage and current resistance	Current cycle Low level voltage and current resistance External Appearance
	————— Low level voltage and current resistance	“Kojiri” durability Low level voltage and current resistance External Appearance	Temperature rise Temperature rise※ Low level voltage and current resistance	
C	————— Insertion force Low level voltage and current resistance Seal ability Withdrawal force	High temperature exposure Low level voltage and current resistance Seal ability Withdrawal force Insertion force	Low temperature exposure Low level voltage and current resistance Current resistance Seal ability Withdrawal force Insertion force	
	————— Insertion force Low level voltage and current resistance Seal ability Withdrawal force	Thermal shock Low level voltage and current resistance Seal ability Withdrawal force Insertion force	Water-Proof Leak current※ Low level voltage and current resistance Seal ability Withdrawal force Insertion force	
E	————— External appearance	Over-current External appearance		
F	————— Insertion force Low level voltage and current resistance Insulation resistance Withdrawal force	“Kojiri” durability Low level voltage and current resistance External appearance	Dust-proof Low level voltage and current resistance	Oil-proof, Solvent-proof Low level voltage and current resistance Insulation resistance Withdrawal force Insertion force External appearance
	————— Low level voltage and current resistance Insulation resistance Seal ability	Freezing Leak current	Corrosion gas Low level voltage and current resistance Seal ability	Ozone deterioration Low level voltage and current resistance Insulation resistance Seal ability External appearance
H	————— Low level voltage and current resistance	Salt Spray Leak current※ Low level voltage and current resistance		

Sequence Group Designation	BEFORE TEST	TEST I	TEST II	TEST III
I	insertion force	Weather-proof		
	Low level voltage and current resistance	Low level voltage and current resistance		
J	Insulation resistance	Insulation resistance		
	Withstanding voltage	Withstanding voltage		
	Withdrawal force	Withdrawal force		
	Insertion force	Insertion force		
J	External appearance	High pressure cleaning		
		Leak current		
		External appearance		

Note※: This measurement item is continually measured thru the test.

- Remark :
1. The test subject and item to be measure are shown above and below the dotted line respectively in the Table 4.
 2. The measurement items shall be measured one after another sequentially in each item.

9. TEST METHOD

9.1 “Kojiri”*(Rocking motion) Durability Test

After the cap housing connector is fastened, the plug housing is mated in the regular manner and then 78.4N (8kgf) force is applied to-and-fro twice as shown in Fig.6. This test is repeated with the connector half if pulled from other half with slide distance stepped up by an increment of 1mm each time until the connector is fully unmated. These test procedure is defined as one cycle and is repeated 25 cycles. Test with the force applied towards right and left, is also made in the same manner. (Test with the force applied towards combined direction of to/fro and right/left is also acceptable.)

Fig. 6

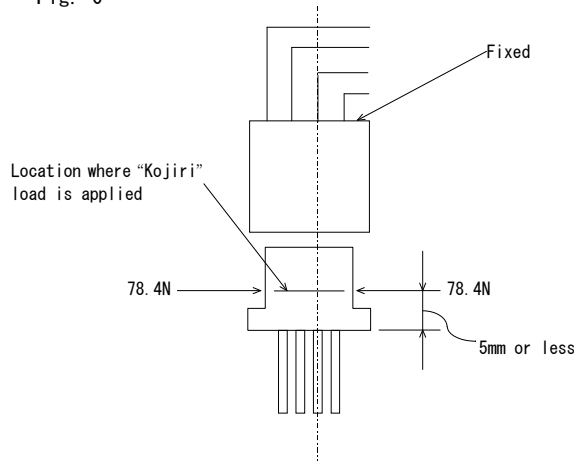

9.2 High Temperature Exposure Test

The connector is kept in a thermostatic chamber for 1000 hours and then taken out to be exposed to the normal temperature until it cools off to the temperature. The chamber temperature is set at 125°C.

9.3 Low Temperature Exposure Test

The same test procedure as above is made except that the exposure time is 150 hours and the chamber temperature is set at -40°C.

9.4 Thermal Shock Test

The connector is placed in a thermostatic chamber and given with 200cycles of heating/cooling process in the heating/cooling pattern shown below and then is taken out of the chamber to be left in the normal temperature for more than 2hours.

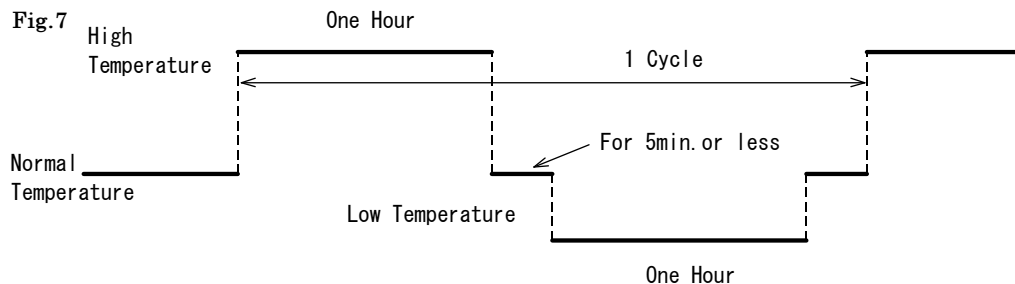

Thermostatic chamber temperature is set at 125°C as the high temperature and -40°C as the low temperature

9.5 Salt Spray Test

The connector is hung in a sealed tank and sprayed with mist of salt water for 96hours and then hung in a humidity chamber to be left in there for 96hours.

The salt water ($35\pm 5^{\circ}\text{C}$ temperature, $5\pm 1\%$ salt density, $1.0268\sim 1.0413$ specific gravity, PH $6.5\sim 7.2$) is sprayed at pressure of $68.6\sim 176.5\text{KPa}$ (gage) ($0.7\sim 1.8\text{kg}/\text{c m}^2$). The humidity chamber is set at temperature of $80\pm 5^{\circ}\text{C}$ and relative humidity of $90\sim 95\%$. Measurement is taken after the connector has dried up in normal temperature. During the salt water spray, 28 volt is applied across each contact of the connector to monitor leak current as shown in Fig. 3.

9.6 Oil-Proof, Solvent-Proof Test

The connector is dipped in various oil. Oil temperature is set at $50\pm 2^{\circ}\text{C}$. Test is made in the sequence shown below.

Torq. Con. Oil (Castle Auto Fluid Special)	Dipping for 1hour	Dipping in kerosene for 5min.
Transmission Oil (SAE 90)	Dipping for 1hour	Dipping in kerosene for 5min.
Engine Oil (SAE 10W-30)	Dipping for 1hour	Dipping in kerosene for 5min.
Clutch oil (Toyota Standard SHD)	Dipping for 1hour	Dipping in kerosene for 5min.
Brake Oil (Toyota Standard SHF)	Dipping for 1hour	Dipping in kerosene for 5min.

Another dipping test is also made on other sample in the following sequence with oil temperature set at $50\pm 2^{\circ}\text{C}$.

- Washer liquid (available in the market) Dipping for 1hour
- Rinsing and dipping with or in tap water for 5min.
- Antifreezing solution (Castle Long Life Coolant) Dipping for 1hour
- Rinsing and dipping with/or in tap water 5min.

Drying while left in room temperature

9.7 Water-Proof Test

The connector is placed in the thermostatic chamber, heated up 40min. and then immediately sprayed with water of normal temp. for 20min. in an water-proof test chamber. This is defined as 1cycle. The cycle is repeated 48 times for the test. The spray is made according to S2 of JIS D0203. Potential of 28 volt is applied across each contact of the connector during the water spray by the circuit shown in the Fig.3 and leak current is monitored. At running the test, the leading end of the lead wire shall be pulled out from the test chamber after having been soldered and then sealed with adhesives. The thermostatic chamber is set at 125°C.

9.8 Freezing Test

The connector is put in a thermostatic chamber set at $-30\pm 5^{\circ}\text{C}$ immediately after dipped in boiling water for 1hour and then taken out of the chamber after the water stuck on the connector has frozen. Potential of 28 volts is applied across each contact of the connector during the test with the circuit shown in Fig.3, and leak current is monitored.

9.9 Corrosion Gas Test

The connector is left in the test chamber for 24hours. The chamber is fed with 10ppmSO₂ gas with 90% or more humidity and set at normal temperature.

9.10 Ozone Deterioration Test

The connector is left in the test chamber for 24hours. The chamber is fed with $50\pm 5\text{ppm}$ ozone gas and set at 40°C.

9.11 Vibration Test at High Temperature

The connector is fastened to vibration stand and vibrated on each of the 3 mutually perpendicular axis (X, Y, Z) in 125°C atmosphere. Other condition of the vibration is set by the Table 5. During the test, electrical current is turned on as shown in Fig. 8 and intermittent discontinuity is monitored.

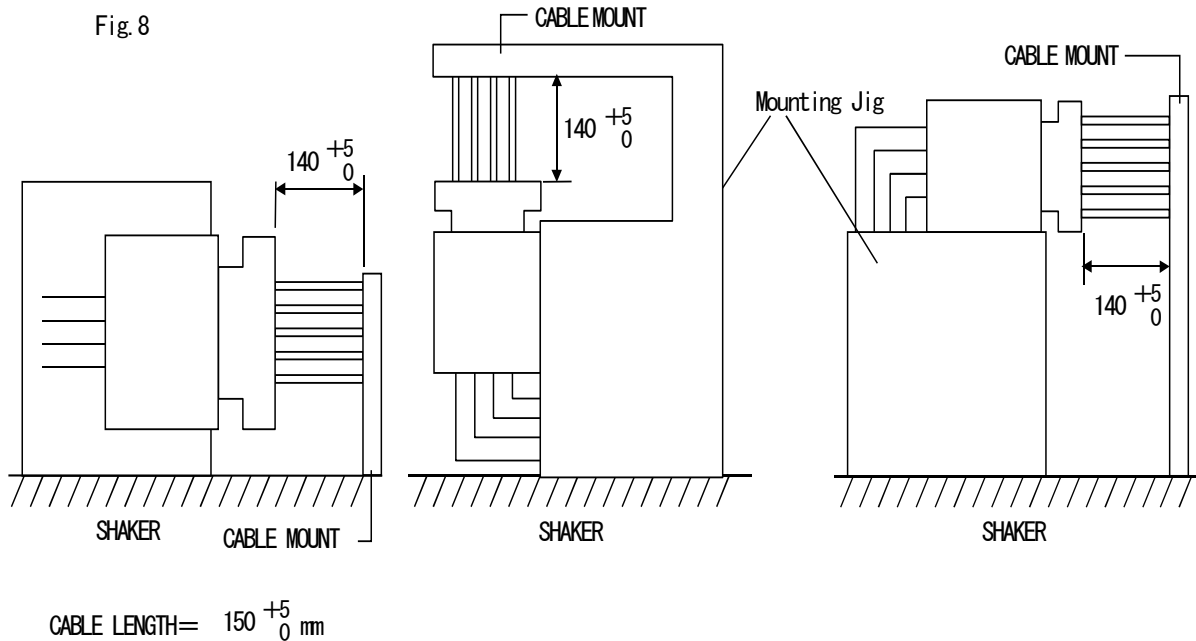
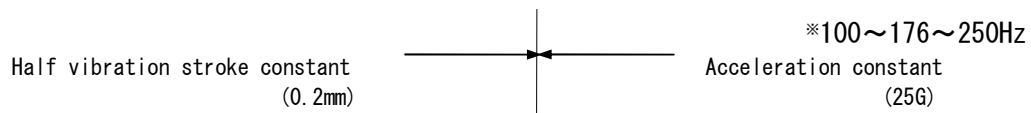

Table 5

Acceleration (m/s ²)	Vibration Duration (h)	Vibration Frequency (Hz)
98~245 (10~25G)	3 hours per direction, Total of 9 hours	50~100 ... 98m/s ² (10G) constant 100~250* ... Half vibration stroke of 0.2mm constant ~245m/s ² (25G) constant Sweep Time 3min. (Log Sweep)



9.12 Weather-Proof Test

The connector is left in sunny outdoors for 12 months.

9.13 Current Cycle Test

① Contacts of signal positions of the connector are turned on with the current of 3 Ampere, and power positions with the current of 4 Ampere. Turning on current for 45 min. and then turning off for 15 min. are defined here as one cycle of test. The connector is tested with 200 cycles.

② Contacts of signal positions of the connector are turned on with the current of 3 Ampere and power positions with the current of 8 Ampere shown in fig. 9 at 120°C atmosphere. This test cycle is repeated 50 times with vibration applied in draft free chamber according to the condition specified in the Table 5. The connector is vibrated perpendicular to the terminal axis.

Fig. 9

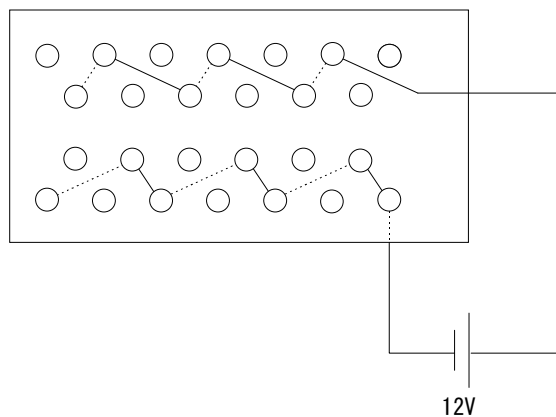

9.14 Over-current Test

While the connector is held horizontally in a draft free chamber, current is turned on thru one circuit arbitrarily chosen. Current magnitude and time length for the over-current test are selected per the Table 6.

Table 6

Wire Size	Test ①		Test ②	
	Current Value (A)	Conduction Time (min.)	Current Value (A)	Conduction Time (s)
0.5	30	5	80	5
0.85	40		110	
1.25	50		170	

9.15 Dust-Proof Test

Hang the mated connector in the chamber of 900~1200mm each sides. Jet 10 seconds the 1.5Kg of powder specified by JIS Z8901-6 in every 15 minutes. This test cycle is repeated 8 cycles. Unmated and mate the connector in every 2 cycles.

9.16 Temperature Rise Test

Conduct the current of 15 Ampere on an optional contact of the connector, then conduct the current of 6 Ampere on all of the contact. Measurement is based on per temperature rise magnitude 6.16.

9.17 High-Pressure Cleaning Test

Water-Jet Pressure: 80Kgf/cm²

Water Quantity: 600ℓ/hr

Distance between Water-Nozzle and connector: 300mm

Water-Jet Direction: Fig. 10

Test Cycle: Keep connector at 100°C atmosphere



Water-jet cleaning 30 sec.



Natural cooling 1 minute



Repeat 10 cycles

Fig. 10

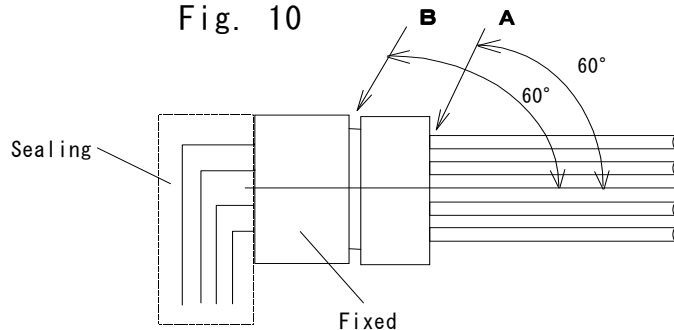

10. TEST CONDITION

- (1) Contact and housing to be tested are to be selected randomly.
- (2) Contact and housing to be tested are to be crimped with wire of the maximum size except when otherwise noted. Wire length shall be decided each time.
- (3) Wire used in the tests should have enough performance of Heatstability and Solvent-resistance.
- (4) Test is to be made in the normal temperature and humidity except when otherwise noted.
- (5) Test is to be made with the connector mated except when otherwise noted.
- (6) Tolerance of the test conditions is $\pm 10\%$ except when otherwise noted.
- (7) Quantity of test sample will be adjusted depending on situation.
- (8) Measurement for each test is to be made on 2 positions or more.

11. PACKAGING AND MARKING

Packaging units will each contain suitable quantities of the product. Arrangements for transport and storage shall be such that no loss or damage is suffered. The following labeling will be displayed.

- Product description or Cat. No.
- Quantity contained
- Manufacturer's name or abbreviated name
- Date of manufacture or Lot. No.

本仕様書は、以下の内容により構成される。

<u>項 目</u>	<u>ページ</u>
1. 適 用 範 囲	22/41
2. 適 用 規 格	22/41
3. 種 類	22/41
4. 材 質	24/41
5. 寸 法 及 び 形 状	24/41
6. 定 格 及 び 適 用 条 件	24/41
7. 測 定 方 法 及 び 性 能	25/41～31/41
8. 試 験 構 成 及 び 順 序	32/41～34/41
9. 試 験 方 法	35/41～41/41
10. 試 験 条 件	41/41
11. 梱 包 及 び 表 示	41/41

1. 適用範囲

本仕様書は、SUPER SEALコネクタについて規定する。

2. 適用規格

以下の規格を本仕様書の一部として適用する。

- (1) JIS (Japanese Industrial Standards: 日本工業規格)
 - ・ JIS D0203: 自動車部品の耐水試験方法
 - ・ JIS Z8901: 試験用ダスト
- (2) MIL (Military Specifications and Standards)
 - ・ MIL 202: Test Method for Electronic and Electronical Parts
- (3) 認定試験報告書: 501-78143

3. 種類

	構成	極数	型番	旧型番		
キャップハウジング コネクタ	キャップハウジング アッセムブリ	60 (34+26) 水平タイプ	1437288-3	3900134-6011		
			6437288-3	—		
			1437288-5	3900135-6011		
			6437288-5	—		
			3-1437285-2	3900136-6011		
			3-6437285-2	—		
			1473427-1	—		
			6473427-1	—		
		34	水平タイプ	1437288-1	3900134-3411	
				6437288-1	—	
				1437288-2	3900134-3412	
				6437288-2	—	
				2-1437285-5	3900135-3411	
				2-6437285-5	—	
				2-1437285-6	3900135-3412	
				2-6437285-6	—	
				3-1437285-0	3900136-3411	
				3-6437285-0	—	
				3-1437285-1	3900136-3412	
				3-6437285-1	—	
				1747359-1	—	
				1747359-2	—	
				垂直タイプ	2-1447232-3	3900279-3411
					2-6447232-3	—
					2-1447232-4	3900279-3412
					2-6447232-4	—

	構成	極数	型番	旧型番	
キャップハウジング コネクタ	キャップハウジング アッセンブリ	26	水平タイプ	9-1437287-8	3900134-2611
				9-6437287-8	—
				9-1437287-9	3900134-2612
				9-6437287-9	—
				5-1447223-0	3900135-2611
				5-6447223-0	—
				1437288-4	3900135-2612
				6437288-4	—
				2-1437285-8	3900136-2611
				2-6437285-8	—
				2-1437285-9	3900136-2612
				2-6437285-9	—
				1473423-1	—
				6473423-1	—
				1473423-2	—
				6473423-2	—
				プラグハウジング コネクタ	リセプタクル コンタクト アッセンブリ
—	3-1447221-4	3900187-02			
プラグハウジング アッセンブリ	34	4-1437290-0	3900113-3421		
		4-1437290-1	3900113-3422		
		2-1437285-3	3900113-3411		
		3-1437290-9	3900113-3412		
		3-1437290-7	3900113-2621		
26	3-1437290-8	3900113-2622			
	2-1437285-2	3900113-2611			
	1-1447232-7	3900113-2612			
	1473416-1	—			
1473416-2	—				
付属部品	埋 栓	—	4-1437284-3	3400130	

4. 材質

図面による。

5. 寸法及び形状

図面による

6. 定格及び適用条件

項目	定格値及び条件
電流	下表参照
電圧	250V (AC、DC)
温度	-40~+125°C
電線	芯線部 0.5~1.25mm ² 被覆径 φ1.6~φ2.2

コネクタ許容電流: コンタクト許容温度 150°C

(A)

設定条件		周囲温度(°C)			
		60以下	80以下	100以下	125以下
電線サイズ 0.85以上	全極通電	7	6	5	3
	単極通電	15	13	11	6

7. 測定方法及び性能

番号	項目	測定方法	性能
7.1	外観	目視及び触感により行う。	有害な亀裂、錆、がた、傷、変形などがないこと。 着火のないこと（過電流通電）。
7.2	挿入離脱の フィーリング	コンタクト、ハウジング及びコネクタの挿入離脱を行い、そのフィーリングを確認する。	有害な引っ掛かりなどがないこと。
7.3	挿入力	ピンコンタクトまたはキャップハウジングコネクタを固定し、リセプタクルコンタクトまたはプラグハウジング及び同コネクタを軸方向へ約100mm/min.以下の一定の速さで嵌合させる。	コンタクト ハウジング コネクタ 4. 9N(0.5kgf) 以下 58. 8N(6kgf) 以下 98N(10kgf) 以下
7.4	離脱力	ピンコンタクトまたはキャップハウジングコネクタを固定し、嵌合したリセプタクルコンタクトまたはプラグハウジング及び同コネクタを軸方向へ100mm/min.以下の一定の速さで引っ張る。 (プラグハウジングは、ロック機構を解除して行う。)	コンタクト ハウジング コネクタ 4. 9N(0.5kgf) 以下 58. 8N(6kgf) 以下 98N(10kgf) 以下

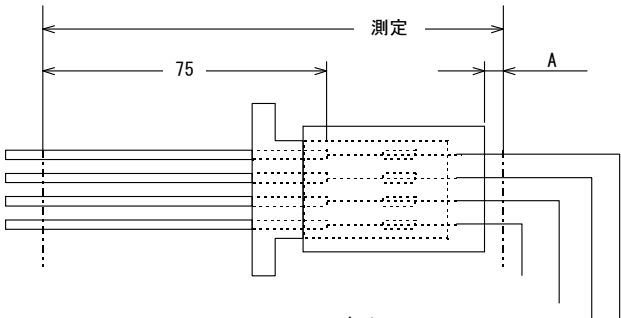
番号	項目	測定方法	性能								
7.5	低電圧電流抵抗	<p>図1に示す様に、嵌合したコネクタに開放時 $20 \pm 5\text{mV}$、短絡時 $10 \pm 0.5\text{mA}$ 通電し、圧着部より各75mm離れた点で測定する。電線の電圧降下分は差引く。(電線の抵抗値は表1による)</p> <p>図1 (Aは最少にする)</p>  <p>表1</p> <table border="1" data-bbox="535 1176 885 1381"> <thead> <tr> <th>電線サイズ</th> <th>抵抗値 ($\text{m}\Omega / 75\text{mm}$)</th> </tr> </thead> <tbody> <tr> <td>0.5</td> <td>2.45</td> </tr> <tr> <td>0.85</td> <td>1.56</td> </tr> <tr> <td>1.25</td> <td>1.07</td> </tr> </tbody> </table>	電線サイズ	抵抗値 ($\text{m}\Omega / 75\text{mm}$)	0.5	2.45	0.85	1.56	1.25	1.07	<p>初期 : $5\text{m}\Omega$ 以下</p> <p>耐久試験後 : $10\text{m}\Omega$ 以下</p>
電線サイズ	抵抗値 ($\text{m}\Omega / 75\text{mm}$)										
0.5	2.45										
0.85	1.56										
1.25	1.07										

番号	項目	測定方法	性能
7.6	絶縁抵抗	<p>コネクタを嵌合した状態で、図2の様に隣接するコンタクト相互間及びコンタクトとアース間の絶縁抵抗をDC500Vの絶縁抵抗計で測定する。</p> <p style="text-align: center;">図 2</p>	100MΩ 以上
7.7	耐電圧	<p>コネクタを嵌合した状態で、図2の様に隣接するコンタクトと相互間及びコンタクトとアース間に商用周波数の交流電圧1000V または、直流電圧1600Vを1分間加える。</p>	絶縁破壊がないこと。

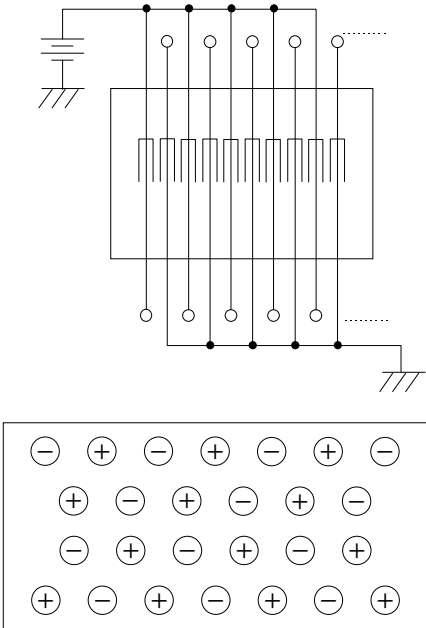
番号	項目	測定方法	性能
7.8	リーク電流	<p>図3の回路でDC28Vの電圧を印加し、リーク電流のピーク値と積算量を測定する。電線は装着可能な最小サイズを使用する。</p> <p>図3</p> 	<p>ピーク値 : 100 μ A以下</p>

番号	項目	測定方法		性能
7.9	コンタクト 半田付性	はんだ槽 : Sn-40Pb 半田温度 : 235±5°C 半田浸漬時間 : 5±0.5秒 使用フラックス : アルファ-100 AMP規格109-5203	マット錫めっき品のみ はんだ槽 : Sn-3Ag-0.5Cu 半田温度 : 250±5°C 半田浸漬時間 : 5±0.5秒 使用フラックス : ULF-300R	半田ぬれ面積率 : (めっき面のみ) 95%以上 (下地めっき有り)
7.10	コンタクト装着性 (コンタクト -ハウジング間)	任意の長さの電線を圧着したりセプタクルコンタクトをプラグハウジング 正規装着位置まで押し込む。保持する部分は、圧着部より約20mmはなれた電 線部とし、約100mm/min. 以下の一定の速度とする。		電線の曲がりがなく装着できること。
7.11	コンタクト脱却性 (コンタクト -ハウジング間)	7.10で装着されたコンタクトを同条件で引抜く。		有害な引っ掛かり、傷、変形がないこと。
7.12	コンタクト保持力 (コンタクト -ハウジング間)	プラグハウジングコネクタに約100mmの長さの電線を圧着したりセプタクル コンタクトを装着固定し、電線を軸方向に約100mm/min. の一定の速度で引っ 張り、コンタクトがハウジングから抜けるときの荷重を測定する。		58.8N(6kgf) 以上
7.13	コンタクト 圧着部強度 (コンタクト -電線間)	約100mmの長さの電線を圧着したりセプタクルコンタクトを固定し、電線を 軸方向に約100mm/min. の一定の速度で引っ張り、電線が破断あるいは圧着部 から電線が引き抜けるときの荷重を測定する。		電線サイズ 0.5 88.2N (9kgf) 以上 0.85 127.4N (13kgf) 以上 1.25 176.4N (18kgf) 以上

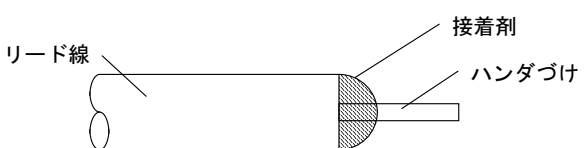
番号	項目	測定方法	性能
7.14	ハウジング保持力 (ハウジング ロック強度)	キャップハウジングコネクタを固定し、嵌合したプラグハウジングを軸方向に約100mm/min. の一定の速度で引っ張る。	98N(10kgf)以下の値でロック機構が離脱したり、破損したりしてはいけない。
7.15	シール性	<p>コネクタの防水箇所へ圧縮空気を送りコネクタのシール性を調べる。 電線は装着可能な最小サイズを使用し、先端はハンダづけ後接着剤で密封する(図4)か、ループを作り密封する。 測定は、コネクタを水中に入れ9.8KPa(gage)(0.1kg/cm²)の圧縮空気を30秒間送る。30秒間空気がもれない場合、9.8KPa(gage)(0.1kg/cm²)ずつ上げる。</p> <p style="text-align: center;">図 4</p> 	<p>初期 : 98KPa(gage) (1kg/cm²)以上</p> <p>耐久試験後 : 49KPa(gage) (0.5kg/cm²)以上</p>

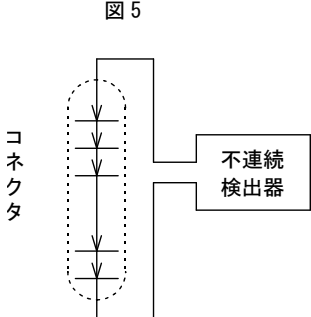
番号	項目	測定方法	性能
7.16	温度上昇値	コネクタに各耐久試験に基づく電流を通电し、温度が飽和したときのコンタクト圧着部の表面の温度を測定する。	上昇値60°C以下
7.17	瞬断	嵌合したコネクタを全極直列に接続して、開放時電圧12V以下、短絡時電流1A以下の電流を通电し、不連続検出器で瞬断を監視する。(図5) <div style="text-align: center; margin-top: 20px;"> <p>図 5</p>  </div>	10 μ sec以上の瞬断がないこと。

8. 試験構成及び順序

8.1 特性試験

試験は、原則として表3に従い行う。

表3

供試品	コンタクト	ハウジング	コネクタ
1	外観	外観	外観
2	挿入力	挿入力	コンタクト装着性
3	離脱力	離脱力	挿入力
4	挿入離脱の フィーリング	挿入離脱の フィーリング	離脱力
5	圧着部強度	ハウジング保持力	挿入離脱のフィーリング
6	—	—	コンタクト脱却性
7	—	—	コンタクト保持力
8	—	—	コンタクト半田付性

8.2 耐久試験

試験は、原則として表4に従い行う。

表4

順序 グループ	試験前	試験 I	試験 II	試験 III
A	—	こじり耐久	高温振動	カレントサイクル
	低電圧電流抵抗	低電圧電流抵抗 外観	瞬断※ 外観※ 低電圧電流抵抗	低電圧電流抵抗 外観
B	—	こじり耐久	温度上昇	/
	低電圧電流抵抗	低電圧電流抵抗 外観	温度上昇値※ 低電圧電流抵抗	
C	—	高温放置	低温放置	/
	挿入力 低電圧電流抵抗 シール性 離脱力	低電圧電流抵抗 シール性 離脱力 挿入力	低電圧電流抵抗 シール性 離脱力 挿入力	
D	—	サーマルショック	耐水	/
	挿入力 低電圧電流抵抗 シール性 離脱力	低電圧電流抵抗 シール性 離脱力 挿入力	リーク電流※ 低電圧電流抵抗 シール性 離脱力 挿入力	
E	—	過電流通電	/	/
	外観	外観		
F	—	こじり耐久	耐塵	耐油、耐溶液
	挿入力 低電圧電流抵抗 絶縁抵抗 離脱力	低電圧電流抵抗 外観	低電圧電流抵抗	低電圧電流抵抗 絶縁抵抗 離脱力 挿入力 外観
G	—	凍結	腐食ガス	オゾン劣化
	低電圧電流抵抗 絶縁抵抗 シール性	リーク電流※	低電圧電流抵抗 シール性	低電圧電流抵抗 絶縁抵抗 シール性 外観
H	—	塩害	/	/
	低電圧電流抵抗	リーク電流※ 低電圧電流抵抗		

順序 グループ	試験前	試験 I	試験 II	試験 III
I	—	耐候性		
	挿入力 低電圧電流抵抗 絶縁抵抗 耐電圧 離脱力	低電圧電流抵抗 絶縁抵抗 耐電圧 離脱力 挿入力		
J	—	耐高圧洗浄		
	外観	リーク電流※ 外観		

- 注： 1. 上段が試験項目で下段が測定項目である。
2. 測定項目は、上から順に下へ測定し、※印は試験中連続して測定する。
また、測定項目毎に試料を分けてもよい。

9. 試験方法

9.1 こじり耐久試験

キャップハウジングコネクタを固定し、プラグハウジングコネクタを正規に嵌合した状態で図6に示す要領で、前後方向に手指により約78.4N(8kgf)の力を2回加える。これを端子が抜けるまで1mmずつ引き抜いて行く。以上を1サイクルとして25サイクル行う。さらに、左右方向についても前後方向と同様に行う。(前後左右同時に実施してもよい。)

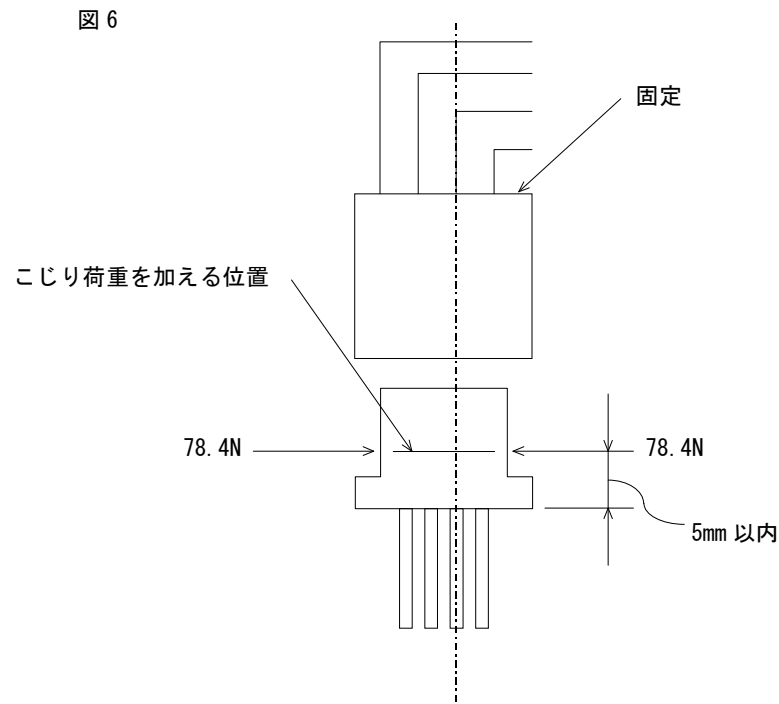

9.2 高温放置試験

恒温槽内にコネクタを1000時間放置し、その後取り出して常温に戻るまで放置する。なお、恒温槽内の温度は125°Cとする。

9.3 低温放置試験

恒温槽内にコネクタを150時間放置し、その後取り出して常温に戻るまで放置する。なお、恒温槽内の温度は-40°Cとする。

9.4 サーマルショック試験

コネクタを恒温槽内に入れ、図7に示す冷熱パターンを1サイクルとして200サイクル行い、その後取り出して常温にて2時間以上放置する。

図 7

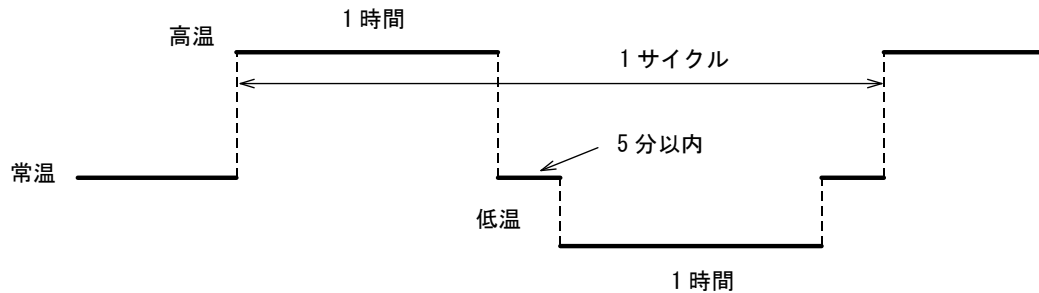

なお、恒温槽内の温度は、高温125°C、低温-40°Cとする。

9.5 塩害試験

密閉タンク内にコネクタを吊るし、温度 $35 \pm 5^\circ\text{C}$ 、塩水濃度 $5 \pm 1\%$ 、比重 $1.0268 \sim 1.0413$ 、PH $6.5 \sim 7.2$ の塩水を $68.6 \sim 176.5\text{KPa (gage)}$ ($0.7 \sim 1.8\text{kg/cm}^2$) の圧力で96時間噴霧させ、その後コネクタを湿度槽内に吊るし、 $80 \pm 5^\circ\text{C}$ 、湿度 $90 \sim 95\%RH$ で96時間放置する。

その後常温で乾燥後測定をする。塩水噴霧中は、コネクタ各極間に図3に示す回路で28Vの電圧を印加し、リーク電流を監視する。

9.6 耐油、耐溶液試験

コネクタを各種オイルに浸漬する。オイルの温度は $50\pm 2^{\circ}\text{C}$ とし、順序を以下に示す。

- トルコンオイル
(キャスルオートフルードスペシャル) 1時間浸漬 → 白灯油洗浄5分間浸漬
- ミッションオイル (SAE 90) 1時間浸漬 → 白灯油洗浄5分間浸漬
- エンジンオイル (SAE 10W-30) 1時間浸漬 → 白灯油洗浄5分間浸漬
- クラッチオイル (トヨタ規格 SHD) 1時間浸漬 → 白灯油洗浄5分間浸漬
- ブレーキオイル (トヨタ規格 SHF) 1時間浸漬 → 白灯油洗浄5分間浸漬

また、別のサンプルを用いて、以下の溶液に浸漬する。溶液の温度は $50\pm 2^{\circ}\text{C}$ とし、順序を以下に示す。

- ウォッシュ液 (市販品) 1時間浸漬 → 水道水洗浄5分間浸漬
- 不凍液 (キャスルロングライフクーラント) 1時間浸漬
- 水道水洗浄5分間浸漬 → 常温放置にて乾燥

9.7 耐水試験

コネクタを恒温槽内に入れ、40分間加熱し、その後直ちに耐水試験槽内に入れ20分間常温水を噴水する。

これを1サイクルとして48サイクル実施する。噴水条件は、JIS D0203のS2とする。噴水中は、コネクタの各極間に図3に示す回路で28Vの電圧を印加し、リーク電流を監視する。

また、恒温槽内の温度は、 125°C とする。

9.8 凍結試験

コネクタを 100°C の水に1時間浸漬後、これを速やかに $-30\pm 5^{\circ}\text{C}$ の恒温槽に入れ、付着した水が氷結した後、取り出す。試験中は、コネクタの各極間に図3に示す回路で28Vの電圧を印加し、リーク電流を監視する。

9.9 腐食ガス

コネクタを亜硫酸ガス (SO₂) 濃度10ppm、湿度90%以上、常温の試験槽内に24時間放置する。

9.10 オゾン劣化試験

コネクタをオゾン濃度50±5pphm、温度40°Cの試験槽内に24時間放置する。

9.11 高温振動試験

図8のように、コネクタを振動台に取り付け、温度125°Cの雰囲気中で振動を加える。加振方向は、X、Y、Zの3方向とする。その他の加振条件は、表5による。試験中は、コネクタに図5に示す回路で通電し、瞬断を監視する。

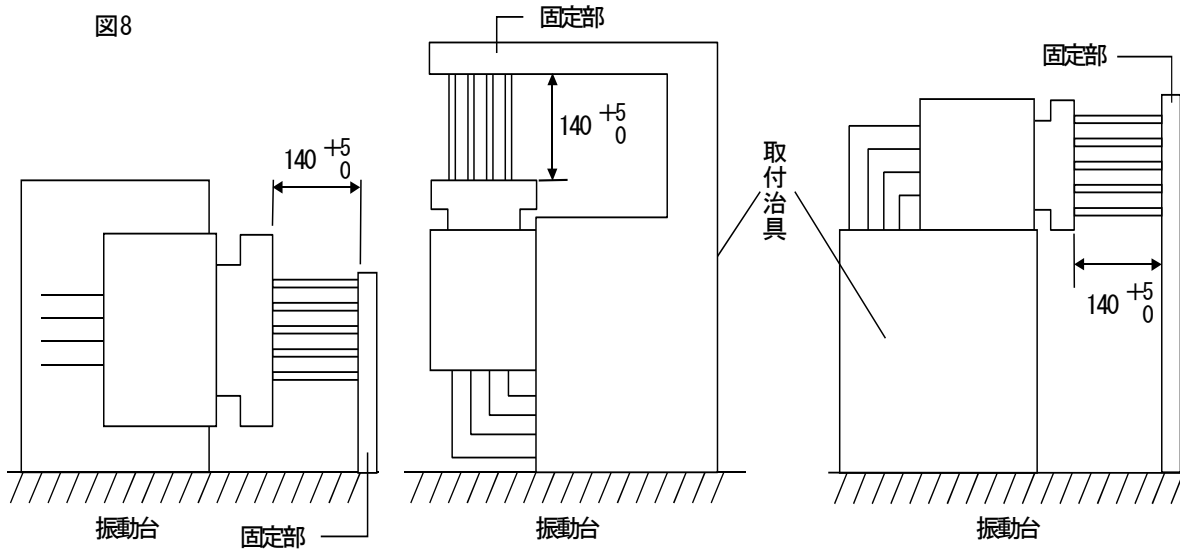

ケーブル長さは、150 ⁺⁵/₀ mmとする。

表5

加速度 (m/s ²)	加振時間 (h)	加振周波数 (Hz)
98~245 (10~25G)	各3 計9	50~100 ... 98m/s ² (10G)一定 100~250* ... 片振巾 0.2mm一定~245m/s ² (25G)一定 掃引時間 3分 (Log Sweep)

* 100~176~250Hz

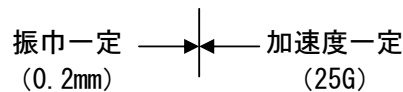

9.12 耐候性試験

コネクタを日光のよく当る屋外に、12か月放置する。

9.13 カレントサイクル試験

- ① コネクタに信号部 3A、パワー部 4Aの電流を全極に通電する。通電方法は45分間通電、15分間休止を1サイクルとし、これを200サイクル行う。
- ② 温度120°Cの雰囲気中でコネクタに信号部 3A、パワー部 8Aの電流を図9の例のごとく1極飛びに通電し、これを50サイクル行う。試験中は無風状態とし、表5の条件で振動を加える。加振方向はコンタクト軸に垂直なコネクタ長辺方向とする。

図9

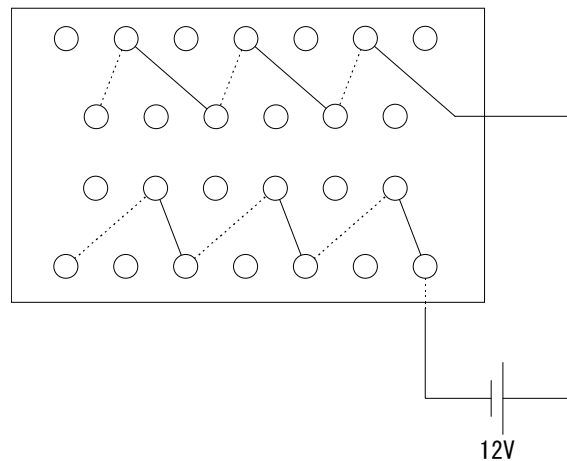

9.14 過電流通電試験

コネクタを無風状態の所で水平に保ち、任意の1回路に通電する。通電する電流値および通電時間は表6による。

表6

電線 サイズ	試験 ①		試験 ②	
	電流値 (A)	通電時間 (min.)	電流値 (A)	通電時間 (sec.)
0.5	30	5	80	5
0.85	40		110	
1.25	50		170	

9.15 耐塵試験

縦・横・高さが900~1200mmの密封タンク内にコネクタを吊るし、JIS Z 8906の6種に規定された粉体 1.5kgを15分ごとに、10秒間圧縮空気を噴射させ、ファン等で一様に拡散させる。これを1サイクルとし、8サイクル行う。
なお、2サイクル終了ごとにコネクタの離脱、挿入を1回行う。

9.16 温度上昇試験

コネクタに15Aの電流を任意の1極に通電する。その後、6Aの電流を全極に通電する。測定は、7.16 温度上昇値に基づき行う。

9.17 耐高圧洗浄試験

コネクタを恒温槽内で100°Cに保温（10分以上）後、直ちに表7の条件で洗浄を行う。その後、1分程度自然冷却する。これを1サイクルとして10サイクル実施する。洗浄は、図10のように固定したコネクタの嵌合方向に対し、60°の角度から

A: 電線防水部

B: 嵌合防水部

をねらう。(AとBは別サンプルとする。)

図10

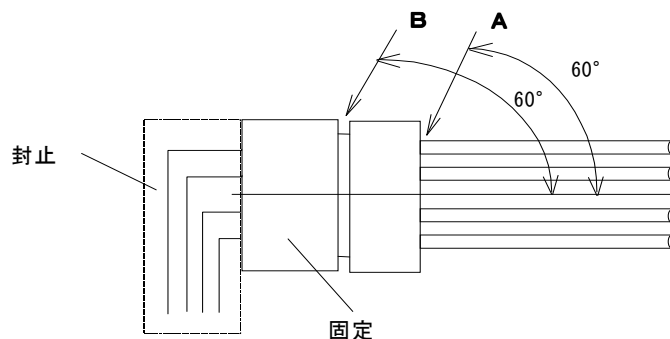

洗浄中は、コネクタの各極間に図3に示す回路で28Vの電圧を印加し、リーク電流を監視する。

表7

項目	条件
吐出水圧	784. 532N/cm ² (洗浄機設定値)
吐出水量	600ℓ/h以上
ノズルからの距離	300mm
洗浄時間	30 sec

10. 試験条件

- (1) 試験に使用するコンタクト及びコネクタは、ランダムに抜き取ったものとする。
- (2) 試験に使用するコンタクトに取りつける電線は、指示ある場合を除き、装着可能な最大サイズの電線を取り付けるものとし、長さはその都度決定する。
- (3) 試験に使用する電線は、試験に規定する温度条件に対し十分な耐熱性を有し、又、各溶媒に対し著しい絶縁抵抗の劣化が生じない被覆材質を用いること。
- (4) 試験は、指示ある場合を除き常温常湿で行うものとする。
- (5) 試験は、指示ある場合を除きコネクタを嵌合させた状態で行うものとする。
- (6) 試験条件中の公差は、指示のない場合は±10%とする。
- (7) 試料数は、その都度決定する。
- (8) 各試験の測定は、2極以上行うこと。

11. 梱包及び表示

梱包形態は、適切な数量を1ユニットとして運搬及び保管に際して損傷のないよう荷造りを施して次の内容を明示する。

- ・ 品名またはカタログNo.
- ・ 数量
- ・ 製造社名または略名
- ・ 製造年月日またはロットNo.