

REV	DATE	DESCRIPTION	BY	CHK	APP
A		RELEASED PER ECO-10-000080	TRUMPH	CR	MS
B		REVISED PER ECO-10-015148	ZWETSH	CJV	JRP

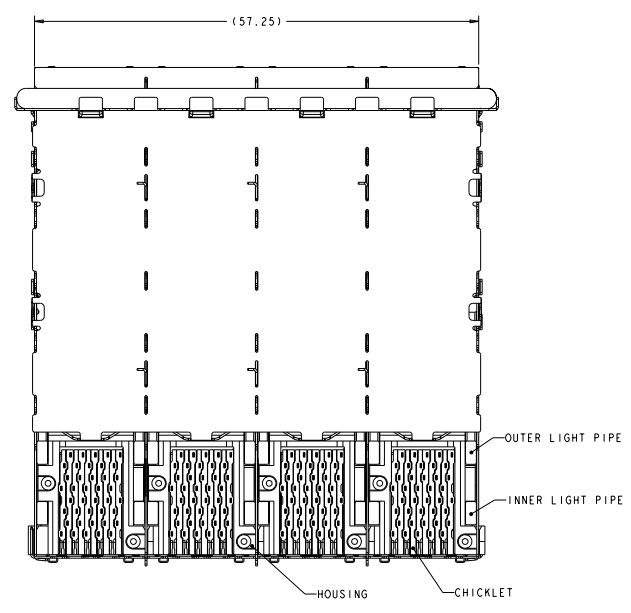
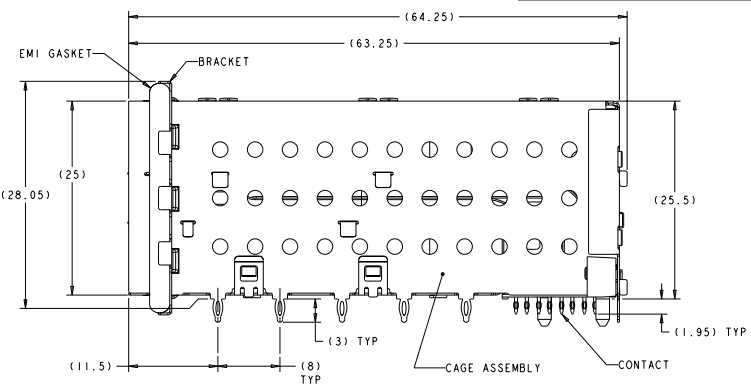
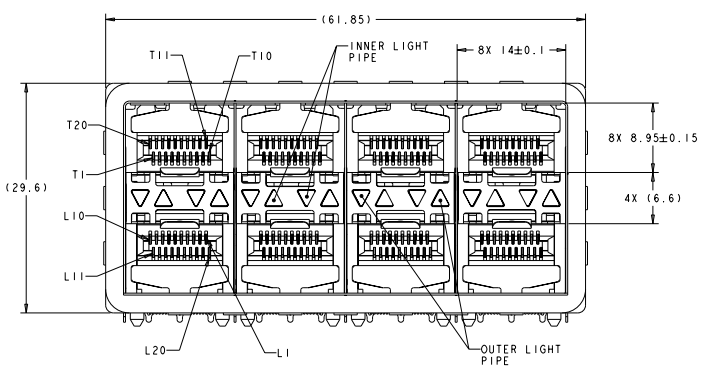

- △ MATERIALS:
 CAGE ASSEMBLY- NICKEL SILVER ALLOY PER ASTM B 122.
 BRACKET- STAINLESS STEEL.
 EMI GASKET- PLATED FILLED SILICONE.
 HOUSING- BLACK LCP, UL 94V-0 RATED.
 CHICKLET- BLACK LCP, UL 94V-0 RATED.
 LIGHT PIPE- POLYCARBONATE, CLEAR, UL 94V-2 RATED.
 INSERT - (FOR LIGHT PIPE PART NUMBERS ONLY) - PBT, BLACK, UL 94V-0
 CONTACT- COPPER ALLOY.
- △ DATUM AND BASIC DIMENSIONS ESTABLISHED BY CUSTOMER.
- 3. MINIMUM PCB THICKNESS OF 1.5.
- △ CONTACT FINISH: CONFORMS TO THE REQUIREMENTS OF TYCO ELECTRONICS PRODUCT SPECIFICATION 108-2331, BASED ON EIA/ECA-364-1000.01A, (CONTROLLED ENVIRONMENT APPLICATIONS) ON MATING INTERFACE, TIN-LEAD ON NEEDLE EYE.
- △ CONTACT FINISH: CONFORMS TO THE REQUIREMENTS OF TYCO ELECTRONICS PRODUCT SPECIFICATION 108-2331, BASED ON EIA/ECA-364-1000.01A, (CONTROLLED ENVIRONMENT APPLICATIONS) ON MATING INTERFACE, TIN ON NEEDLE EYE.
- △ FOR HOLE SIZE AND PLATINGS, SEE APPLICATION SPEC 114-13219.
- △ THE ENTIRE AREA OF THE CONNECTOR FOOTPRINT, INDICATED BY THE DASHED LINE, TO BE CONSIDERED THE KEEPOUT AREA FOR COMPONENTS AND SIGNAL TRACES, TOP SIDE ONLY. TOP SIDE TRACES ALLOWED WITHIN CONNECTOR HOLE PATTERN.
- △ LIGHT PIPE PAD LAYOUT IS FOR 0805 LOW PROFILE LED PACKAGE WITH A HEIGHT OF 0.8mm.

△	NO LIGHT PIPES	2007399-8
	OUTER 2 LIGHT PIPES	2007399-7
	INNER 2 LIGHT PIPES	2007399-6
△	4 LIGHT PIPES	2007399-5
	NO LIGHT PIPES	2007399-4
	OUTER 2 LIGHT PIPES	2007399-3
	INNER 2 LIGHT PIPES	2007399-2
	4 LIGHT PIPES	2007399-1

FINISH	DESCRIPTION	PART NUMBER

TYCO ELECTRONICS CORPORATION
 10072007
 10072007
 10072007
 108-2331
 114-13219
 00779 © 2007399
 CUSTOMER DRAWING

TYCO ELECTRONICS
 Harrisburg, PA 17105-3600
 CAGE AND PT CONNECTOR ASSEMBLY,
 WITH EMI GASKET,
 PRESS FIT, 2X4, STACKED SFP.

STATE CASE CODE (RELATING TO)
 A | 00779 © 2007399

DATE: 4-11-07

REV	DATE	DESCRIPTION	BY	CHK	APP
00		SEE SHEET 1			

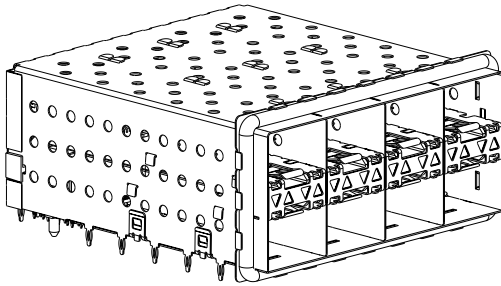

2007399-1 AND 2007399-5
 SCALE 3:1

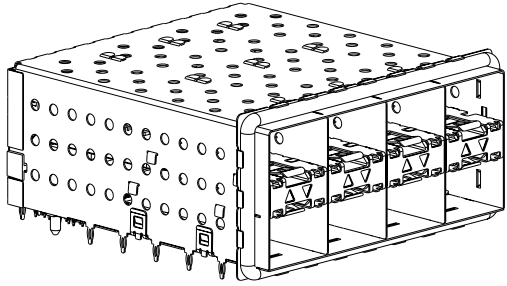

2007399-2 AND 2007399-6
 SCALE 3:1

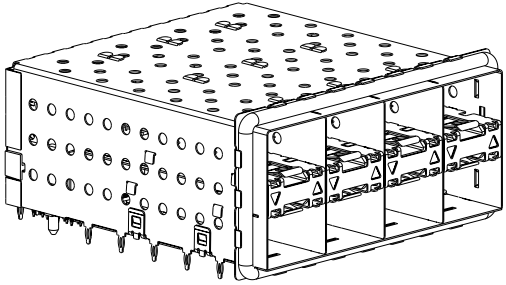

2007399-3 AND 2007399-7
 SCALE 3:1

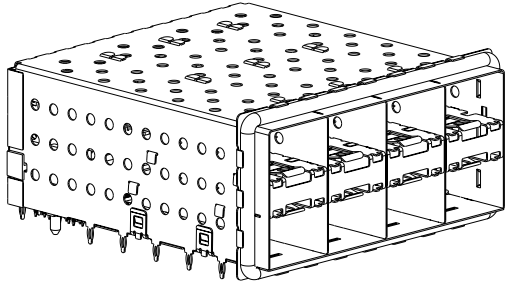

2007399-4 AND 2007399-8
 SCALE 3:1

TITLE BLOCK 2007399-1 AND 2007399-8 CAGE AND PT CONNECTOR ASSEMBLY.		DATE: 10072007 BY: SUCSENY CHECKED: 10072007 100-2231 114-13219		Tech Electronics Harrisburg, PA 17105-3600	
PART NUMBER: 2007399-1 AND 2007399-8 QUANTITY: 1000 UNIT: 1000 PRICE: 114-13219		CAGE AND PT CONNECTOR ASSEMBLY. WITH EMI GASKET. PRESS FIT, 2X4, STACKED SFP.		STATE: PA CITY: HARRISBURG ZIP: 17105-3600 PHONE: 717-631-1000 FAX: 717-631-1001 WWW: WWW.TECH-ELECTRONICS.COM	
CUSTOMER DRAWING		A 00779 2007399		SHEET 2 OF 4	

REV	DATE	DESCRIPTION	BY	CHK	APP
00		SEE SHEET 1			

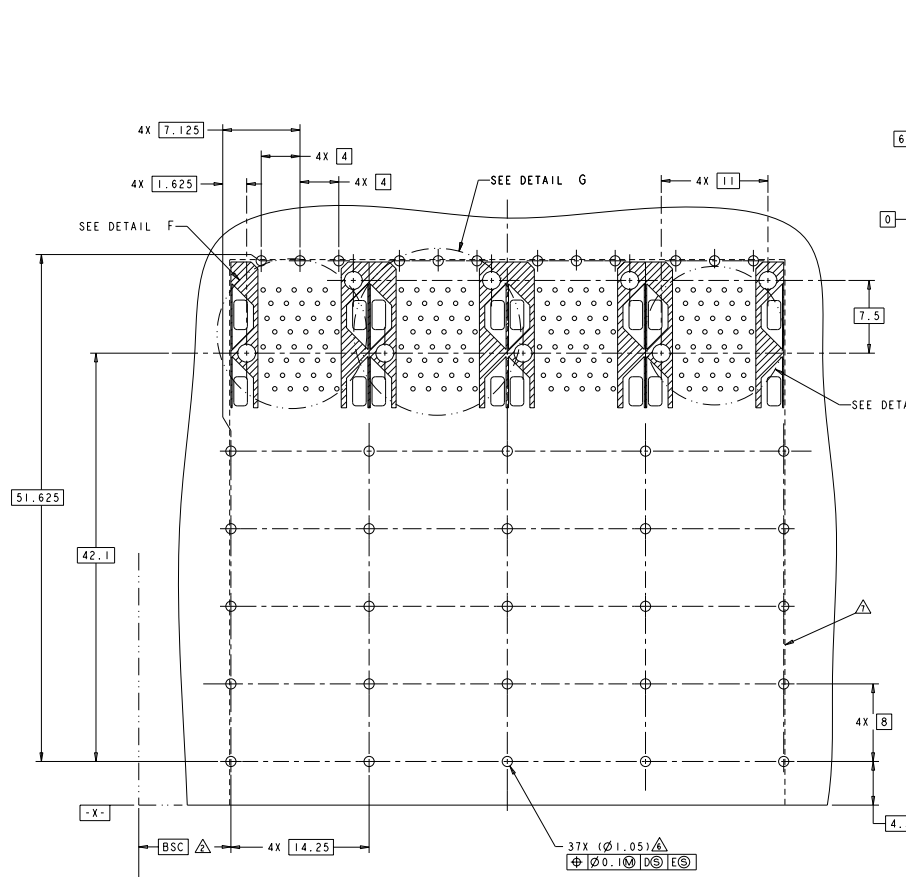

RECOMMENDED PCB LAYOUT
 COMPONENT SIDE OF BOARD
 SCALE 5:1

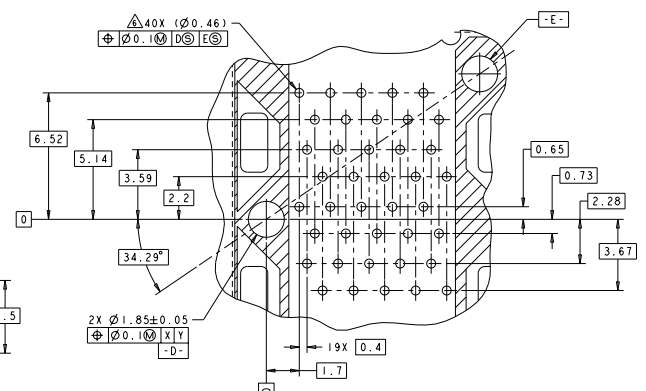

DETAIL F
 4X INDIVIDUALLY
 SCALE 10:1

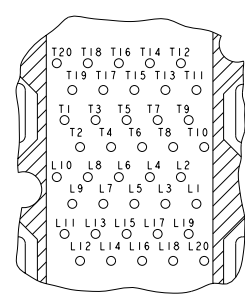

DETAIL H
 CONNECTOR PIN-OUT
 COMPONENT SIDE OF BOARD
 SCALE 10:1

TITLE: CAGE AND PT CONNECTOR ASSEMBLY PART NO: 10072007 REV: 00 DATE: 10/18/00 DRAWN BY: J. SULLIVAN CHECKED BY: J. SULLIVAN APPROVED BY: J. SULLIVAN DATE: 10/18/00	TITLE: CAGE AND PT CONNECTOR ASSEMBLY PART NO: 10072007 REV: 00 DATE: 10/18/00 DRAWN BY: J. SULLIVAN CHECKED BY: J. SULLIVAN APPROVED BY: J. SULLIVAN DATE: 10/18/00	TITLE: CAGE AND PT CONNECTOR ASSEMBLY PART NO: 10072007 REV: 00 DATE: 10/18/00 DRAWN BY: J. SULLIVAN CHECKED BY: J. SULLIVAN APPROVED BY: J. SULLIVAN DATE: 10/18/00	TITLE: CAGE AND PT CONNECTOR ASSEMBLY PART NO: 10072007 REV: 00 DATE: 10/18/00 DRAWN BY: J. SULLIVAN CHECKED BY: J. SULLIVAN APPROVED BY: J. SULLIVAN DATE: 10/18/00
---	---	---	---

REV	DATE	DESCRIPTION	BY	CHK	APP
GP 00		SEE SHEET 1			

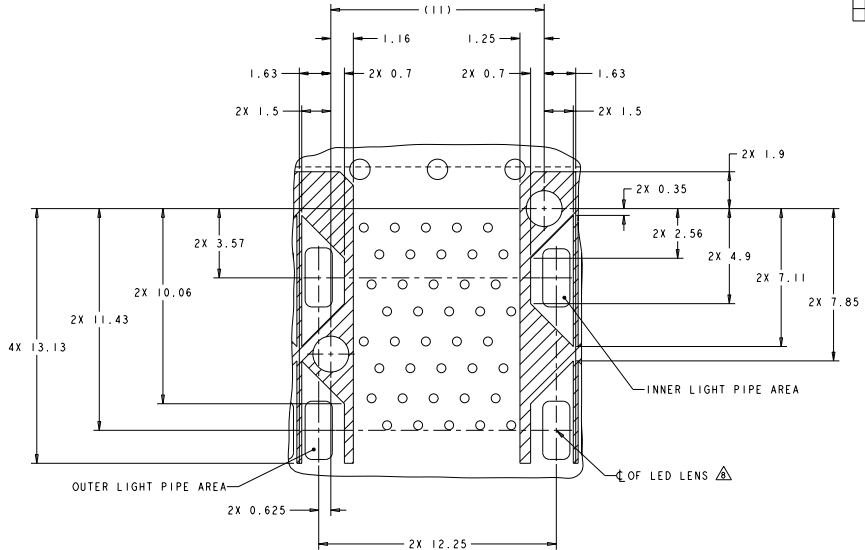

DETAIL G
 CONNECTOR HOUSING
 KEEPOUT ZONE
 4X INDIVIDUALLY
 SCALE 10:1

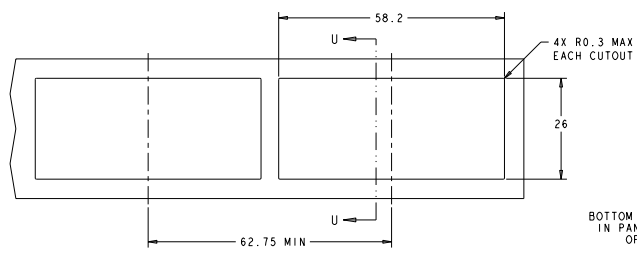

RECOMMENDED PANEL CUTOUT
 AND PC BOARD, PANEL POSITION
 SCALE 2:1

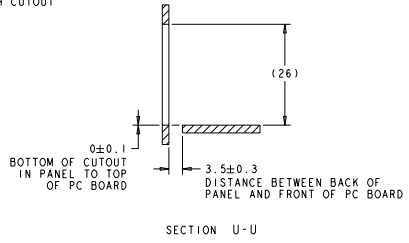

SECTION U-U

TTI ELECTRONICS CORPORATION 10000 WILSON BOULEVARD WILKES BARRE, PA 18209 TEL: 717-261-0000 FAX: 717-261-0001 WWW.TTI.COM		100C72007 TTI ELECTRONICS Harrisburg, PA 17105-3608	
ORDER NUMBER: 100C72007 PART NUMBER: 100C72007 QUANTITY: 1000 ORDER DATE: 10/23/2018 QUOTE VALID THRU: 11/6/2018 PRICE: -	CAGE AND PT CONNECTOR ASSEMBLY, WITH EMI GASKET PRESS FIT, 2X4, STACKED SFP+	STATE: PA CITY: WILKES BARRE ZIP: 18209 COUNTRY: USA CUSTOMER DRAWING: A	PART NUMBER: 100C72007 QUANTITY: 1000 ORDER DATE: 10/23/2018 QUOTE VALID THRU: 11/6/2018 PRICE: - CUSTOMER DRAWING: A