

4

3

2

1

THIS DRAWING IS UNPUBLISHED.

RELEASED FOR PUBLICATION

20

© COPYRIGHT 20

BY TYCO ELECTRONICS CORPORATION.

ALL INTERNATIONAL RIGHTS RESERVED.

LOC	DIST	REVISIONS					
B	E	P	LTR	DESCRIPTION	DATE	DWN	APVD

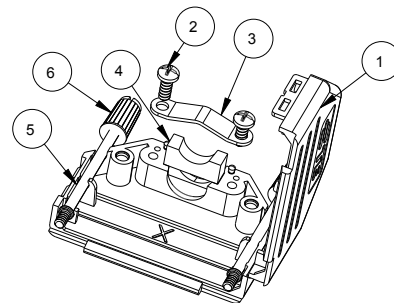
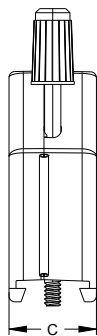
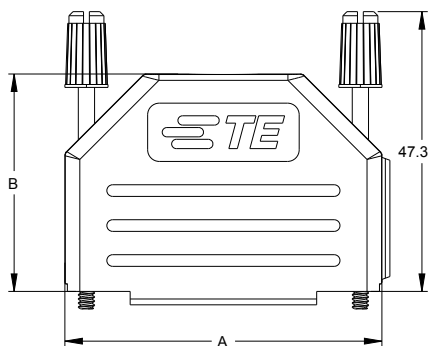

1 BULK PACKAGED SHELL ASSEMBLIES.
SHELL ASSEMBLY COMPONENTS PACKAGED SEPERATELY
IN BAGS. 100 COMPONENT SETS PER BAG.

2. TEMPERATURE RANGE -55C - +105C

3. CABLE DIAMETER 3.0 - 11.0mm

1	15.0	36.0	70.9	SELF TAPPING	4-40 UNC	4	37	BLACK	3-1991253-7
1	15.0	37.3	54.4	SELF TAPPING	4-40 UNC	3	25	BLACK	2-1991253-5
1	15.0	30.8	40.7	SELF TAPPING	4-40 UNC	2	15	BLACK	1-1991253-5
1	15.0	31.3	32.4	SELF TAPPING	4-40 UNC	1	9	BLACK	1991253-9
PACKAGING	DIM C	DIM B	DIM A	FIXING SCREW TYPE	JACKSCREW THREAD	SHELL SIZE	POSITION	COLOUR	PART NO

THIS DRAWING IS A CONTROLLED DOCUMENT FOR TYCO ELECTRONICS CORPORATION.
IT IS SUBJECT TO CHANGE AND THE CONTROLLING ENGINEERING ORGANIZATION
SHOULD BE CONTACTED FOR THE LATEST REVISION.

DWN 05JAN2011

M.GREENER

CHK 05JAN2011

J.AMBROSE

APVD 05JAN2011

PRODUCT SPEC

APPLICATION SPEC

WEIGHT

CUSTOMER DRAWING

Tyco Electronics UK Ltd.
Bideford, North Devon, EX39 4HE

LOW COST PLASTIC
D-SUB BACKSHELL

SIZE A3
CAGE CODE 00779

DRAWING NO C-1991253

RESTRICTED TO

SCALE NTS

SHEET 1 OF 1

REV A

6	JACKSCREW KNOB	POLYAMIDE UL94 V2		2
5	JACKSCREW	CARBON STEEL	ZINC	2
4	CABLE CLAMP BASE	POLYAMIDE UL94 V2		1
3	CABLE CLAMP	CARBON STEEL	ZINC	1
2	FIXING SCREW	CARBON STEEL	ZINC	2
1	BACKSHELL BODY	POLYAMIDE UL94 V2		1
ITEM	DESCRIPTION	MATERIAL	FINISH	QTY

DIMENSIONS:

mm

TOLERANCES UNLESS OTHERWISE SPECIFIED:

0 PLC ± 0.5

1 PLC ± 0.5

2 PLC ± 0.5

3 PLC ± 0.5

4 PLC ± 0.5

ANGLES ± 0.5

FINISH -

MATERIAL SEE TABLE

1470-19 (2/09)