

DO NOT SCALE
DIMENSIONS IN mm

METRIC



NOTES:

- ▲ FOR MINI-APPLICATOR-CRIMPING.
- ▲ UNDERCOATING: 1,25µm Ni, SELECTIVE: 0,8µm Au, ZONE 1: 0,5µm MIN. GOLDFLASH.
- ▲ UNDERCOATING: 1,25µm Ni, SELECTIVE: 0,8µm Au, REMAINDER: GOLDFLASH.
- ▲ UNDERCOATING: 1,25µm Ni, SELECTIVE: 0,4µm Au, NO GOLDFLASH.
- ▲ ZONE 1: BRIGHT TIN/LEAD PLATED.
- 6 MATERIAL: PHOSPHORBRONZE
- ▲ FOR STANDARD-APPLICATOR-CRIMPING.
- ▲ FOR REEL-FED-HANDTOOL-CRIMPING, 500 CONTACTS ON A SMALL REEL.
- ▲ 24-20 AWG (0,20-0,56 mm²) WITH .055 CRIMPER.
- ▲ 26 AWG (0,12-0,14 mm²) WITH .042 CRIMPER.

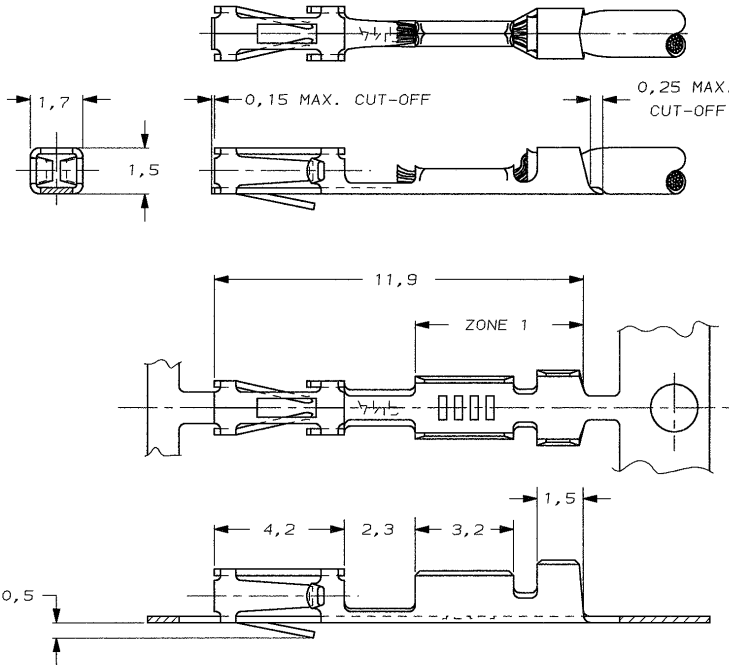

GOLD	▲	141603-4	5-167300-8	▲
GOLD	▲	≠	1-167300-6	▲
			1-167300-5	▲
GOLD	▲	141603-4	167300-8	▲
			167300-7	▲
GOLD	▲	141603-3	167300-6	▲
			167300-5	▲

		FINISH		LOOSE PIECE	PARTNUMBER
-	-	-	-	-	-
CUSTOMER DRAWING FOR REFERENCE ONLY WILL NOT BE UPDATED					
© COPYRIGHT 19- BY AMP HOLLAND B.V.					
ALL INTERNATIONAL RIGHTS RESERVED. AMP PRODUCTS MAY BE COVERED BY U.S. AND FOREIGN AND/OR PATENTS PENDING.					
THIS DRAWING IS UNPUBLISHED					
RELEASED FOR PUBLICATION					
AMP					
NAME AMPMODU MOD.4 RECEPTACLE, STRIP					
F EH-2039-98		JvL	JvL	03-12-98	
LTR. REVISION RECORD		DR.	CHK.	DATE	
DR.:	J.v.LIEMPT	CHK.:	J.v.LIEMPT	APP.:	E.LEIJTENS
DATE:	03 DEC 98	DATE:	-	DATE:	-
		DWG.No.		C-167300	
		REV.LTR.		F	
		SHEET		1 OF 1	A3