

**Product Specification**  
**108-60036**  
**AMP Connector**  
**AMPLIMITE\* .050 Series I, Board to Board**  
**Lead Free Version**

**1. Scope:**

**1.1 Contents**

This specification covers the requirements for product performance, test methods and quality assurance provisions of AMPLIMITE\* .050 Series I, Board-to-Board Connector of the following part numbers.

Product No	Product Descriptions	Mounting Type	Remarks
X-5173277-X	Horizontal Plug Ass' y	Screw-on	
X-5173278-X	Horizontal Cap Ass' y	Screw-on	
X-5173279-X	Vertical Plug Ass' y	Screw-on	
X-5173280-X	Vertical Cap Ass' y	Screw-on	
X-5174207-X	Horizontal Plug Ass' y	Retention Leg	
X-5174214-X	Horizontal Cap Ass' y	Free Standing	
X-5174215-X	Vertical Plug Ass' y	Free Standing	
X-5174216-X	Vertical Cap Ass' y	Free Standing	
X-5174217-X	Horizontal Plug Ass' y	Retention Leg	
X-5174218-X	Horizontal Cap Ass' y	Retention Leg	
X-5174681-X	Vertical Plug Ass' y	w/Kink	
X-5174682-X	Horizontal Plug Ass' y	w/Kink	
X-5174683-X	Vertical Cap Ass' y	w/Kink	
X-5174684-X	Horizontal Cap Ass' y	w/Kink	
X-5175710-X	Vertical Plug Ass' y	w/Kink	
X-5175711-X	Vertical Cap Ass' y	w/Kink	
X-5178857-X	Vertical Cap Ass' y	w/Kink	w/Polarity Post (L, C, P)
X-5179359-X	Vertical Cap Ass' y	w/Kink	Side Cut Type

THIS INFORMATION IS CONFIDENTIAL AND IS DISCLOSED TO YOU ON THE CONDITION THAT YOU WILL NOT DISCLOSE OR REPRODUCE IT IN ANY MANNER TO OTHER THAN AMP PERSONNEL WITHOUT WRITTEN AUTHORIZATION FROM AMP SHANGHAI LTD

DR	C. WANG		<b>tyco</b> Electronics	Tyco Electronics AMP Shanghai Ltd	
	CHK	S. YAO			
APP	I. ENOMOTO		NO 108-60036	REV O	LOC ES
PAGE	TITLE				
1 of 7	AMP Connector, Amplimite*.050 Series I BTB Connector Lead Free Version				
O	RELEASED FB00-0268-04	C.W	20AUG		
LTR	REVISION RECORD	DR	DATE		

The difference of the thickness of gold-plating is classified by the prefix number, and the contact position is so with the suffix numbers.

Fig. 1

2. Type of the Products:

The type of the products and their state of application are shown below.

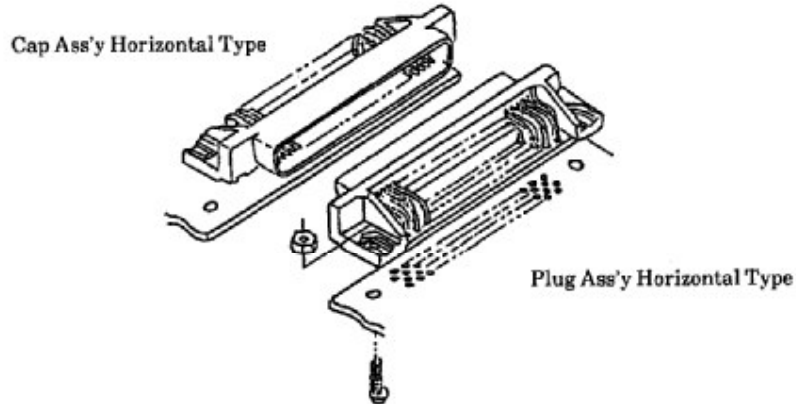

Fig. 2 Horizontal Type Connector

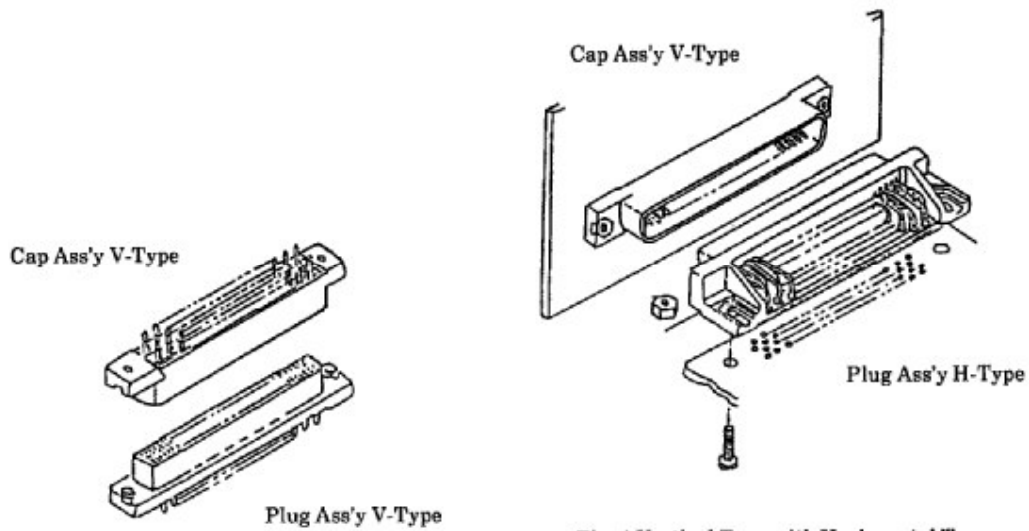

Fig. 3 Vertical Type

Fig. 4 Vertical Type with Horizontal Type

<p><b>tyco</b> Electronics</p>	<p>Tyco Electronics AMP Shanghai Ltd</p>	<p>PAGE 2</p>	<p>NO 108-60036</p>	<p>REV O</p>	<p>LOC ES</p>
------------------------------------	--	-------------------	-------------------------	------------------	-------------------

### 3. Applicable Documents:

The following documents form a part of this specification to the extent specified here in. In the event of conflict between the requirements of this specification and the product drawing, the product drawing shall take precedence. In the event of conflict between the requirements of this specification and the referenced documents, this specification shall take precedence.

#### 3.1 AMP Specifications:

A. 109-1 Test Specification, General Requirements for Test Methods

#### 3.2 Military Standard and Specifications:

MIL-STD-202 Test Methods for Electronic and Electrical Component Parts

#### 3.3 501-60015 : Product Qualification Test Report

### 4. Requirements:

#### 4.1 Structure, Shape and Dimension

The product structure, shape and dimensions shall conform to requirements shown on applicable drawing, unless other wise specified below.

(1) Number of Positions : ◦ 9 type in 20,30,34,40,48,50,60,68 and 96 positions

(2) Connector Type: ◦ Horizontal  
◦ Vertical

(3) Pitch and Row : ◦ Engaging Side: 1.27 mm pitch x2.54 mm in 2 rows  
◦ Board Side: 2.54 mm pitch x1.905 mm in zigzag of 4 rows

(4) Mounting on PCB: ◦ Screw-on (M2 Screws) Type  
◦ Free Standing Type  
◦ Retention Leg Type  
◦ With Kink Type

(5) Applicable PCB: ◦ Board Thickness: 0.8-1.6 mm with solder resistive agent applied on Solder side.

: The kink Type is 1.6 mm Thk only.

<b>tyco</b> Electronics	Tyco Electronics AMP Shanghai Ltd	PAGE 3	NO 108-60036	REV O	LOC ES
----------------------------	--------------------------------------	-----------	-----------------	----------	-----------

#### 4.2 Material and Finish:

##### 4.2.1 Receptacle Contact and post Contact:

- (1) Material: Phosphor Bronze
- (2) Finish: Underplating: 1.3  $\mu\text{m}$  min. Nickel Underplate all over
  - Gold-Plating... 0.2  $\mu\text{m}$  min. thick gold plated for 0-prefix  
(Contact Area) no. items, and 0.75  $\mu\text{m}$  min. thick for 6-prefix no.items.
  - Other Areas: Gold Flash Plated
  - Tine Soldering: 1.0  $\mu\text{m}$  min. Tin-plated

##### 4.2.2 Housing:

- (1) Material : ..... Fider Glass reinforced  
polybutyleneterephalate resin (P. B. T.)  
Colour: Black  
178854 & 178857: Liquid Crystal Polymer  
Colour: Black
- (2) Flame Retardancy ..... UL 94 V -0

##### 4.2.3 Retention Leg :

- (1) Material: ..... Brass
- (2) Finish : .....
  - 1.0  $\mu\text{m}$  min. thick nickel underplate all over
  - 2.0  $\mu\text{m}$  min. thick tin plating all over

#### 4.3 Appearance:

The connectors shall be free from the defects such as damage. Cracks, deformation, blister, dirt and burrs that are detrimental to connector functions and product merchandising value.

#### 4.4 Ratings:

- (1) Temperature Rating: ..... -55°C/+105°C
- (2) Current Rating: ..... 1 A max.
- (3) Voltage Rating: ..... 100V DC. Max.

<b>tyco</b> Electronics	Tyco Electronics AMP Shanghai Ltd	PAGE 4	NO 108-60036	REV O	LOC ES
----------------------------	--------------------------------------	-----------	-----------------	----------	-----------

4.5 Performance and Test Descriptions:

The product is designed to meet the electrical, mechanical and environmental performance requirements specified in Fig. 5. All tests are performed at ambient temperature unless otherwise specified.

4.6 Test Requirements and Procedures Summary:

Para.	Test Items	Requirements			Procedures	
4.6.1	Confirmation of Product	Product shall be conforming to the requirements of applicable product drawing.			Visually, dimensionally and functionally inspected per applicable inspection plan.	
Electrical Requirements						
4.6.2	Termination Resistance (Low Level)	Timing Combination		Initial Max.	After Test Max.	Subject mated contacts assembled in housing to closed circuit current of 10 mA max. at open circuit voltage of 50 mV max. Fig. 6.
		Horizontal-to-horizontal		25mΩ	50mΩ	
		Horizontal-to-vertical				
		Vertical-to-vertical		15mΩ	30mΩ	
4.6.3	Insulation Resistance	1000 MΩ min. (Initial) 500 MΩ min. (Final)		Measure by applying test potential between the adjacent contacts, and between the contacts and ground in the mated connector.  MIL-STD-202, Method 302, Condition B		
4.6.4	Dielectric Strength	No abnormalities such as insulation break-down or flashover shall take place during the test.		Measure by applying test potential between the adjacent contacts. In the mated connectors.  MIL-STD-202, Method 301		

Fig. 5 (To be continued)

<b>tyco</b> Electronics	Tyco Electronics AMP Shanghai Ltd	PAGE 5	NO 108-60036	REV O	LOC ES
----------------------------	--------------------------------------	-----------	-----------------	----------	-----------

Para.	Test Items	Requirements	Procedures
4.6.5	Temperature Rising vs. Current	30°C max. Under loaded specified current.	Measure temperature rising by energized current. Fig. 6
<b>Physical Requirements</b>			
4.6.6	Vibration Sinusoidal High Frequency	No electrical discontinuity greater than 1 microsecond (s) shall occur.	Subject mated connectors to 10-500-10 Hz traversed in 15 minutes with 10 G accelerated velocity; 2 hours each of 3 mutually perpendicular planes. MIL-STD-202, Method 204 Condition A
4.6.7	Physical Shock	No electrical discontinuity greater than 1 microsecond (s) shall occur.	Subject mated connectors to 50 G's halfsine shock pulses of 11 millisecond duration; 3 shocks in each direction applied along the 3 mutually perpendicular planes total 18 shocks; MIL-STD-202, Method 213 Condition A
4.6.8	Connector Mating Force	0.78N max. per contact	Using autograph, measure the force required to mate connectors by operating at 100 mm a minute. Record by using autograph. Calculate the value for a contact.
4.6.9	Connector Unmating Force	0.20N min. per contact	Using autograph, measure the force required to unmate connectors by operating at 100 mm a minute. Calculate value for a contact.

Fig. 5 (to be continued)

<b>tyco</b> Electronics	Tyco Electronics AMP Shanghai Ltd	PAGE 6	NO 108-60036	REV O	LOC ES
----------------------------	--------------------------------------	-----------	-----------------	----------	-----------

Para.	Test Items	Requirements	Procedures
4.6.10	Durability (Repeated Mate/Unmating)	The requirements specified in Para. 4.6.8 and 4.6.9 shall be met after the test.	Mate and unmate connectors for 100 cycles in the same method of testing as Specified in Para 4.6.8,4.6.9.
4.6.11	Resistance to Soldering Heat	No physical damage shall be evident after the test.	Subject product mounted on printed circuit boards to solder bath at 260±5°C for 3 seconds
<b>Environmental Requirements</b>			
4.6.12	Thermal Shock	The requirement specified in Para. 4.6.2 shall be met after the test.	Subject mated/Unmated connectors to 5 cycles between -55°C and +85°C MIL-STD-202, Method 107 Condition A
4.6.13	Humidity-Temperature Cycling	The requirement specified in Para. 4.6.2 shall be met after the test.	Subject mated connectors to 10 cycles of humidity-temperature changes between 25°C and 65°C at 95 % R.H.  MIL-STD-202, Method 106 with cold shock as -10°C
4.6.14	Temperature Life	The requirement specified in Para. 4.6.2 shall be met after the test.	Subject mated connectors to temperature life; 85±2°C, 250 Hours, MIL-STD-202, Method 108 Condition B
4.6.15	SO2 Gas	The requirement specified in Para. 4.6.2 shall be met after the test.	Engage connectors, and expose to SO2 on following conditions. SO2 Concentration: 10±3 ppm Relative Humidity: 90% min. Temperature : Room temperature Time : 48 hours

Fig.5 (end)

<b>tyco</b> <i>Electronics</i>	Tyco Electronics AMP Shanghai Ltd	PAGE	NO	REV	LOC
		7	108-60036	O	ES

### 3.7 Product Qualification and Requalification Tests.

Test of Examination	Test Group (a)								
	1	2	3	4	5	6(c)	7	8	9
Examination of Product	1,7	1,5	1,5	1,5	1,5	1,6	1,7	1,3	1,3
Termination Resistance, Dry Circuit	4,6	2,4	2,4	2,4	2,4	2,5			
Dielectric Withstanding Voltage							3,6		
Insulation Resistance							2,5		
Temperature Rise vs. Current								2	
Vibration						3			
Physical Shock						4			
Mating Force	2								
Unmating Force	3								
Durability	5								
Resistance to Soldering Heat									2
Thermal Shock (per Product Spec)			3						
Humidity-Temperature Cycling		3					4		
SO2 Gas					3				
Temperature Life				3					

- (a) See Para 4.1.A.
- (b) Numbers indicate sequence in which tests are performed.
- (c) Discontinuities shall not take place in this test group. During tests.

Fig. 6

<b>tyco</b> Electronics	Tyco Electronics AMP Shanghai Ltd	PAGE 8	NO 108-60036	REV O	LOC ES
----------------------------	--------------------------------------	-----------	-----------------	----------	-----------



## 5. QUALITY ASSURANCE PROVISIONS

### 5.1 Test Conditions:

All the tests shall be performed under any combination of the following test conditions.

Temperature : 15~35°C  
Relative Humidity : 45-75%  
Atmospheric Pressure : 86.7~106.7kPa

### 5.2 The test specimens to be employed for the tests, shall be conforming to the applicable product drawing(s).

Fig. 7 shows the low-level termination resistance and temperature rising measuring points. This drawing applies to horizontal type to horizontal type combination. But horizontal type to vertical type and vertical type to vertical type configurations shall also have their termination resistance measured between tines after installation on circuit boards.

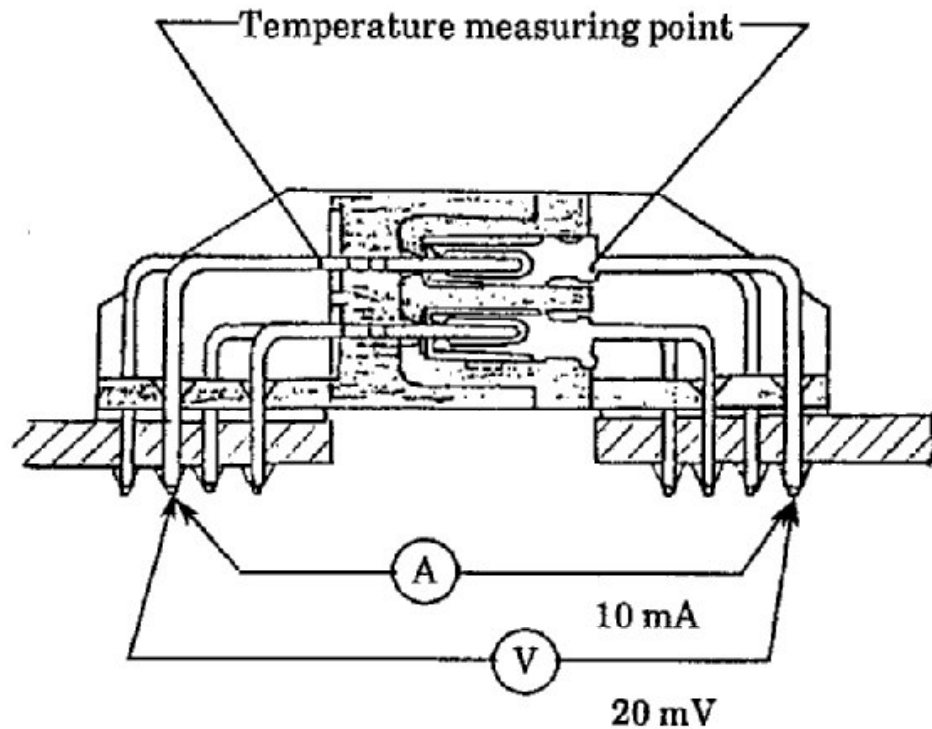

Fig. 7