

DESCRIPTION	SHELL PLATING: TIN OVER NI	SHELL PLATING: NI
REC. HEADER, 9 POS., STUD WITH THREAD M3	4-1740194-2	4-1740194-5
REC. HEADER, 9 POS., BRACKET WITH THREAD M3	2-1740194-2	2-1740194-5
REC. HEADER, 9 POS., STUD WITH THREAD UNC 4/40	3-1740194-2	3-1740194-5
REC. HEADER, 9 POS., BRACKET WITH THREAD UNC 4-40	1-1740194-2	1-1740194-5
REC. HEADER, 9 POS., BRACKET WITH HOLE Ø3.1	0-1740194-2	0-1740194-5

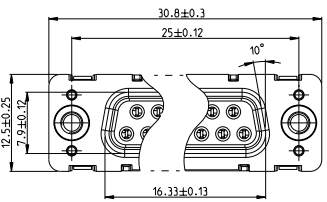
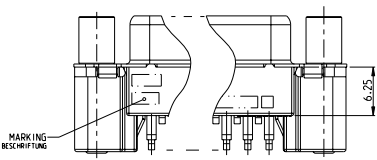
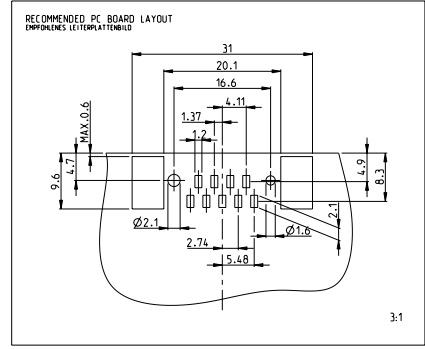
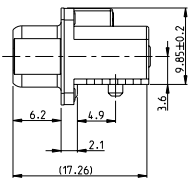
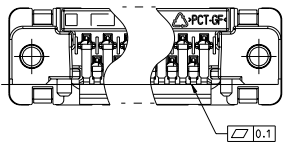

REMARKS:
 △ CONTACT AREA: MIN. 0.8µm Au OVER 1.27µm Ni.
 △ SOLDER AREA: 3-5µm Sn OVER MIN. 1.27µm Ni.
 2 PACKAGING SEE SHEET 2
 3 CONNECTOR SUITABLE FOR LEAD-FREE SMT SOLDER PROCESS
 △ TIN OVER NICKEL

BEMERKUNGEN:
 △ KONTAKTBEREICH: MIN. 0.8µm Au UEBER 1.27µm Ni.
 △ LOETBEREICH: 3-5µm Sn UEBER MIN. 1.27µm Ni.
 2 VERPACKUNGSART SIEHE BLATT 2
 3 STECKER GEEIGNET FUER BLEIFREIES SMT LOETEN
 △ ZINN UEBER NICKEL

POS.	QTY.	DESCRIPTION	REMARKING	SURFACE COATING	MATERIAL
2	1	THREAD STUD	GEW. UNTERSCHIEDLICH	NICKEL	STEEL
5	1	REC. CONTACT, SHD., LONG	BUCHSENKONTAKT, SHD., LANG	△	CuMg
4	1	REC. CONTACT, SHD., SHORT	BUCHSENKONTAKT, SHD., KURZ	△	CuMg
3	1	BRACKET, SHD., LEFT/RIGHT	BUCHSENKONTAKT, SHD., LINKS/RECHTS	△	CAST METAL
2	1	REC. HOUSING	BUCHSENKONTAKT, SHD., LANG	BLACK	PCT-GF
1	1	SHELL	BUCHSENKONTAKT, SHD., LANG	SEE TABLE	STEEL
				SEE TABLE	STEEL

THIS DRAWING IS A CONTROLLED DOCUMENT. DATE OF ISSUE: 09/07/2004. DRAWING NO.: 000779. REV: A. CUSTOMER DRAWING.

TE Connectivity
 HDP20 REC. HEADER, SMT, 9POS.
 HDP20 BUCHSENSTECCKER, SMT, 9POL.
 EUROSTYLE

SCALE: 1:1. SHEET: 1 OF 1. DATE: 09/07/2004. DRAWING NO.: 000779. REV: A. CUSTOMER DRAWING.

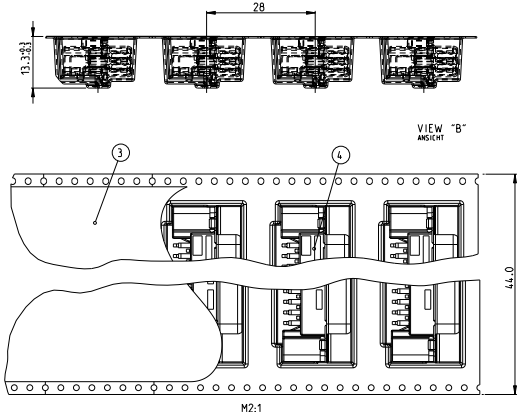
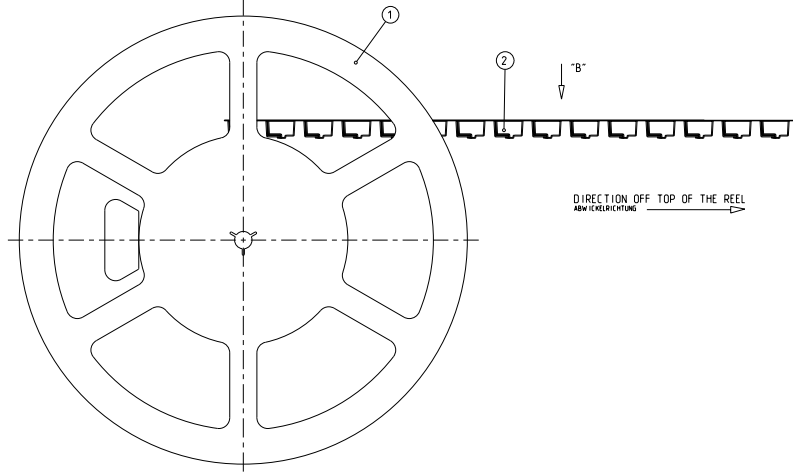
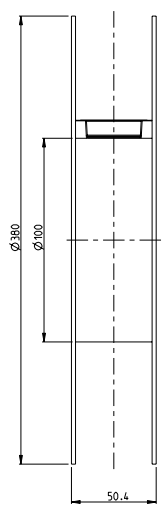

- REMARKS:**
- COVER TAPE WITH BLISTER BELT WELDED OR PASTED
 - BLISTER BELT, COVER AND TAPE ACC. TO DIN/IEC 286 PART 3
 - FIRST AND LAST RUNNING OF THE CARRIER TAPE ACC. TO DIN/IEC 286 PART 3
 - 7m BLISTERBELT AND 7.1m COVER TAPE. 225 LOOSE PIECE PARTS

- BEMERKUNGEN:**
- ABDECKBAND MIT BLISTERGURT VERSCHWEISST ODER VERKLEBT
 - BLISTERGURT, ABDECKBAND UND REEL NACH DIN/IEC 286 TEIL 3
 - VOR- UND NACHLAUF AM BLISTERGURT NACH DIN/IEC 286 TEIL 3
 - 7m BLISTERGURT UND 7.1m ABDECKBAND, 225 EINZELTEILE

QTY	REF	DESCRIPTION	UNIT	REMARKS	SURFACE	MATERIAL
4	225	SUB-D REC. HEADER, 9 POS., STUD M3				
4	-	SUB-D REC. HEADER, 9 POS., STUD UNC4-40				
4	-	SUB-D REC. HEADER, 9 POS., M3				
4	-	SUB-D REC. HEADER, 9 POS., UNC4-40				
4	-	SUB-D REC. HEADER, 9 POS.				
3	7.1m	LOOSE BELT FOR BLISTER BELT			TRANSPARENT	PET
2	7m	BLISTER BELT			GREY/BLACK	PS
1	1	REEL-PACKING			GREY	PS

ORDER NO.	POS.	DESCRIPTION	SURFACE	MATERIAL
1740194				

THIS DRAWING IS A CONTROLLED DOCUMENT.		DATE: 2007/2008	REV: 0001
DESIGNED BY: [Signature]	CHECKED BY: [Signature]	DATE: 2008/01/01	REV: 0001
DATE: 2008/01/01	SCALE: 1:1	PROJECT NO: 00779	REV: 0001
DATE: 2008/01/01	SCALE: 1:1	PROJECT NO: 00779	REV: 0001

TE Connectivity		HDP20 REC. HEADER, SMT, 9POS.	
HDP20 BUCHSENSTÜCKER, SMT, 9POL.		EUROSTYLE	
STATE	SCALE	DATE	REV
A	1:1	2008/01/01	0001