

4

3

2

1

THIS DRAWING IS UNPUBLISHED. RELEASED FOR PUBLICATION
 © COPYRIGHT - By - ALL RIGHTS RESERVED.

LOC		DIBT		REVISIONS			
P	LTR	DESCRIPTION	DATE	BY	APPD		
GP	00						
	Z1	REVISED PER ECO-11-004835	11MAR11	RK	HMR		

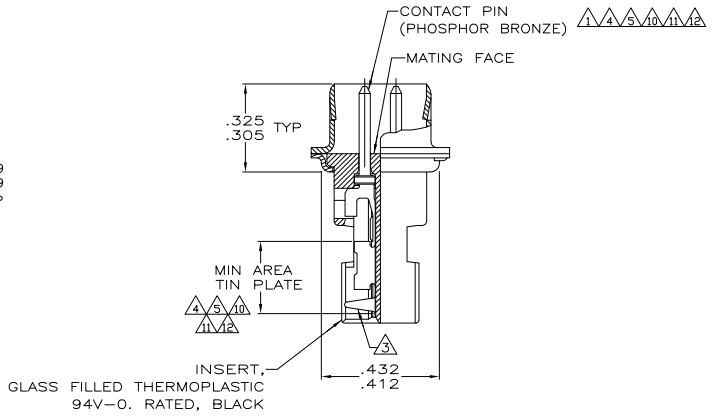
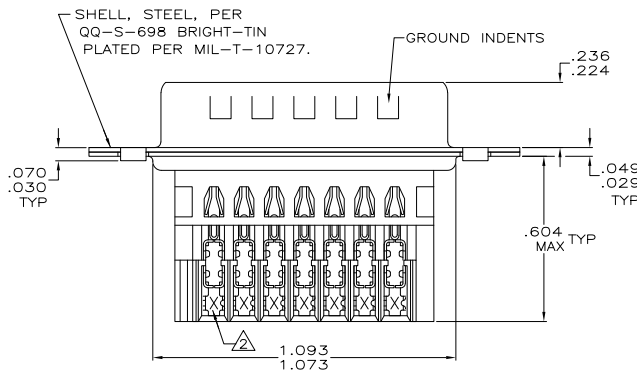
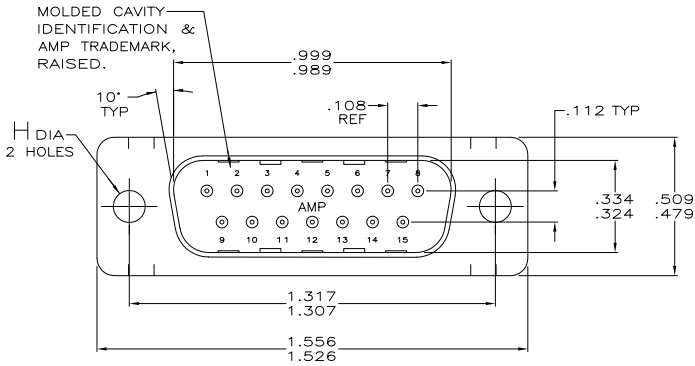

THIS DRAWING IS A CONTROLLED DOCUMENT.		DWG: L VARELA - DOCKS 11-18-04 OK: J GERACE 11-18-04 APP: M. WALMSLEY 11-18-04 PRODUCT SPEC: 108-40011 APPLICATION SPEC: 114-40002 WEIGHT: -	TE TE Connectivity PLUG ASSEMBLY, METAL SHELL, SIZE 2, 15 POSITION, SERIES HDE-20 FOR MASS TERMINATION	SIZE: CAGE CODE (FARROW 10) A200779C=745494 RESTRICTED TO: -
DIMENSIONS: INCHES 0 PLC ± .010 1 PLC ± .008 2 PLC ± .005 3 PLC ± .005 4 PLC ± .005 ANGLES ± .2°	FINISH: SEE TABLES	MATERIAL: SEE CALL OUT	CUSTOMER DRAWING	SCALE: 4:1 SHEET: 1 of 2 REV: Z1

1471-9 (3/11)

745494

4

3

2

1

THIS DRAWING IS UNPUBLISHED. RELEASED FOR PUBLICATION
 © COPYRIGHT - By - ALL RIGHTS RESERVED.

LOC	DIST	REVISIONS					
GP	00	P	LTR	DESCRIPTION	DATE	BY	APPD
-	-	-	-	SEE SHEET 1	-	-	-

- △ HOUSING FULLY LOADED WITH CONTACTS.
- △ NUMBER ON CONTACT INDICATES WIRE RANGE.
- △ CONTACT INSULATION RANGE: .060 MAXIMUM O.D.
- △ CONTACTS GOLD PLATED FOR A LENGTH OF .150 MIN FROM MATING END, .000030 MIN GOLD IN MATED AREA, .000100-.000200 BRIGHT TIN OR BRIGHT TIN-LEAD IN AREA SHOWN, ALL OVER .000050 MIN NICKEL UNDERPLATE ON ENTIRE CONTACT.
OR
CONTACTS GOLD PLATED FOR A LENGTH OF .150 MIN FROM MATING END, GOLD FLASH OVER .000030 MIN PALLADIUM-NICKEL IN MATED AREA, .000100-.000200 BRIGHT TIN OR BRIGHT TIN-LEAD IN AREA SHOWN, ALL OVER .000050 MIN NICKEL UNDERPLATE ON ENTIRE CONTACT.
- △ GOLD PLATED FOR LENGTH OF .150 MIN FROM MATING END, GOLD FLASH IN MATED AREA, .000100-.000200 BRIGHT TIN OR BRIGHT IN TIN-LEAD AREA SHOWN. .000030 NICKEL UNDERPLATE ON ENTIRE CONTACT.
- △ OBSOLETE PART NUMBER.
- △ GOLD PLATED FOR LENGTH OF .150 MIN FROM MATING END, .000050 MIN GOLD IN MATED AREA, .000100-.000200 BRIGHT TIN OR BRIGHT IN TIN-LEAD AREA SHOWN. .000050 NICKEL UNDERPLATE ON ENTIRE CONTACT.
- △ SUPERSEDED BY 745494-5.
- △ CONTACTS GOLD PLATED FOR A LENGTH OF .150 MIN FROM MATING END, .000030 MIN GOLD IN MATED AREA, .000100-.000200 MATTE TIN IN AREA SHOWN, ALL OVER .000050 MIN NICKEL UNDERPLATE ON ENTIRE CONTACT.
OR
CONTACTS GOLD PLATED FOR A LENGTH OF .150 MIN FROM MATING END, GOLD FLASH OVER PALLADIUM-NICKEL, .000030 MIN TOTAL IN MATED AREA, .000100-.000200 MATTE TIN IN AREA SHOWN, ALL OVER .000050 MIN NICKEL UNDERPLATE ON ENTIRE CONTACT.
- △ CONTACTS PLATED GOLD FLASH FOR A LENGTH OF .150 MIN FROM MATING END, .000100-.000200 MATTE TIN IN AREA SHOWN, ALL OVER .000030 MIN NICKEL UNDERPLATE ON ENTIRE CONTACT.
- △ CONTACTS GOLD PLATED FOR A LENGTH OF .150 MIN FROM MATING END, .000050 MIN GOLD IN MATED AREA, .000100-.000200 MATTE TIN IN AREA SHOWN, ALL OVER .000050 MIN NICKEL UNDERPLATE ON ENTIRE CONTACT.
OR
CONTACTS GOLD PLATED FOR A LENGTH OF .150 MIN FROM MATING END, GOLD FLASH OVER PALLADIUM-NICKEL, .000050 MIN TOTAL IN MATED AREA, .000100-.000200 MATTE TIN IN AREA SHOWN, ALL OVER .000050 MIN NICKEL UNDERPLATE ON ENTIRE CONTACT.

STANDARD	.156 .146	△12	2	#22-26	△1-745494-9
STANDARD	.125 .115	△12	2	#22-26	1-745494-8
STANDARD	.125 .115	△10	1	#26-30	1-745494-7
STANDARD	.125 .115	△11	2	#22-26	1-745494-6
STANDARD	.125 .115	△10	2	#22-26	1-745494-5
STANDARD	.125 .115	△	2	#22-26	△1-745494-4
SMALL PACK	.125 .115	△5	2	#22-26	△1-745494-3
STANDARD	.156 .146	△	2	#22-26	△1-745494-2
		△5	1	#26-30	△1-745494-0
STANDARD	.156 .146	△4	3	#20-22	△745494-9
			2	#22-26	△745494-8
			1	#26-30	△745494-7
			3	#20-22	△745494-6
STANDARD	.125 .115	△5	2	#22-26	△745494-5
			1	#26-30	△745494-4
STANDARD	.125 .115	△4	3	#20-22	△745494-3
			2	#22-26	△745494-2
			1	#26-30	△745494-1
PACKAGING	H	CONTACT FINISH	△2	AWG WIRE RANGE	PART NUMBER

THIS DRAWING IS A CONTROLLED DOCUMENT.

DIMENSIONS: INCHES 	DIMENSIONS: MILLIMETERS 	DATE: 11-18-04 BY: VABELA - DOCKS CHK: 11-18-04 APPR: GERACE NAME: M. WALMSLEY PRODUCT SPEC: 108-40011 APPLICATION SPEC: 114-40002 HEIGHT: -	DATE: 11-18-04 BY: VABELA - DOCKS CHK: 11-18-04 APPR: GERACE NAME: M. WALMSLEY PRODUCT SPEC: 108-40011 APPLICATION SPEC: 114-40002 HEIGHT: -	SIZE: A2 DATE CODE (DRAWING NO): 00779 ©: 745494	RESTRICTED TO: - SCALE: 4:1 SHEET: 2 of 2 REV: Z1
---------------------------	--------------------------------	---	---	--	--

CUSTOMER DRAWING

745494

A