

THE DRAWING IS UNPUBLISHED.
 RELEASED FOR PUBLICATION
 BY TYCO ELECTRONICS CORPORATION. ALL RIGHTS RESERVED.

LIC		DST		REVISIONS			
GP	00	TR	LTR	DESCRIPTION	DATE	DRN	APPD
		0		RELEASED PER EC 0513-0287-05	17NOV05	JG	SS
		01		REVISED PER ECO-10-000444	20JAN10	KK	HMR

CABLE SUPPLIED BY CUSTOMER
 Ø.480 MAX

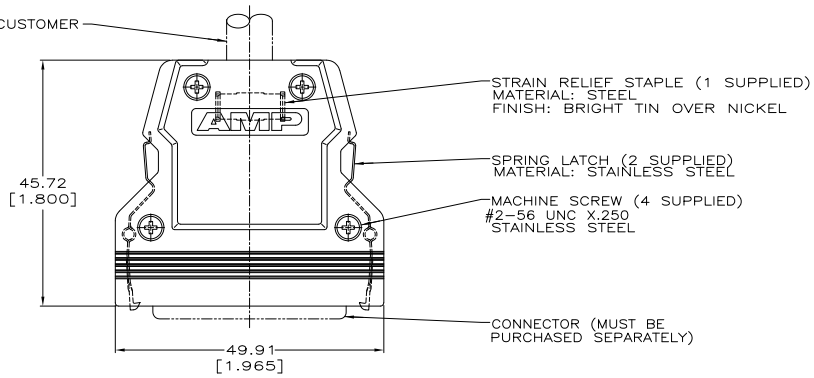

UPPER BACKSHELL (1 SUPPLIED)
 MATERIAL: ZINC
 FINISH: NICKEL OVER COPPER

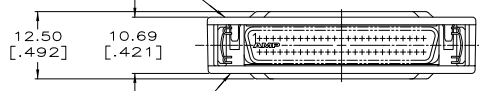

LOWER BACKSHELL (1 SUPPLIED)
 MATERIAL: ZINC
 FINISH: NICKEL OVER COPPER

- ⚠ PARTS PACKAGED AS A UNIT KIT.
- ⚠ PARTS INDIVIDUALLY BULK PACKAGED & SHIPPED AS A UNIT PACKAGE.
- ⚠ OBSOLETE PARTS: OBSOLETE CIS STREAMLINING PER D.RENAUD/D.SINISI

⚠ OBSOLETE	⚠	5749889-4
	⚠	5749889-3
PACKAGING		PART NO

**COPYRIGHT 2005
 TYCO ELECTRONICS CORP
 ALL RIGHTS RESERVED**

THIS DRAWING IS A CONTROLLED DOCUMENT.		DRN	17NOV05	Tyco Electronics Corporation Harrisburg, PA 17105-3608
DIMENSIONS: mm[INCHES]		DR	17NOV05	
TOLERANCES UNLESS OTHERWISE SPECIFIED:		APPD	17NOV05	NAME
Ø	PLC	▲	-	PRODUCT SPEC
1	PLC	▲	-	APPLICATION SPEC
2	PLC	▲	0.30 [015]	SIZE
3	PLC	▲	-	CAGE CODE
4	PLC	▲	-	DRAWING NO
ANGLES	▲	-	-	WEIGHT
MATERIAL	SEE CALLOUTS	FINISH	SEE CALLOUTS	RESTRICTED TO
CUSTOMER DRAWING		SCALE	2:1	SHEET 1 of 1
				REV 01

5749889

A