

4

3

2

1

THIS DRAWING IS UNPUBLISHED. RELEASED FOR PUBLICATION  
 © COPYRIGHT BY TYCO ELECTRONICS CORPORATION. ALL INTERNATIONAL RIGHTS RESERVED.

LOC	DIST	REVISIONS			
P	LTR	DESCRIPTION	DATE	MIN	APD
R		REV PER ECO-10-000179	27JAN10	PY	RL

- THIS PART CONFORMS TO REQUIREMENTS FOR DANIELS CRIMP TOOL NO. M300-BT, WITH DANIELS POSITIONER PART NO. SP689, STRIP LENGTH .375, #8 AWG SETTING 7, #10 AWG SETTING 3.
- MATES WITH 211161-1 IN AMPLIMITE CONNECTOR ASSEMBLIES ONLY.
- FINISH: PLATED GOLD .000050 [0.00127] MIN THK PER MIL-G-45204 OVER NICKEL .000050 [0.00127] MIN THK PER QQ-N-290.
- FINISH: PLATED GOLD .000030 [0.00076] MIN THK PER MIL-G-45204 OVER NICKEL .000050 [0.00127] MIN THK PER QQ-N-290.
- NOT FOR GENERAL DISTRIBUTION; USAGE RESTRICTED TO SPECIFIC CUSTOMER CONFIGURATION.

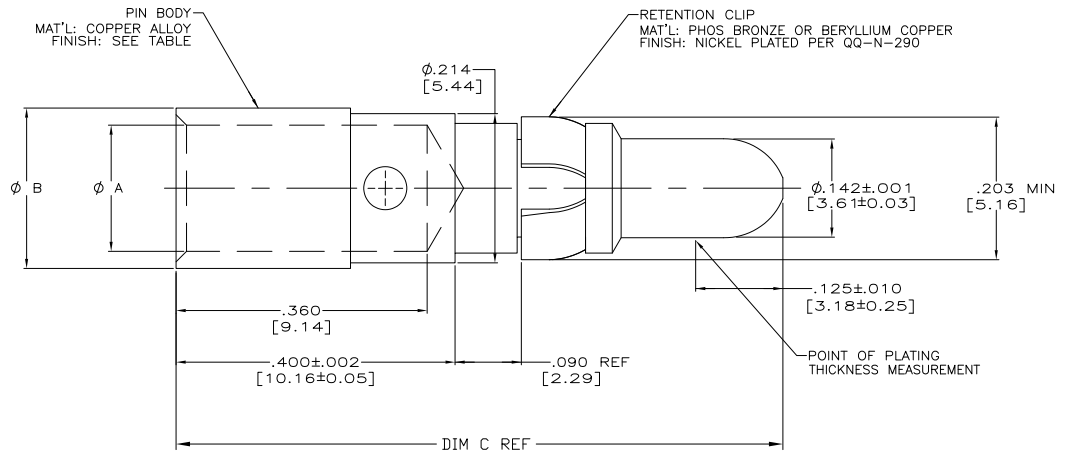

PRELIMINARY- NOT RELEASED FOR PRODUCTION	△	△	.948 [24.08]	.230 [5.84]	.181 [4.60]	#8 AWG	211159-5
PRELIMINARY- NOT RELEASED FOR PRODUCTION	△	△	.870 [22.10]	.185 [4.70]	.136 [3.45]	#10 AWG	211159-4
PRELIMINARY- NOT RELEASED FOR PRODUCTION	△	△	.870 [22.10]	.230 [5.84]	.181 [4.60]	#8 AWG	211159-3
	△	△	.870 [22.10]	.185 [4.70]	.136 [3.45]	#10 AWG	211159-2
	△	△	.870 [22.10]	.230 [5.84]	.181 [4.60]	#8 AWG	211159-1
REMARKS	FINISH	DIM C	DIM B	DIM A	WIRE SIZE	PART NUMBER	

THIS DRAWING IS A CONTROLLED DOCUMENT.		DR: C. THOMAS 11/10/00	Tyco Electronics Corporation Harrisburg, PA 17105-3608	
DIMENSIONS: INCHES [mm]		CHK: D. MILLER 11/10/00	Tyco Electronics	
TOLERANCES UNLESS OTHERWISE SPECIFIED:		APP: D. MILLER 11/10/00	ASSEMBLY, PIN CONTACT POWER VII, #8 & #10 AWG	
0 PLC ± .010 1 PLC ± .005 2 PLC ± .003 (0.13) 3 PLC ± .002 4 PLC ± .001 ANGLES ± .001		PRODUCT SPEC: 108-10045	SIZE: A2	CAGE CODE: 00779
MATERIAL: SEE CALLOUTS	FINISH: SEE TABLE	APPLICATION SPEC: 114-10014	DRAWING NO: C-211159	RESTRICTED TO: -
		RIGHT: -	SCALE: 10:1	SHEET: 1 of 1
		CUSTOMER DRAWING		REV: R

1471-9 (1/08)

211159

A