

4 3 2 1

THIS DRAWING IS UNCLASSIFIED  
 (C) COPYRIGHT IS BY AMP INCORPORATED. ALL RIGHTS RESERVED.

LOC	DIST	REVISIONS					
DF	D0	F	LIB	DESCRIPTION	DATE	ENR	APPD
		G		REV PER 063D-0520-00	7-03	CT	DM

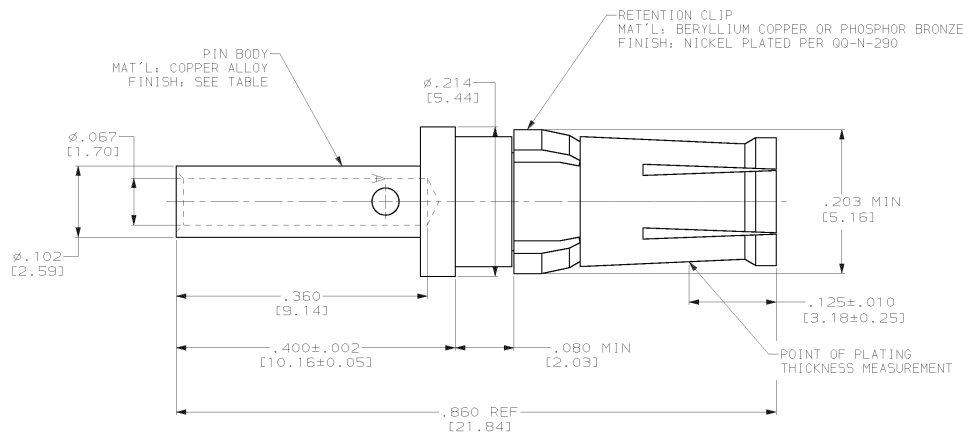

- THIS PART CONFORMS TO REQUIREMENTS FOR DANIELS CRIMP TOOL NO. FT8, WITH DANIELS POSITIONER PART NO. TP731, STRIP LENGTH .375, #16 AWG SETTING 8, #18 AWG SETTING 6.
- MATES WITH 212013-1 IN AMPLIMITE CONNECTOR ASSEMBLIES ONLY.
- FINISH: PLATED GOLD .000050 [0.00127] MIN THK PER MIL-G-45204 OVER NICKEL .000050 [0.00127] MIN THK PER 00-N-290.
- FINISH: PLATED GOLD .000030 [0.00076] MIN THK PER MIL-G-45204 OVER NICKEL .000050 [0.00127] MIN THK PER 00-N-290.
- WIRE BARREL WILL ACCEPT #16-#18 AWG WIRE.

PRELIMINARY NOT RELEASED FOR PRODUCTION		212014-2
		212014-1
FINISH		PART NUMBER
THIS DRAWING IS A CONTROLLED DOCUMENT DWG: C. C. THOMAS 11/10/00 CHK: D. MILLER 11/10/00 D. MILLER 11/10/00 DATE: 11/10/00 PRODUCT SPEC: 10B-10045 APPLICATION SPEC: 114-10014 HEIGHT: - SEE CALLOUTS SEE TABLE CUSTOMER DRAWINGS		
<b>AMP</b> AMP Incorporated Harrisburg, PA 17105-3608		<b>ASSEMBLY, SOCKET CONTACT</b> <b>POWER VIII, #16 &amp; #18 AWG</b>
SIZE: CASE CODE: DRAWING NO: A200779 SCALE: 10:1 SHEET 1 OF 1 REV 6		RESTRICTED TO: -