

4

3

2

1

THIS DRAWING IS UNPUBLISHED. RELEASED FOR PUBLICATION. ALL RIGHTS RESERVED.

LOC	DIST	REVISIONS					
DF	DO	P	LTR	DESCRIPTION	DATE	BY	APP'D
		J1		REVISED PER ECO-11-005030	11MAR11	RK	HMR

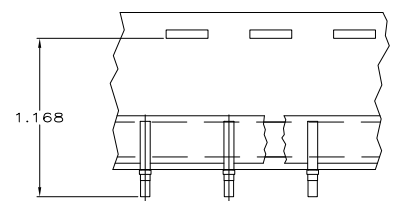
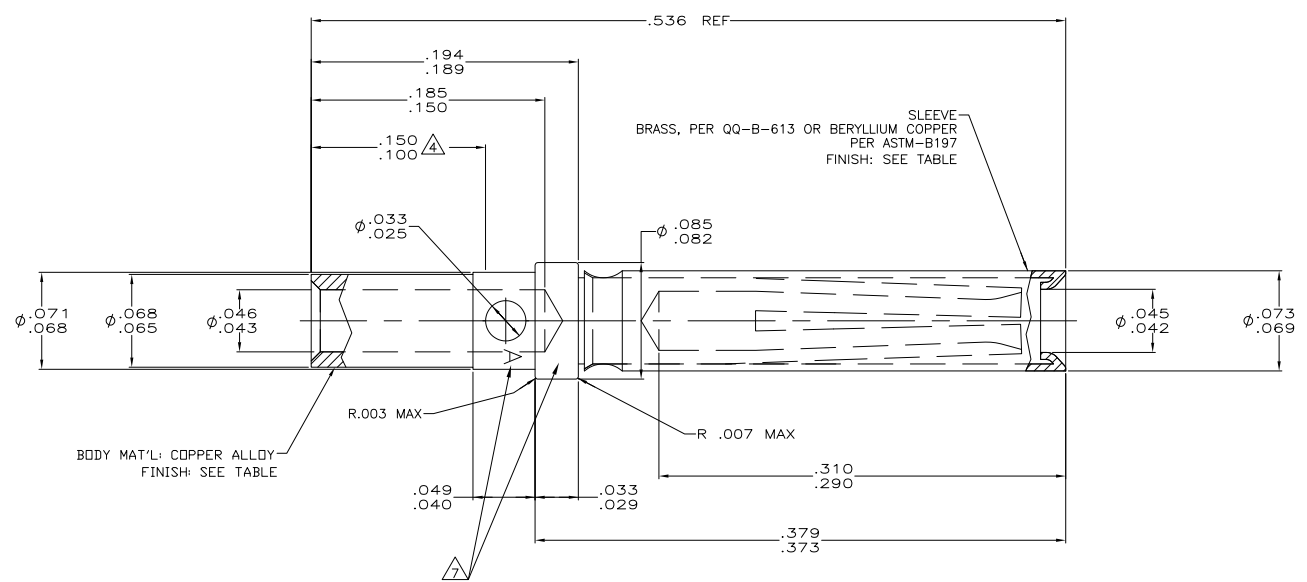

- CONTACTS MUST MEET ALL REQUIREMENTS OF GSFC-S-311-P-4/08 AND AS39029.
- ALL DIAMETERS ARE CONCENTRIC WITH EACH OTHER WITHIN .004 T.I.R.
- ALL SURFACES HAVE  $\sqrt{63}$  OR BETTER FINISH. POINT OF PLATING THICKNESS MEASUREMENT.
- SLEEVE MAY BE CRIMPED OR DIMPLED TO BODY.
- MINIMUM SEPERATION FORCE OF 7 OZ USING A .039 PIN AND 4 OZ MAX ENGAGEMENT FORCE USING A .041 PIN.
- OPTIONAL LOCATION FOR STAMPED LETTER 'A'
- PLATING: GOLD PER ASTM-B-488 (TYPE II) OVER COPPER PER MIL-C-14550, CLASS 4.
- PLATING: GOLD PER ASTM-B-488 (TYPE II) OVER NICKEL PER QQ-N-290.

	$\triangle 9$	AS SHOWN	206793-4
OBSOLETE	$\triangle 8$	SAME AS -1 EXCEPT $\triangle 6$	206793-3
	$\triangle 8$	SAME AS -1 EXCEPT TAPE MOUNTED 5,000 CONTACTS PER REEL	206793-2
	$\triangle 8$	AS SHOWN	206793-1
		FINISH	DESCRIPTION
			PART NO

THIS DRAWING IS A CONTROLLED DOCUMENT.		DRN	C. C. THOMAS	11-20-02		TE Connectivity		
DIMENSIONS: INCHES		CHK	D. MILLER	11-20-02		SOCKET CONTACT ASSY, SIZE 20, AMPLIMITE		
OTHER DIMENSIONS: MILLIMETERS		APP'D	D. MILLER	11-20-02	NAME			
MATERIAL: SEE CALLOUT		APPLICATION SPEC			SIZE	CAGE CODE	DRAWING NO	RESTRICTED TO
FINISH		HEIGHT			A2	00779	C-206793	
CUSTOMER DRAWING					SCALE	20:1	SHEET	1 of 1
					REV	J1		