Connector, CHAMP*, Blindmate, .050 Series I

1. SCOPE

1.1. Content

This specification covers performance, tests and quality requirements for the CHAMP* Blindmate .050 Series I straddle mount plug, vertical plug, and vertical receptacle connectors.

1.2. Qualification

When tests are performed on the subject product line, procedures specified in 109 Series Test Specifications shall be used. All inspections shall be performed using the applicable inspection plan and product drawing.

1.3. Qualification Test Results

Successful qualification testing on the subject product line was completed on 15Nov96. The test file number for this testing is CTL 7426-039-002. This documentation is on file at and available from the Americas Regional Laboratory.

2. APPLICABLE DOCUMENTS

The following documents form a part of this specification to the extent specified herein. Unless otherwise specified, the latest edition of the document applies. In the event of conflict between requirements of this specification and the product drawing, the product drawing shall take precedence. In the event of conflict between the requirements of this specification and the referenced documents, this specification shall take precedence.

2.1. TE Connectivity (TE) Documents

- 109-1: General Requirements for Test Specifications
- 109 Series: Test Specifications as indicated in Figure 1
- 114-6061: Application Specification
- 501-363: Qualification Test Report

2.2. Commercial Standard

EIA 700A0AE

3. REQUIREMENTS

3.1. Design and Construction

Product shall be of the design, construction and physical dimensions specified on the applicable product drawing.

3.2. Materials

- Contact: Phosphor bronze, gold plating on mating end, tin-lead plating on opposite end, all over nickel plating
- Housing: Polyester, black, UL94V-0
- Retention leg: Brass, tin-lead plating

3.3. Ratings

- Voltage: 100 volts AC
- Current: The maximum current at 30°C temperature rise shall not exceed values listed for specific contact positions energized as shown in Figure 1, reference EIA 700A0AE and Figures 5A and 5B.

Position Size	Current (A)	Voltage (V)	Contact Positions Voltage Applied (In Parallel)	Contact Positions Ground (In Parallel)
80	2	5	34, 35	75, 76
	3	12	2, 3, 4	41, 42, 43

NOTE Current levels are based on steady state conditions. When the connector is used in “hot plug” applications, current spikes shall be minimized using a current limiting device.

Figure 1

- Temperature: -55 to 105°C

3.4. Performance and Test Description

Product is designed to meet electrical, mechanical and environmental performance requirements specified in Figure 1. Unless otherwise specified, all tests shall be performed at ambient environmental conditions per Test Specification 109-1.

3.5. Test Requirements and Procedures Summary

Test Description	Requirement	Procedure
Examination of product.	Meets requirements of product drawing and Application Specification 114-6061.	Visual, dimensional and functional per applicable quality inspection plan.
ELECTRICAL		
Termination resistance.	ΔR 15 milliohms maximum.	TE Spec 109-6-1. Subject mated contacts assembled in housing to 50 mv maximum open circuit at 100 ma maximum. See Figure 4.
Insulation resistance.	1000 megohms minimum.	TE Spec 109-28-4. Test between adjacent contacts of mated samples.
Dielectric withstanding voltage.	300 vac at sea level.	TE Spec 109-29-1. Test between adjacent contacts of mated samples.
Temperature rise vs current.	See Para 3.3.B.	TE Spec 109-45-1. Changes made for compliance with EIA 700A0AE. See Figure 5.
MECHANICAL		
Solderability.	Solderable area shall have minimum of 95% solder coverage.	TE Spec 109-11-2. Subject samples to solderability.

Figure 2 (continued)

Test Description	Requirement	Procedure
Vibration, random.	No discontinuities of 1 microsecond or longer duration. See Note.	TE Spec 109-21-7. Subject mated samples to 3.13 G's rms. 1 hour in each of 3 mutually perpendicular planes. See Figure 6.
Physical shock.	No discontinuities of 1 microsecond or longer duration. See Note.	TE Spec 109-26-1. Subject mated samples to 30 G's half-sine shock pulses of 11 milliseconds duration. 3 shocks in each direction applied along 3 mutually perpendicular planes, 18 total shocks. See Figure 6.
Durability.	See Note.	TE Spec 109-27. Mate and unmate samples for 500 cycles at maximum rate of 600 cycles per hour.
Mating force.	110 grams maximum per contact.	TE Spec 109-42, Condition A. Measure force necessary to mate samples at maximum rate of .5 inch per minute.
Unmating force.	15 grams minimum per contact.	TE Spec 109-42, Condition A. Measure force necessary to unmate samples at maximum rate of .5 inch per minute.

ENVIRONMENTAL

Thermal shock.	See Note.	TE Spec 109-22. Subject mated samples to 5 cycles between -55 and 105°C.
Humidity-temperature cycling.	See Note.	TE Spec 109-23-3, Condition B. Subject mated samples to 10 cycles between 25 and 65°C at 95% RH.
Temperature life.	See Note.	TE Spec 109-43. Subject mated samples to temperature life at 105°C for 1000 hours.
Mixed flowing gas.	See Note.	TE Spec 109-85-2. Subject mated samples to environmental class II for 14 days.

NOTE

Shall meet visual requirements, show no physical damage and shall meet requirements of additional tests as specified in Test Sequence in Figure 3.

Figure 2 (end)

3.6. Product Qualification and Requalification Test Sequence

Test or Examination	Test Group (a)			
	1	2	3	4
	Test Sequence (b)			
Examination of product	1,9	1,8	1,8	1,3
Termination resistance	3,7	2,6		
Insulation resistance			2,6	
Dielectric withstanding voltage			3,7	
Temperature rise vs current		7		
Solderability				2
Vibration	5	5		
Physical shock	6			
Durability	4			
Mating force	2			
Unmating force	8			
Thermal shock			4	
Humidity-temperature cycling			5	
Temperature life		4		
Mixed flowing gas		3(c)		

NOTE

- (a) See paragraph 4.1.A.
 (b) Numbers indicate sequence in which tests are performed.
 (c) Precondition samples with 10 cycles durability.

Figure 3

4. QUALITY ASSURANCE PROVISIONS

4.1. Qualification Testing

A. Sample Selection

Samples shall be prepared in accordance with applicable Instruction Sheets and shall be selected at random from current production. All test groups shall each consist of a minimum of 5 samples.

B. Test Sequence

Qualification inspection shall be verified by testing samples as specified in Figure 3.

4.2. Requalification Testing

If changes significantly affecting form, fit or function are made to product or manufacturing process, product assurance shall coordinate requalification testing, consisting of all or part of original testing sequence as determined by development/product, quality and reliability engineering.

4.3. Acceptance

Acceptance is based on verification that product meets requirements of Figure 2. Failures attributed to equipment, test setup or operator deficiencies shall not disqualify product. When product failure occurs, corrective action shall be taken and samples resubmitted for qualification. Testing to confirm corrective action is required before resubmittal.

4.4. Quality Conformance Inspection

The applicable quality inspection plan will specify sampling acceptable quality level to be used. Dimensional and functional requirements shall be in accordance with applicable product drawing and this specification.

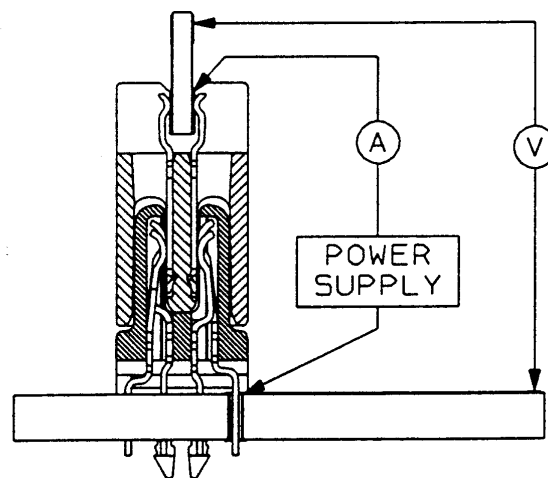

Figure 4
Termination Resistance Measurement Points

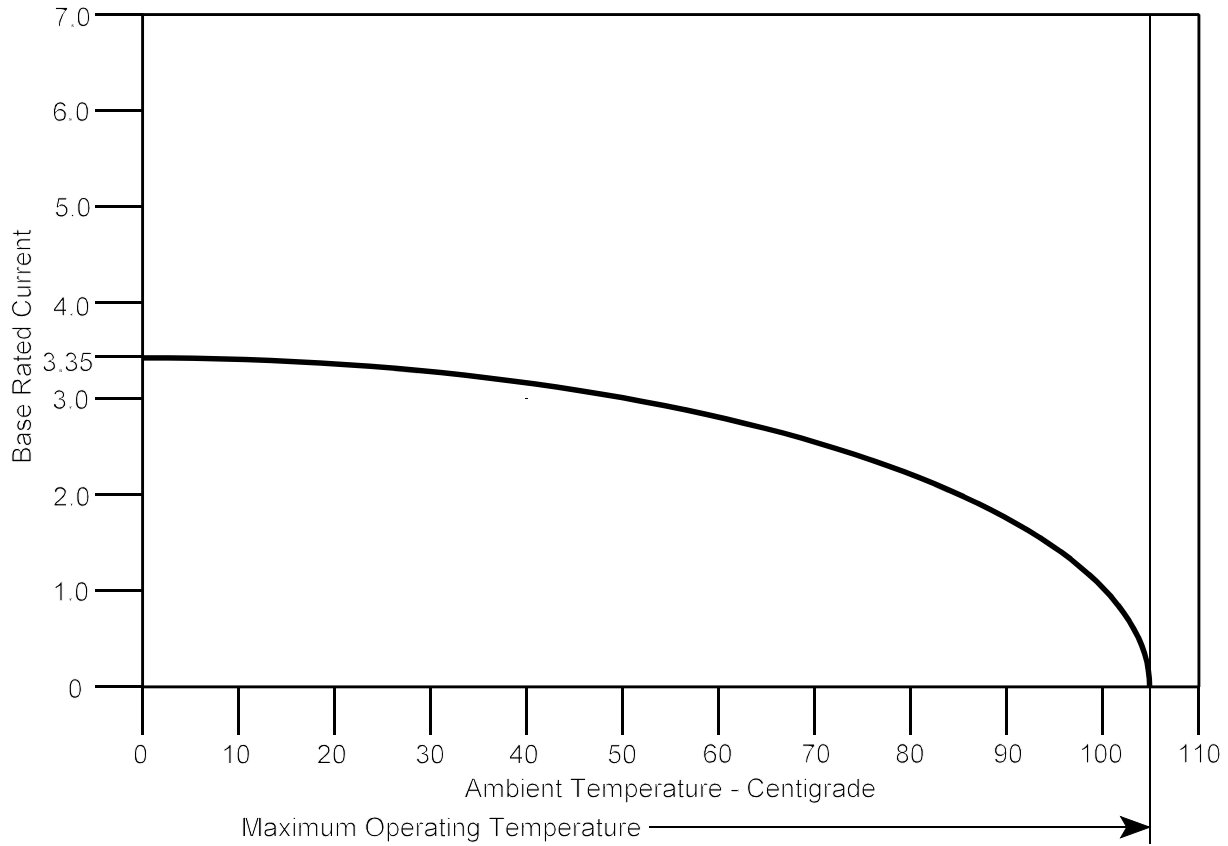

Figure 5A
Current Carrying Capability

Connector Loading	Loading Factor
1 Contact	1
2 Contacts Parallel	.89
3 Contacts Parallel	.59

NOTE

To determine acceptable current carrying capacity for percentage connector loading and wire gage indicated, use the Multiplication Factor (F) from the above chart and multiply it times the Base rated Current for a single circuit at maximum ambient operating temperature as shown in Figure 5A.

Figure 5B
Current Rating

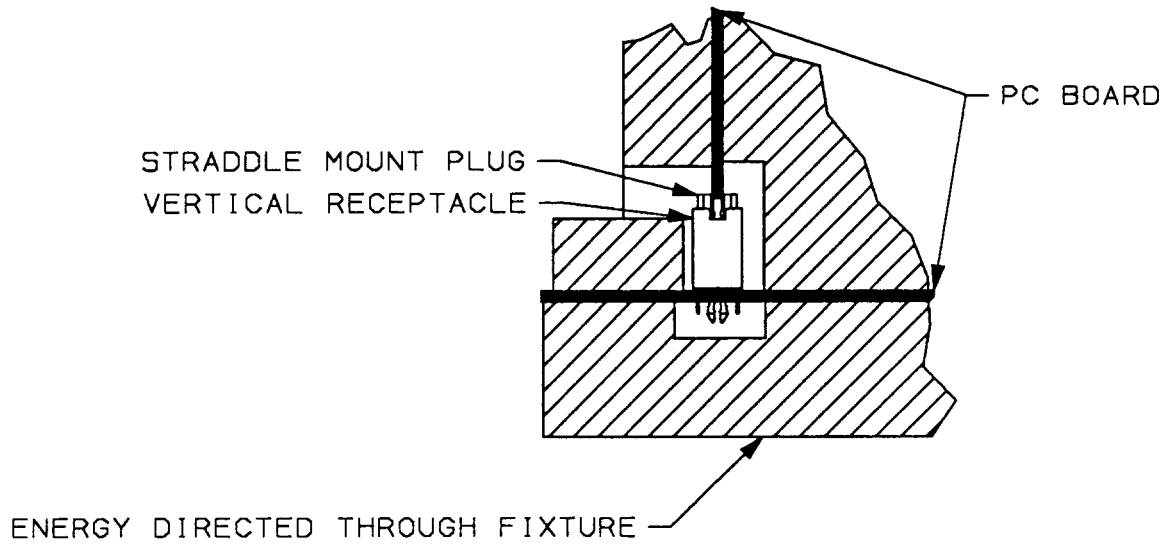
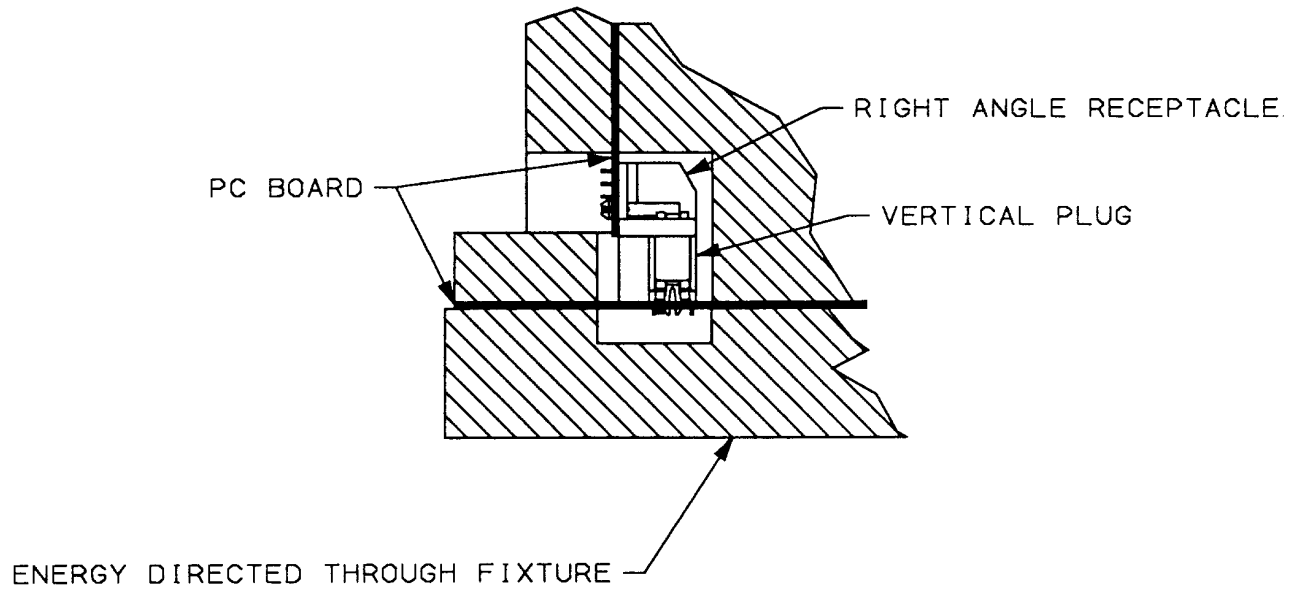

Figure 6
Vibration & Physical Shock Mounting Fixtures