

THIS DRAWING IS UNCLASSIFIED  
DATE 06-08-2001 BY 60322 UCBAW/SJS  
ALL RIGHTS RESERVED. "TODOS LOS DERECHOS RESERVADOS"  
© COPYRIGHT 1996 BY AMP INCORPORATED. LOS DERECHOS DE ESTA DIBUJACIÓN SON PATENTES, MARCAS O PENDIENTES

| LOC | DIST | REV | DATE            | BY      | APP    |
|-----|------|-----|-----------------|---------|--------|
| AL  | 2    | A   | EC ES00-0007-97 | OGMAT97 | RSA JS |

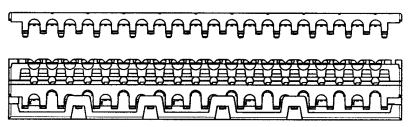

PACKAGING, 1 BOX WITH 10 BAGS  
EACH BAG CONTAINS:  
1 BAG WITH 10 UNITS ITEM 1  
1 BAG WITH 10 UNITS ITEM 2 OR 3

STANDARD LABELING

EMBALAJE, 1 CAJA CON 10 BOLSAS  
CADA BOLSA CONTIENE:  
1 BOLSA CON 10 UNIDADES ITEM 1  
1 BOLSA CON 10 UNIDADES ITEM 2 o 3

ETIQUETADO ESTANDAR

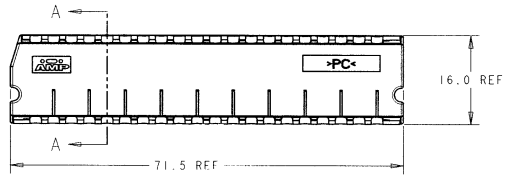

SCALE 2:1

- CUT-OFF BLADE (STAINLESS STEEL)  
CUCHILLA DE CORTE (ACERO INOXIDABLE)
- UPPER BODY (POLYCARBONATE IVORY COLORED)  
CUERPO SUPERIOR (POLICARBONATO COLOREADO MARFIL)
- PLUGGABLE LOWER BODY (POLYCARBONATE BLUE COLORED)  
CUERPO INFERIOR ENCHUFABLE (POLICARBONATO COLOREADO AZUL)
- PLUGGABLE CONTACT (PHOSPHOR BRONZE. FINISH: TIN PLATED)  
CONTACTO DERIVACION (BRONCE FOSFOROSO. ACABADO: ESTAÑADO)
- PROTECTOR (POLYCARBONATE RED COLORED)  
PROTECTOR (POLICARBONATO COLOREADO ROJO)

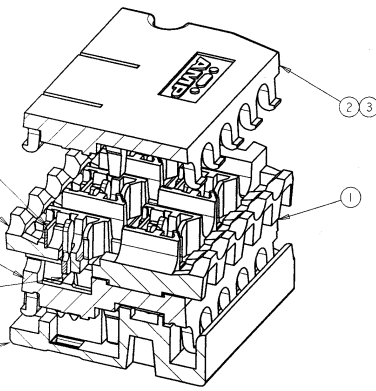

PERSPECTIVE OF SECTION A-A (BEFORE CRIMPING)  
SCALE 5:1

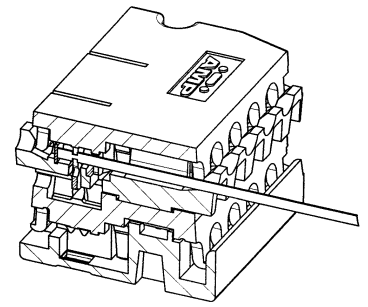

PERSPECTIVE OF SECTION A-A (AFTER CRIMPING)  
SCALE 5:1

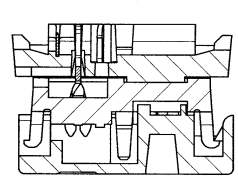
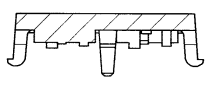

SECTION A-A (BEFORE CRIMPING)  
SCALE 5:1

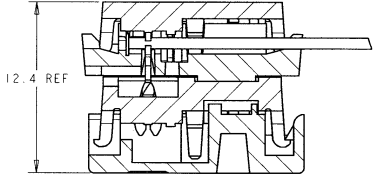

SECTION A-A (AFTER CRIMPING)  
SCALE 5:1

| QTY PER KIT | DESCRIPTION   | MATERIAL                       | COLOR                       | ITEM |
|-------------|---|--------------------------------|-----------------------------|------|
| 1           | COVER, 10 PAIRS, AMP STACK MARK IV<br>TAPA, 10 PARES, AMP STACK MARK IV                                 | POLYCARBONATE<br>POLICARBONATO | TRANSPARENT<br>TRANSPARENTE | 3    |
| 1           | COVER, 10 PAIRS, AMP STACK MARK IV<br>TAPA, 10 PARES, AMP STACK MARK IV                                 | POLYCARBONATE<br>POLICARBONATO | IVORY<br>MARFIL             | 2    |
| 1           | PLUGGABLE BODY ASSY, 10 PAIRS, AMP STACK MARK IV<br>CJTO CUERPO ENCHUFABLE, 10 PARES, AMP STACK MARK IV | SEE DETAIL<br>VER DETALLE      | SEE DETAIL<br>VER DETALLE   | 1    |
| 1           | DESCRIPTION   | MATERIAL                       | COLOR                       | ITEM |

|   |  |                                      |  |  |                                    |   |  |               |                 |
|---|--|--------------------------------------|--|--|------------------------------------|---|--|---------------|-----------------|
| DIMENSIONES<br>TÍTUL<br>                            | TOLERANCIAS Y FINESSES<br>TOLERANCIAS<br>0. P.A.C. ALUM. ±0.10<br>1. P.A.C. ALUM. ±0.1<br>2. P.A.C. ALUM. ±0.1<br>3. P.A.C. ALUM. ±0.1<br>4. P.A.C. ALUM. ±0.1<br>5. P.A.C. ALUM. ±0.1<br>6. P.A.C. ALUM. ±0.1 | MATERIAL<br>P.A.C. ALUM.<br>ALUMINIO | PRODUCT SPEC.<br>ESPEC. DE PRODUCTO<br>108-22075 | APPLICATION SPEC.<br>ESPEC. DE APLICACION<br>114-22001 | WEIGHT<br>PESO<br>-                | AMP / OROUS<br>GATNAL<br>31-Jan-96<br>SANABRIA<br>12-May-97<br>AMP / AMPUS<br>16-Feb-96<br>SANABRIA | NAME<br>TÍTULO<br><b>AMP</b><br>AMP Espanola S.A.<br>Barcelona, Spain. |               |                 |
| PLUG CONNECTOR KIT, 10 PAIRS,<br>AMP STACK™ MARK IV |  |                                      | SIZE<br>TAMAÑO<br>A2                             | CASE CODE<br>CÓDIGO<br>00779                           | DRAWING NO.<br>PLANO NO.<br>737859 | SCALE<br>ESCALA<br>1:1  | SHEET<br>HOJA<br>1   | OF<br>DE<br>1 | REV<br>REV<br>A |