

LOC	DIST	REVISIONS					
FH	00	P	LTR REV	DESCRIPTION MODIFICATIONS	DATE	DWN DESS.	APVD APPR
			c	MISE A JOUR PLAN/CARTOUCHE	24-Jun-08	FM	GP

MARKING: REFERENCE, DIE, , DATE

DIE: E140

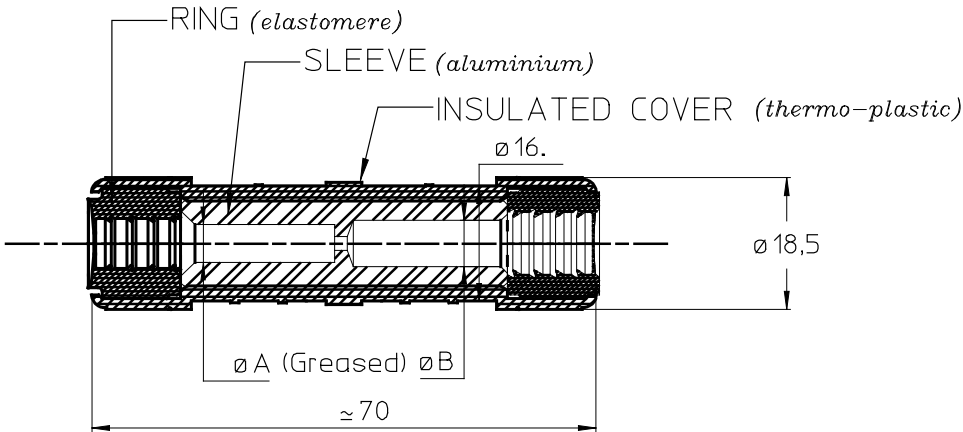

Number of crimps: 2x3 (width=5mm) or 2x2 (width=9mm)

CONDUCTORS		Part Number	REFERENCE	Dimensions (mm)	
cond.A mm2	cond.B mm2			ø A	ø B
04	04	709348-1	MJPB 04	2,7	2,7
	06	709348-3	MJPB 04-06		3,3
	10	709348-2	MJPB 04-10		4,3
	16	709348-4	MJPB 04-16		5,3
06	06	709348-5	MJPB 06	3,3	3,3
	10	709348-6	MJPB 06-10		4,3
	16	709348-8	MJPB 06-16		5,3
	25	1-709348-0	MJPB 06-25		6,5
	35	1-709348-2	MJPB 06-35		8,0
10	10	3-709348-1	MJPB 10	4,3	4,3
	16	1-709348-4	MJPB 10-16		5,3
	25	1-709348-6	MJPB 10-25		6,5
	35	1-709348-8	MJPB 10-35		8,0
	50	-	MJPB 10-50		8,8
16	16	2-709348-0	MJPB 16	5,3	5,3
	25	2-709348-2	* MJPB 16-25		6,5
	35	2-709348-5	MJPB 16-35		8,0
	50	2-709348-6	MJPB 16-50		8,8
25	25	2-709348-8	MJPB 25	6,5	6,5
	35	3-709348-2	MJPB 25-35		8,0
	50	3-709348-7	MJPB 25-50		8,8
35	35	3-709348-5	MJPB 35	8,0	8,0
	50	-	MJPB 35-50		8,8
50	50	-	MJPB 50	8,8	8,8

RING COLOR CODE:

- 04: ivory
- 06: brown
- 10: green
- 16: blue
- 25: orange
- 35: red
- 50: yellow

RELEASED FOR PUBLICATION
 ALL RIGHTS RESERVED.
 TOUS DROITS RESERVES
 BY TYCO ELECTRONICS CORPORATION
 THIS DRAWING IS UNPUBLISHED.
 DIFFUSION RESTREINTE
 © COPYRIGHT 2007

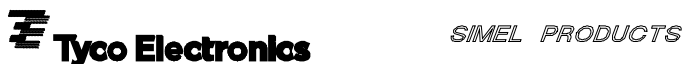
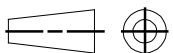
DIMENSIONS: mm	DWN /DESSINE F.MOIROUD 24-Jun-08	MATERIAL MATIERE	FINISH FINITION
TOLERANCES UNLESS OTHERWISE SPECIFIED PER TOLERANCES NON SPECIFIEES SELON :	CHK /VERIFIE L.MAINIER		
	APVD /APPROUVE G.PORCHERAY		
	PRODUCT SPEC SPEC. PRODUIT	NAME TITRE MJPB	
APPLICATION SPEC SPEC. APPLICATION	SIZE FORMAT A4	CAGE CODE 00779	DRAWING NO No PLAN ©=709348
APPROX. WEIGHT MASSE APPROX.	UNIQUEMENT POUR REFERENCE		RESTRICTED TO RESERVE A
	CUSTOMER DWG / PLAN CLIENT	SCALE ECHELLE 1:1	SHEET FEUILLE 1 OF 1 DE 1