

THIS DRAWING IS UNAPPROVED
 UNLESS OTHERWISE NOTED
 ALL RIGHTS RESERVED

REV	DATE	DESCRIPTION	BY	APP
CM 00		REVISED PER EDD-11-016326	180CT11	KH SM

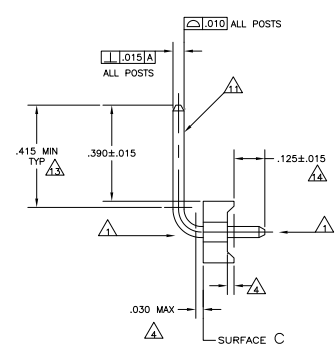

- △ POST TO WITHSTAND 13 NEWTONS (3LBS.) MIN. AXIAL FORCE IN BOTH DIRECTIONS SHOWN WITHOUT DISLODGING.
- △ TOLERANCES APPLY TO SOLDER SIDE OF BOARD.
- △ MEASURED AT SURFACE [-C]
- △ PLASTIC FLASH PERMITTED IN THIS AREA.
- 5. PARTS COMPLY WITH AMP SOLDERABILITY SPEC. NO. 109-11-2.
- △ ONE HOLE MAY BE UNDERSIZED (.065/.060 DIA.) FOR ASSEMBLY RETENTION DURING WAVE SOLDERING.
- △ MATERIAL: HEADER-THERMOPLASTIC POLYESTER NON-FILLED 94V-0(NATURAL) POST-COPPER ALLOY (SEE NOTES 13 & 14 FOR PLATING)
- △ COORDINATE DIMENSION APPLIES FROM CENTER OF ACTUAL FEATURE.
- 9. PLASTIC BURRS CAUSED BY CUT-OFF TOOLING ARE PERMITTED WITHIN THE MAXIMUM TOLERANCE ENVELOPE.
- △ POST TO BE MEASURED WHEN STRIP IS HELD FLAT.
- △ POST MUST WITHSTAND TWO 90° BENDS AGAINST EXTRUSION WITHOUT BREAKING.
- △ DIMENSION SHOULD BE .140-.430 WHEN MATING WITH A MTA 156 CONNECTOR ASSEMBLY, .140 MIN WHEN MATING WITH A SL 156 WIRE-TO-BOARD CONNECTOR ASSEMBLY OR .140-.475 WHEN MATING WITH A SL 156 BOARD-TO-BOARD CONNECTOR ASSEMBLY.
- △ PLATING: GOLD PLATE AREA .000030 GOLD OR .00003 MIN GOLD FLASH OVER .00027 PALLADIUM NICKEL, PER TE CONNECTIVITY'S DISCRETION, ALL SIDES, OVER NICKEL UNDERPLATE, .000050 MIN, ALL SIDES AND ENTIRE LENGTH OF POST.
- △ BRIGHT TIN/LEAD (93/7) PLATE AREA .000150-.000350 THICK, ALL FOUR SIDES, .175 MIN, FOR -2 THRU -24, MATTE TIN PLATE AREA .000150-.000350 THICK, ALL FOUR SIDES, .175 MIN FOR -32 THRU -54
- △ OBSOLETE PARTS: OBSOLETE CIS STREAMLING PER D.RENAUD/D.SINIS

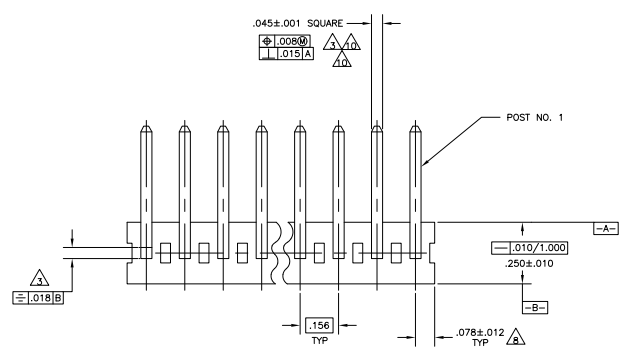
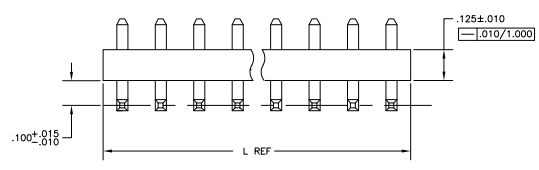
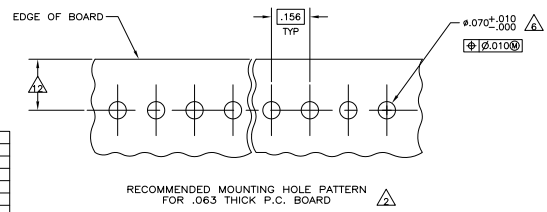

	MM	IN	MM	IN
.063	1.60	-	-	-
.080	1.52	-	-	-
.045	1.14	1.000	25.40	-
.030	0.76	.475	12.07	-
.018	0.46	.430	10.92	-
.015	0.38	.415	10.54	-
.012	0.30	.390	9.91	-
.010	0.25	.250	6.35	-
.008	0.20	.156	3.96	-
.005	0.13	.140	3.56	-
.001	0.03	.125	3.18	-
.000350	0.0089	1.00	2.54	-
.000150	0.0038	1.078	1.98	-
.000050	0.00127	0.70	1.78	-
.000015	0.00038	.065	1.65	-
IN	MM	IN	MM	

RECOMMENDED MOUNTING HOLE PATTERN FOR .063 THICK P.C. BOARD

FINISH	IN	MM	NUMBER OF POSITIONS	PART NUMBER	FINISH	IN	MM	NUMBER OF POSITIONS	PART NUMBER	
△ SUPERCEDED BY 5-641204-4	TIN	3.744	95.10	24	5-641204-4	TIN-LEAD	3.744	95.10	24	2-641204-4
△ SUPERCEDED BY 5-641204-3	TIN	3.588	91.14	23	5-641204-3	TIN-LEAD	3.588	91.14	23	2-641204-3
△ SUPERCEDED BY 5-641204-2	TIN	3.432	87.17	22	5-641204-2	TIN-LEAD	3.432	87.17	22	2-641204-2
△ SUPERCEDED BY 5-641204-1	TIN	3.276	83.21	21	5-641204-1	TIN-LEAD	3.276	83.21	21	2-641204-1
△ SUPERCEDED BY 5-641204-0	TIN	3.120	79.25	20	5-641204-0	TIN-LEAD	3.120	79.25	20	2-641204-0
△ SUPERCEDED BY 4-641204-9	TIN	2.964	75.29	19	4-641204-9	TIN-LEAD	2.964	75.29	19	1-641204-9
△ SUPERCEDED BY 4-641204-8	TIN	2.808	71.32	18	4-641204-8	TIN-LEAD	2.808	71.32	18	1-641204-8
△ SUPERCEDED BY 4-641204-7	TIN	2.652	67.36	17	4-641204-7	TIN-LEAD	2.652	67.36	17	1-641204-7
△ SUPERCEDED BY 4-641204-6	TIN	2.496	63.40	16	4-641204-6	TIN-LEAD	2.496	63.40	16	1-641204-6
△ SUPERCEDED BY 4-641204-5	TIN	2.340	59.44	15	4-641204-5	TIN-LEAD	2.340	59.44	15	1-641204-5
△ SUPERCEDED BY 4-641204-4	TIN	2.184	55.47	14	4-641204-4	TIN-LEAD	2.184	55.47	14	1-641204-4
△ SUPERCEDED BY 4-641204-3	TIN	2.028	51.51	13	4-641204-3	TIN-LEAD	2.028	51.51	13	1-641204-3
△ SUPERCEDED BY 4-641204-2	TIN	1.872	47.55	12	4-641204-2	TIN-LEAD	1.872	47.55	12	1-641204-2
△ SUPERCEDED BY 4-641204-1	TIN	1.716	43.59	11	4-641204-1	TIN-LEAD	1.716	43.59	11	1-641204-1
△ SUPERCEDED BY 4-641204-0	TIN	1.560	39.62	10	4-641204-0	TIN-LEAD	1.560	39.62	10	1-641204-0
△ SUPERCEDED BY 3-641204-9	TIN	1.404	35.66	9	3-641204-9	TIN-LEAD	1.404	35.66	9	1-641204-9
△ SUPERCEDED BY 3-641204-8	TIN	1.248	31.70	8	3-641204-8	TIN-LEAD	1.248	31.70	8	1-641204-8
△ SUPERCEDED BY 3-641204-7	TIN	1.092	27.74	7	3-641204-7	TIN-LEAD	1.092	27.74	7	1-641204-7
△ SUPERCEDED BY 3-641204-6	TIN	.936	23.77	6	3-641204-6	TIN-LEAD	.936	23.77	6	1-641204-6
△ SUPERCEDED BY 3-641204-5	TIN	.780	19.81	5	3-641204-5	TIN-LEAD	.780	19.81	5	1-641204-5
△ SUPERCEDED BY 3-641204-4	TIN	.624	15.85	4	3-641204-4	TIN-LEAD	.624	15.85	4	1-641204-4
△ SUPERCEDED BY 3-641204-3	TIN	.468	11.89	3	3-641204-3	TIN-LEAD	.468	11.89	3	1-641204-3
△ SUPERCEDED BY 3-641204-2	TIN	.312	7.92	2	3-641204-2	TIN-LEAD	.312	7.92	2	1-641204-2
△ SUPERCEDED BY 3-641204-1	TIN	.156	3.96	1	3-641204-1	TIN-LEAD	.156	3.96	1	1-641204-1

THIS DRAWING IS A CONTROLLED DOCUMENT. THE ORIGINAL IS KEPT IN THE DRAWING OFFICE.

TE Connectivity
 MTA-156 HEADER ASSEMBLY, PLAIN, RIGHT ANGLE, .045 SQUARE POST, .000030 GOLD

DATE: 01/07/79
 DRAWING NO: 641204

CUSTOMER DRAWING

